

# KCSE MOCKS

SET 1

## CROSS COUNTRY TRIALS

### ALL SUBJECTS

**Dear Candidates, Attempt these Joint Mocks!**

**For Marking Schemes Call 0705525657**

NAME..... INDEX NO.....

443/1

CANDIDATE'S

SIGNATURE.....

### MATHEMATICS

#### Paper 1

**2½ Hours**

Paper1 **section 1**(50marks)

1. Points S(-2,2) and T(-3,7) are mapped onto S<sup>1</sup>(4,-10) and T<sup>1</sup>(0,10) by an enlargement .  
Calculate the enlargement scale factor.  
(3marks)

2. Given that  $\frac{1}{2x} = (0.732)^3 + \sqrt[3]{85.3}$  , use mathematical tables to find the value of x in standard form correct to 3 significant figures  
(3marks)

3. Simplify  $\frac{12x^2 + ax - 6a^2}{9x^2 - 4a^2}$   
(3 marks)

4. All prime numbers less than ten are arranged in ascending order to form a number.

(a) Write down the number formed (1  
mark)

(b) Express the number in (a) above in expanded form (2  
marks)

5. A two digit number is such that the one's digit is four more than the tens digit, and the sum of the digits is 14. Find the number  
(3 marks)

6 Paul bought a refrigerator on hire purchase by paying monthly instalments of Ksh. 2000 per month for 40 months and a deposit of Ksh. 12,000. If this amounted to an increase of 25% of the original cost of the refrigerator, what was the cash price of the refrigerator?  
(3 marks)

7. Find all the integral values of x which satisfy the inequality (3 marks)

$$3(1 + x) < 5x - 11 < x + 45$$

8. Without using calculator, evaluate

$$\left( \frac{7}{3} \left[ \frac{2}{5} \text{ of } 1\frac{2}{3} - \frac{1}{2} \left( \frac{1\frac{2}{3} - 2\frac{1}{2}}{\frac{1}{3} - \frac{19}{27}} \right)^{\frac{1}{2}} + \frac{2}{3} \right] \right)^{\frac{1}{2}}$$
 leaving the answer as a mixed fraction.(4 marks)

9. During a certain month, the exchange rates in a bank were as follows;

	buying (Ksh.)	selling (Ksh.)
--	------------------	-------------------

US \$	1.65	1.80
Euro	03.75	03.93

A tourist left Kenya to the United States with Ksh.1 000,000. On the air port he exchanged all the money to dollars and spent 190 dollars on air ticket. While in US he spent 4500 dollars for upkeep and proceeded to Europe. While in Europe he spent a total of 2000 Euros. How many Euros did he remain with? (3marks)

10. A school decided to make a beautiful picnic site to be used by students and teachers as a resting point. The site was designed to be triangular in shape measuring 40 metres, 60 metres and 80 metres. Calculate the area of the picnic site. (Answer correct to 1 d.p)  
(3 marks)

11. A regular  $n$ -sided polygon has its interior angle equal to 4 times its exterior. Find  $n$ . (3 marks)

12. The ratio of the lengths of the corresponding sides of two similar rectangular petrol tanks is 3:5. The volume of the smaller tank is  $8:1\text{m}^3$ . Calculate the volume of the larger tank.  
(3 marks)
13. ABCD is a rhombus. A is the point (2, 1) and C is the point (4, 7). Find the equation of the diagonal BD in the form  $ax + by = c$ .  
(3marks)
14. A man walks directly from point A towards the foot of a tall building 240m away. After covering 180m, he observes that the angle of elevation of the top of the building is  $45^\circ$ . Determine the angle of elevation of the top of the building from A.  
(3 marks)

15. The G.C.D. and L.C.M. of three numbers are 3 and 1008 respectively. If two of the numbers are 48 and 72, find the least possible value of the third number.  
(3 marks)

16. An ant moved from X the midpoint of RS through P in the right pyramid below

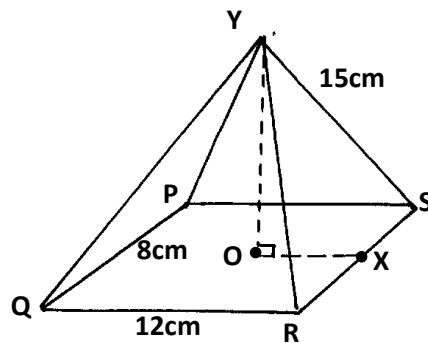

Draw the net of the pyramid showing the path of the ant hence find the distance it moved.  
(4marks)

**SECTION II (50 marks)**

***ANSWER ANY FIVE***

17. Three warships A,B and C are at sea such that ship B is 500km on a bearing N30E from ship A. Ship C is 700km from ship B on a bearing of  $120^\circ$ . An enemy ship D is sighted 800km due south of ship B.

a) Taking a scale of 1cm to represent 100km, locate the positions of ships A, B, C and D. (4 marks)

b) Find the bearing of:

i) Ship A from D (1 mark)

ii) Ship D from C (1 mark)

c) Use scale drawing to determine the distance between

i) D and A (1 mark)

ii) C and D. (1 mark)



d) Measure angle DAC and angle BCD (2 marks)

18. a) A rectangular tank of base 2.4m by 2.8m and a height of 3m contains 3600litres of water initially. Water flows into the tank at the rate of 0.5litres per second. Calculate:

i) The amount needed to fill the tank (2marks)

ii) The time in hours and minutes required to fill (3marks)

b). Pipe A can fill an empty tank in 3hours while pipe B can fill the same tank in 6hours .When the tank is full, it can be emptied by pipe C in 8hours .Pipes A and B are opened at the same time when the tank is empty .If one hour later pipe C is also opened, find the total time taken to fill the tank.

(5marks)

19. A solid is made up of a conical frustum and a hemispherical top. The slant height of the frustum is 8cm and its base radius is 4.2cm. If the radius of the hemispherical top is 3.5cm

a) Find the area of:

i) the circular base. (2 marks)

ii) the curved surface of the frustum (3 marks)

iii) the hemispherical surface

(3marks)

b) A similar solid has a total surface area of  $81.51\text{cm}^2$ . Determine the radius of its base.  
(2marks)

19. In the figure below, O is the center of the circle. PQ is a tangent to the circle at N. Angle NCD is  $10^\circ$  and angle ANP is  $30^\circ$

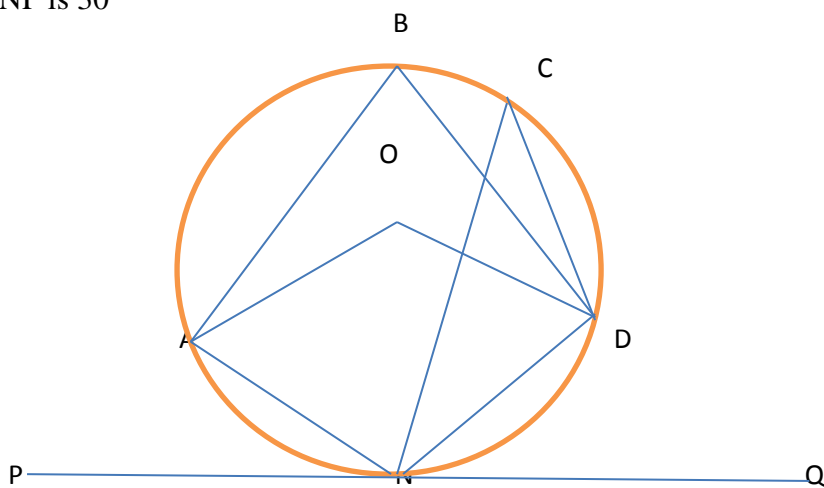

Giving reasons find;

- a. Angle DON  
(2marks)

b. Angle DNQ  
(2marks)

c. Angle DBA  
(2marks)

d. Angle ONA  
(2marks)

e. Angle ODN.  
(2marks)

20. Two quantities P and Q are connected by the equation  $P = KQ^n$ . The table below gives the values of P and Q

--	--	--	--	--	--	--

a) State the linear equation connecting P and Q  
(1 mark)

b) Using a scale of 1cm to represent 0.1 units in both axes, draw a suitable straight line graph on the grid provided

(5 marks)

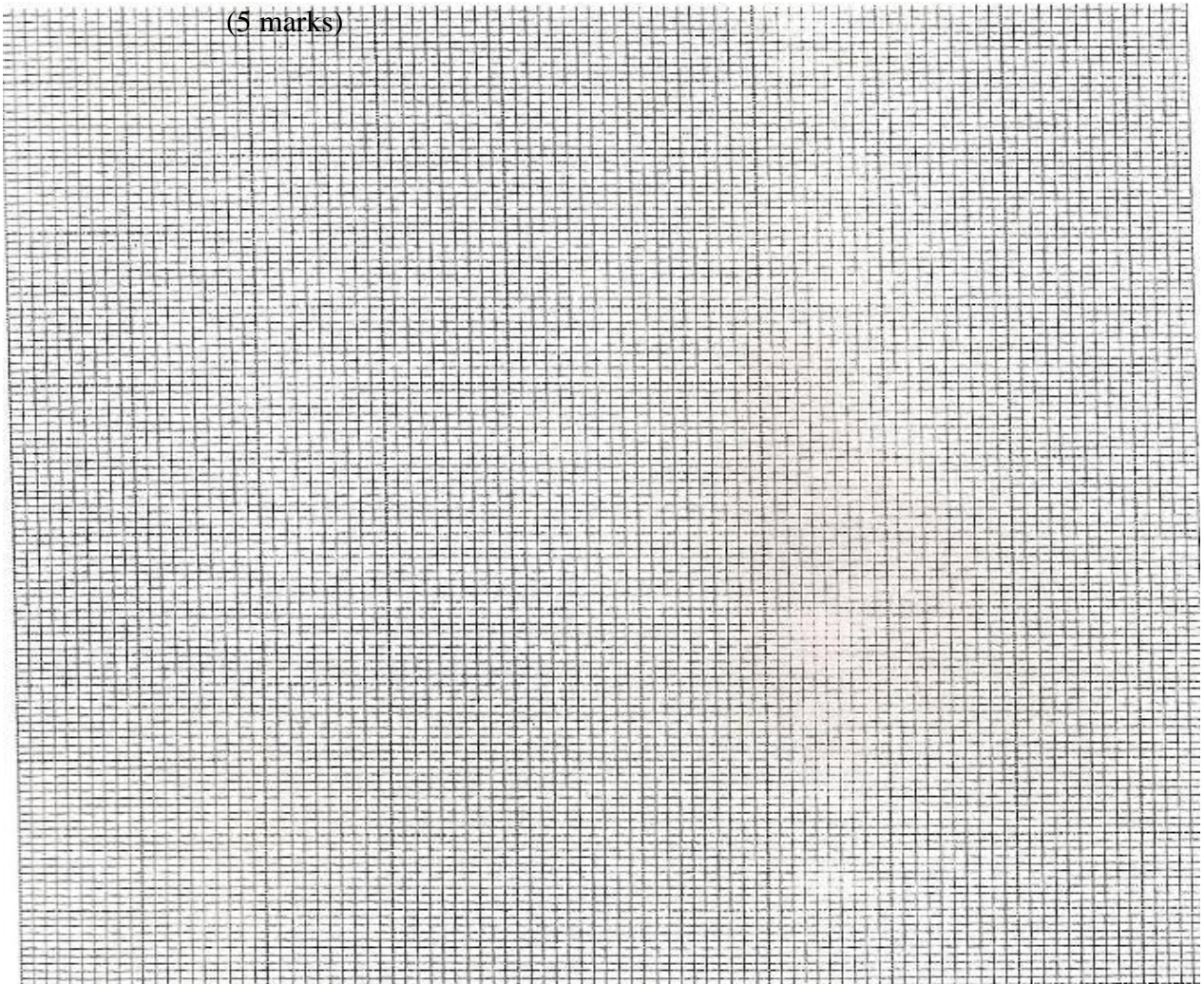

c) Use your graph in b) above to determine the approximate values of **K** and **n**.  
(2 marks)

- d) From the graph, find the value of Q when P=3  
(2 marks)

22. The displacement  $h$  metres of a particle moving along a straight line after  $t$  seconds is given by  $h = -2t^3 + \frac{3}{2}t^2 + 3t$ .

- a) Find its initial acceleration (3 marks)

- b) Calculate;  
i) The time when the object was momentarily at rest (3 marks)

- ii) Its displacement by the time it comes to rest (2 marks)

- c) Calculate the maximum speed attained (2 marks)

23.a) Complete the table below for graphs of  $y=\sin x$  and  $y=2\sin(x+30)$

(2 marks)

		0	0	0	20
in x			.87		
sin (x +30)		.5		.74	

e) Using a suitable scale on the grid below draw the graphs of  $y = \sin x$  and  $y = 2\sin (x +30)$  for  $0 \leq x \leq 360^\circ$   
(4 marks)

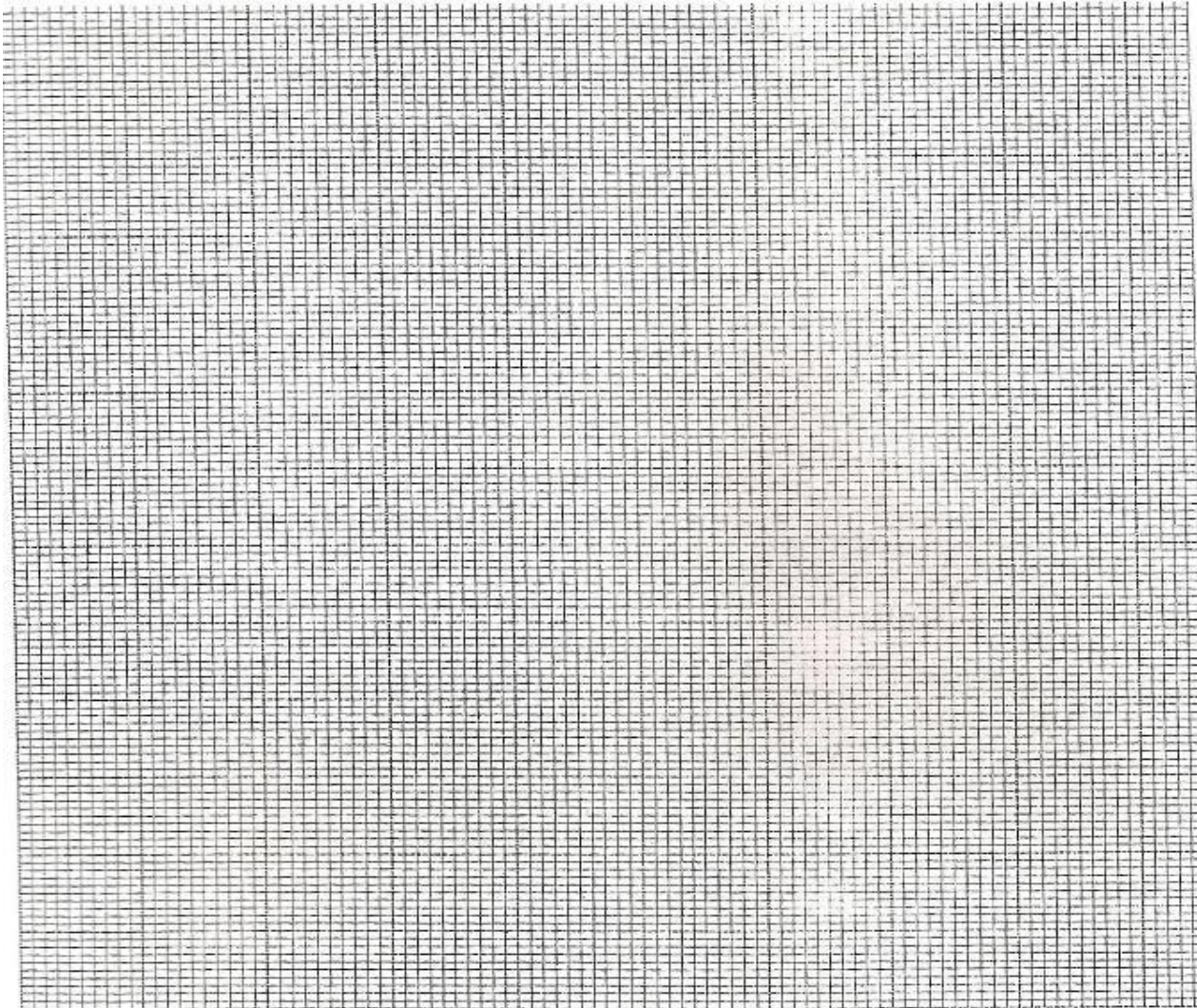

c) State the transformations that would map  $y = \sin x$  onto  $y = 2\sin(x+30)$ . (2 mark)

d) Find the values of  $x$  which satisfy the equation  $\sin x - 2\sin(x+30) = 0$ . (2 marks)

24. A trailer moving at a speed of 80km/h is being overtaken by a car moving at 100km/h in a clear section of a road. Given that the bus is 21m long and the car is 4m long.

a) How much time (in seconds) will elapse before the car can completely overtake the bus? (3 marks)



- b) How much distance (in metres) will the car travel before it can completely overtake the bus?  
(2 marks)
- c) Given that as soon as the car completed overtaking the trailer, a bus heading towards the trailer and the car and moving at a speed of 90km/h became visible to the car driver. It took exactly 18 seconds for the car and the bus to completely by pass each other from the moment they first saw each other.
- i. How far was the tail of the bus from the tail of the car at the instance they first saw each other given that the bus is 12 metres long?  
(3 marks)
  - ii. How far a part was the trailer and the bus just immediately after the car and the bus had passed each other?  
(2 marks)

**MATHEMATICS**  
**PAPER 2**  
**TIME: 2 ½ HOURS**

**SECTION I (50 MARKS)**

1. Evaluate without using Mathematical tables or a calculator. (3mks)

$$2\log 5 - \frac{1}{2}\log 6 + 2\log 40$$

2. Solve for x given that the following is a singular matrix

(2mks)

$$\begin{pmatrix} 1 & 2 \\ x & x-3 \end{pmatrix}$$

3. Make d the subject of the formula.

(3mks)

$$a^2 = \sqrt{\frac{1+d^2}{b^2} - \frac{b}{3}}$$

4. Simplify  $\frac{3}{\sqrt{7-2}} + \frac{1}{\sqrt{7}}$  leaving your answer in the form  $a + b\sqrt{c}$ , where a, b and c are rational numbers.  
(3mks)
5. Calculate the percentage error in the volume of a cone whose radius is 9.0cm and slant length 15.0cm.  
(3mks)
6. A quantity A is partly constant and partly varies inversely as a quantity B. Given that A = -10 when B = 2.5 and A = 10 when B = 1.25, find the value of A when B = 1.5. (4mks)

7. The table below shows corresponding values of  $x$  and  $y$  for a certain curve.

y	1.0	1.2	1.4	1.6	1.8	2.0	2.2
x	6.5	6.2	5.2	4.3	4.0	2.6	2.4

Using 3 strips and mid-ordinate rule, estimate the area between the curve  $x$  axis, the line  $x = 1$  and  $x = 2.2$ .

(2mks)

8. 14 people can build 10 huts in 30 days. Find the number of people working at the same rate that will build 18 similar huts in 27 days.

(3mks)

9. The coordinates of two airports M and N are  $(60^{\circ}\text{N}, 35^{\circ}\text{W})$  and  $(60^{\circ}\text{N}, 15^{\circ}\text{E})$  respectively.

Calculate;

- (i) The longitude difference.

(1mk)

- (ii) the shortest time an aeroplane whose speed is 250 knots will take to fly from M to N along a circle of latitude.

(2mks)

10. (a) Expand  $(x - 0.2)^5$  in ascending powers of  $x$ . (2mks)

- (b) Use your expansion up to the fourth term to evaluate  $9.8^5$ .

(2mks)

11. The figure below is a cuboid ABCDEFGH.  $AB = 12\text{cm}$ ,  $BC = 5\text{cm}$  and  $CF = 6.5\text{cm}$ .

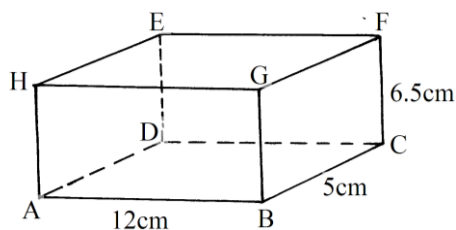

- (a) State the projection of AF on the plane ABCD.

(1mk)

(b) Calculate the angle between AF and the plane ABCD correct to 2 decimal places.

(3mks)

12. Show that  $\frac{\sin x(\cos x + 1)}{\cos x} = \sin x + \tan x$ .

(3mks)

13. The mid-point of AB is (1,-1.5, 2) and the position vector of a point A is  $-1\mathbf{i} + j$ . Find the magnitude of  $\vec{AB}$  where O is the origin.

(3mks)

14. Draw a line of best fit for the graph of y against x using the values in the table below. Hence determine the equation connecting y and x.

x	0.4	1.0	1.4	2.0	2.5
y	0.5	1.0	1.2	1.5	2.0

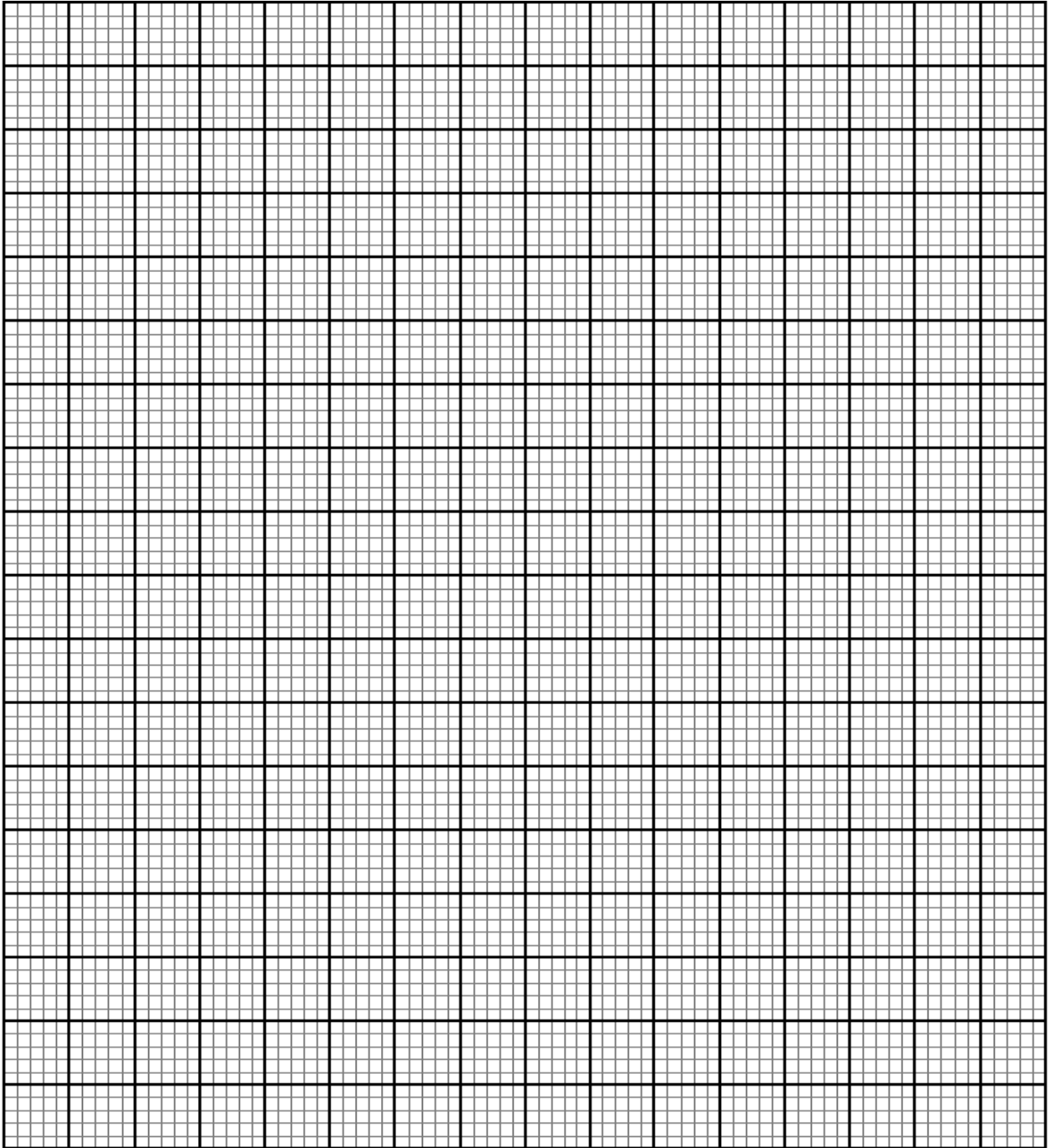

15. A coffee dealer mixes two brands of coffee, x and y to obtain 40kg of the mixture worth Ksh. 2,600. If brand x is valued at Ksh. 70 per kg and brand y is valued at Ksh. 55 per kg. Calculate the ratio in its simplest form in which brands x and y are mixed.  
(4mks)

16. The figure below shows a circle centre O. AB and PQ are chords intersecting externally at a point C.  $AB = 9\text{cm}$ ,  $PQ = 5\text{cm}$  and  $QC = 4\text{cm}$ . Find the length of BC.  
(3mks)

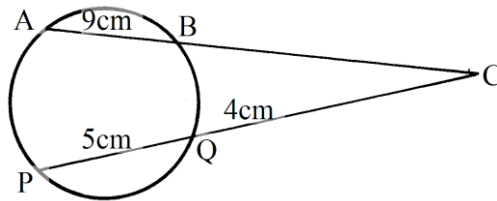



**SECTION II (50 MARKS)**

**Answer only five questions in this section**

17. (a) Salome invested Ksh. 250,000 for  $2\frac{1}{2}$  years in an account which paid 16% compound interest p.a. The interest is compounded quarterly. At the end of  $2\frac{1}{2}$  years she withdrew all the amount and spent it to the nearest thousands to buy four similar motor cycles. She earned an average of Ksh. 10,000 from each motorcycle per month.

(i) the amount she withdrew at the end of  $2\frac{1}{2}$  years.

(2mks)

(ii) the cost of each motorcycle.

(2mks)

(iii) the total earnings from the motorcycles for 3 years.

(2mks)

- (b) She decided to sell the motorcycles after depreciating at an average rate of 20% p.a for the 3 years.

Find:-

(i) the new value of each motorcycle after depreciation.

(2mks)

- (ii) the profit earned from her initial investment to the nearest shilling. (2mks)

18. The table below shows the distribution of ages in years of 50 adults who attended a clinic:-

Age	21-30	31-40	41-50	51-60	61-70	71-80
Frequency	15	11	17	4	2	1

- (a) State the medium class  
(1mk)
- (b) Using a working mean of 45.5, calculate:-
- (i) the mean age  
(3mks)
- (ii) the standard deviation  
(3mks)

(iii) Calculate the 6<sup>th</sup> docile.

(3mks)

19. An arithmetic progression (AP) has the first term  $a$  and the common difference  $d$ .

(a) Write down the third, ninth and twenty fifth terms of the AP in terms of  $a$  and  $d$ .

(1mk)

(b) The AP above is increasing and the third, ninth and twenty fifth terms form the first three

consecutive terms of a Geometric Progression (G.P) The sum of the seventh and twice the sixth terms of the AP is 78. Calculate:-

(i) the first term and common difference of the AP.

(5mks)

(ii) the sum of the first nine terms of the AP.

(2mks)

(iii) The difference between the fourth and the seventh terms of an increasing AP.

(2mks)

20. The probability that three candidates; Anthony, Beatrice and Caleb will pass an examination are  $\frac{3}{4}$ ,  $\frac{2}{3}$  and  $\frac{4}{5}$  respectively. Find the probability that:-

(a) all the three candidates will pass

(2mks)

(b) all the three candidates will not pass.  
(2mks)

(c) only one of them will pass  
(2mks)

(d) only two of them will pass.  
(2mks)

(e) at most two of them will pass.  
(2mks)

21. (a) Complete the table below for the function  $y = (3 - x)(x + 1)$

x	-3	-2	-1	0	1	2	3	4
x+1	-2	-1		1		3	4	
3-x	6	5	4		2	1		-1
y	-12	-5		3	4		0	-5

(2mks)

- (b) Use the values in the table to draw the graph of  $y = (3 - x)(x + 1)$ . Use the following scale.

Horizontal axis 2cm for 1 unit

Vertical axis 1cm for 1 unit.

(3mks)

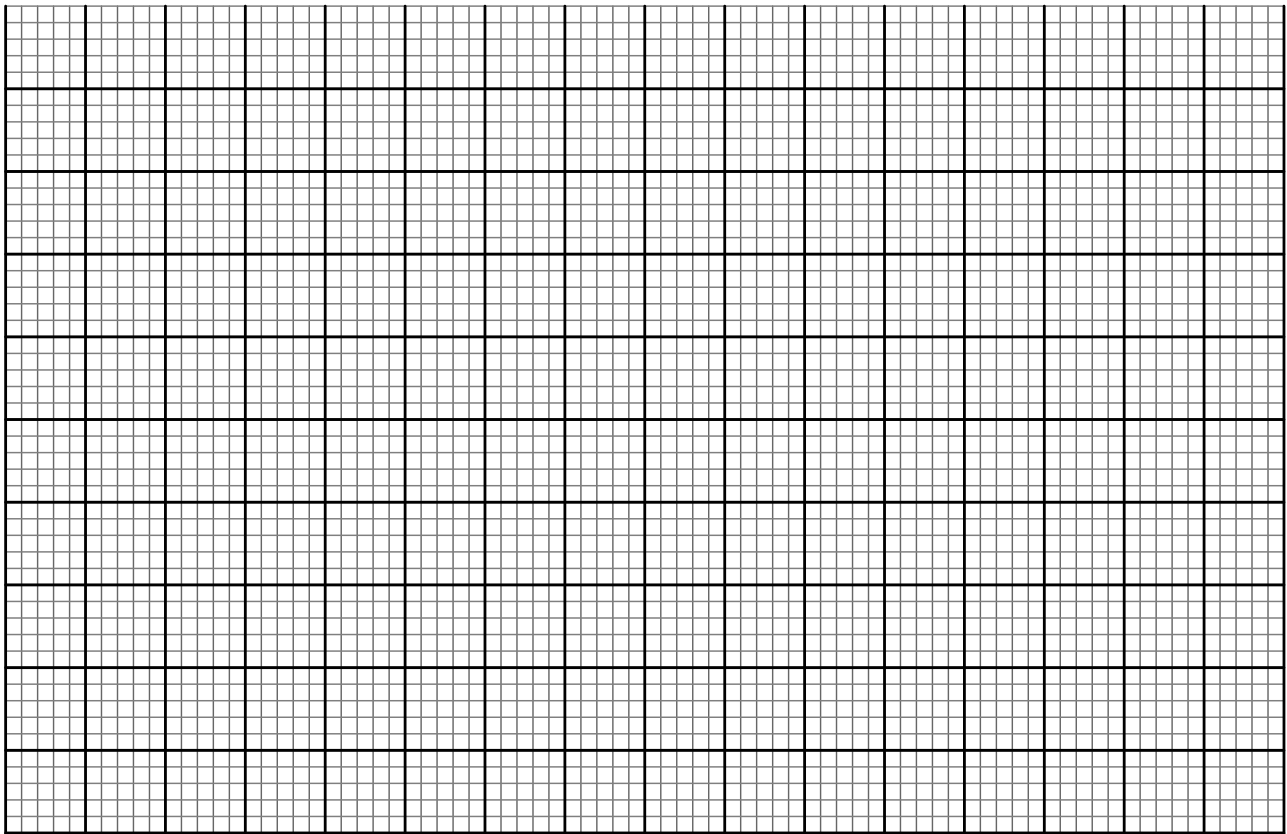

- (c) Use your graph in part (b) above to solve the following quadratic equations

(i)  $-x^2 + 2x + 3 = 0$

(2mks)

(ii)  $-x^2 + x + 6 = 0$

(3mks)

22. Use a ruler and a pair of compasses only all constructions in this question.

(a) Construct the rectangle ABCD such that  $AB = 7.2\text{cm}$  and  $BC = 5.6\text{cm}$ .

(3mks)

(b) Constructs on the same diagram the locus  $L_1$  of points equidistant from A and B to meet

with another locus  $L_2$  of points equidistant from AB and BC at M. measure the acute angle formed at M by  $L_1$  and  $L_2$ .

(3mks)

(c) Construct on the same diagram the locus of point K inside the rectangle such that K is less than 3.5cm from point M. Given that point K is nearer to B than A and also nearer

to BA than BC, shade the possible region where K lies. Hence calculate the area of this region.

Correct to one decimal place.

(4mks)

23. The diagram below, not drawn to scale shows part of the curve  $y = x^2 + 5$  and the line  $y = 8 - 2x$ . The line intersects the curve at points C and D. Lines AC and BD are parallel to the y-axis.

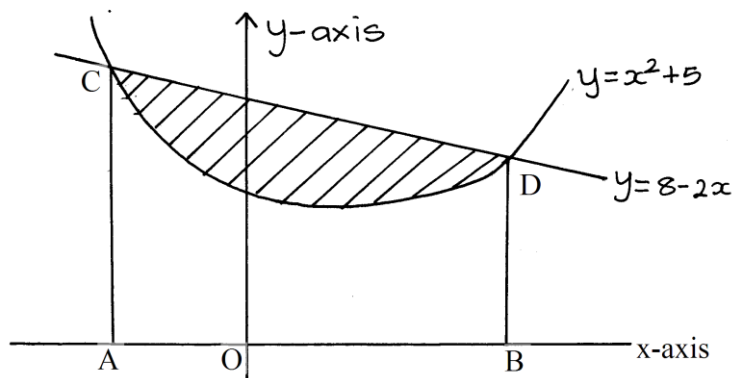

- (a) Determine the coordinates of C and D.

(4mks)

- (b) Use integration to calculate the area bounded by the curve and the x-axis between the



points C and D.

(3mks)

(c) Calculate the area enclosed by the lines CD, CA, BD and the x-axis.

(3mks)

(d) Hence determine the area of the shaded region.

(1mk)

24. A tailoring business makes two types of garments A and B. Garment A requires 3 metres of material while garment B requires  $2\frac{1}{2}$  metres of material. The business uses not more than 600 metres of material daily in making both garments. It must make not more than 100 garments of type A and nor less than 80 of type B each day.

(a) Write down three inequalities from this information other than  $x \geq 0$  and  $x \geq y$ , where x is the number of garments of type A and y the number of garments of type B.

(3mks)

(b) Graph these inequalities.

(3mks)

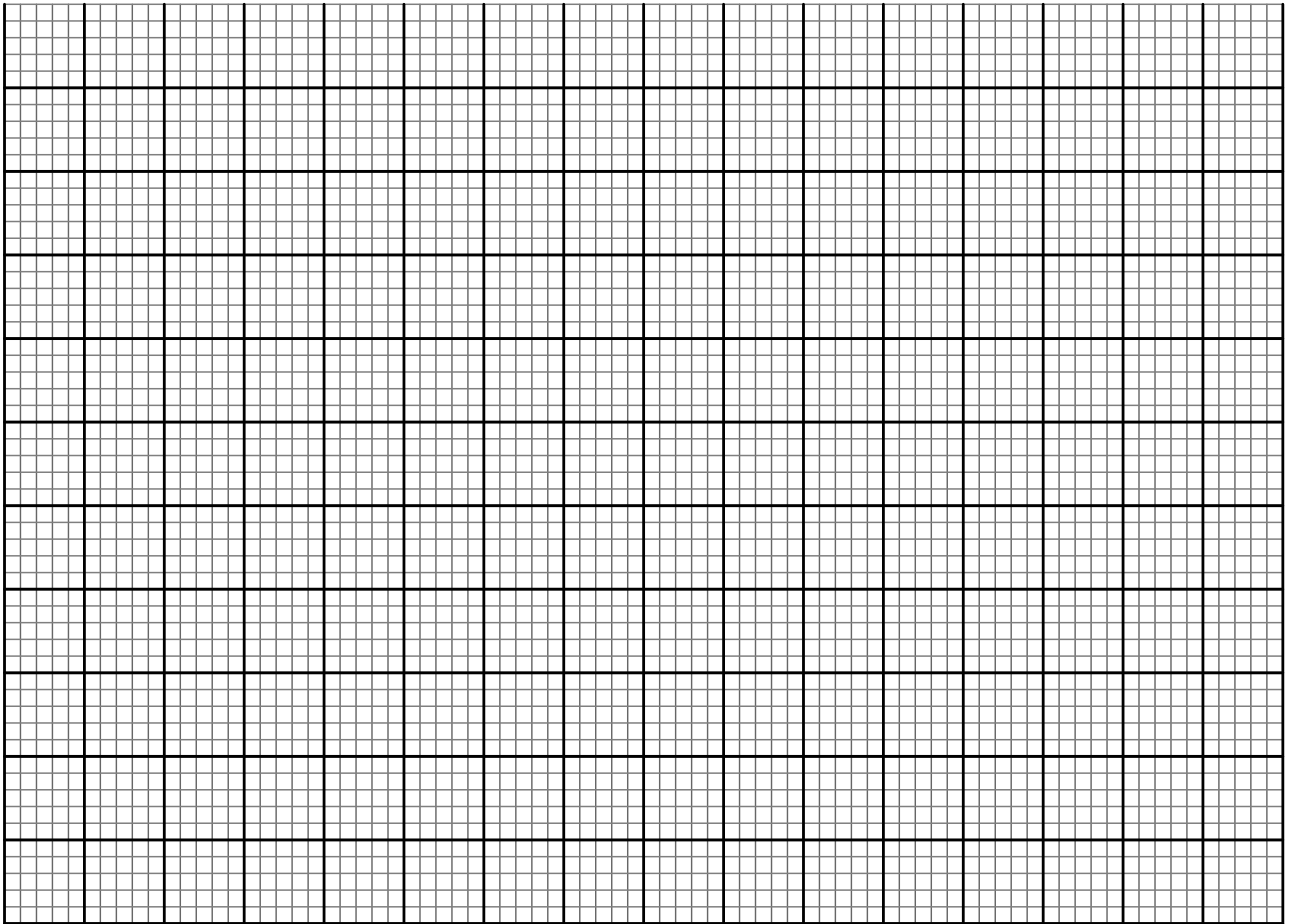

- (c) If the business makes a profit of sh 80 on garment A and a profit of sh. 60 on garment B, how many garments of each type must it make in order to maximize the profit and what is the total profit?  
(4mks)

# CROSSCOUNTRY MOCKS

## AGRICULTURE

### Paper 1

#### SECTION A: (30 MARKS)

Answer all questions from this section in the spaces provided.

1. Differentiate between:  
(a) Extensive and intensive farming systems. (1

(b) Aqua culture and apiculture.

2. State **two** disadvantages of pastoral nomadism system of farming. (1  
mark)

3. State **two** ways in which soil depth influences crop production. (1  
mark)

---

---

4. Give **two** ways of increasing light intensity in crop production.

---

---

---

5. Name **two** types of micro-catchments commonly used in water conservation. (1  
mark)

---

---

---

6. Give **four** ways of acquiring land for agricultural use in Kenya today. (2 marks)

---

---

---

---

443/1 2  
7. State **four** roles of mulch in soil and water conservation. (2 marks)

---

---

---

8. Give **four** ways of water harvesting in a farm. (2 marks)

---

---

---

9. State **four** methods that make weeds be competitive with desired crops in regard to successful means of propagation. (2 marks)

---

---

---

10. A farmer is to apply a compound fertilizer 20-30-0 on a vegetable plot measuring 5m long by 4m wide at the rate of 200kg/ha. Calculate the amount of fertilizer the farmer requires for the plot (show your working). (3 mark)

11. State **four** advantages of drip irrigation. (2 marks)

---

---

---

---

3

12. (a) State **two** positive effects of high temperatures on crop production. (1 mark)

---

---

(b) What is forage defoliation? (1 mark)

---

13. State **two** importance of drainage of land. (2 marks)

---

---

14. Define the term opportunity cost. (1 mark)

---

15. State **four** effects of soil erosion. (2 marks)

---

---

16. Name **two** methods used to control weeds in pastures. (1 mark)

17. Give **four** reasons why seeds may fail to germinate after planting. (2 marks)

4

**SECTION B: (20 MARKS)**

**Answer all the questions in this section in the spaces provided.**

18. The diagram **below** shows a method of crop propagation.

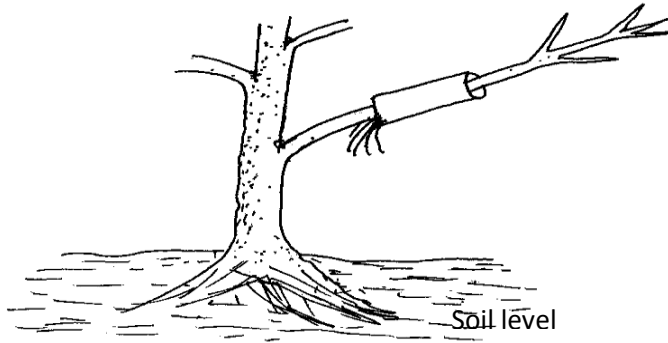

(i) Identify the propagation method illustrated above. (1 mark)

(ii) State **three** ways of initiating faster root development in propagation method illustrated. (3 marks)

19. Study the diagram **below** and answer the questions that follow.

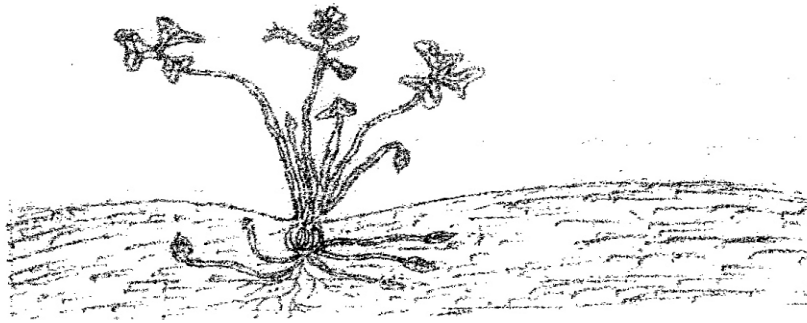

(i) Identify the weed. \_\_\_\_\_ (1 mark)

(ii) State the reason why it is hard to control the above named weed. \_\_\_\_\_ (1 mark)

\_\_\_\_\_  
(iii) Classify the above weed according to the life cycle. \_\_\_\_\_ (1 mark)

443/1

5

20. The diagram **below** illustrates how a plucking table is developed in a given crop.

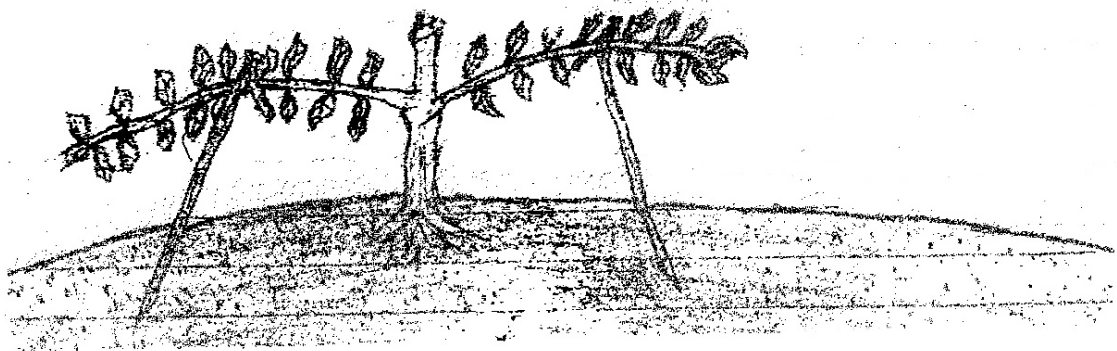

(i) Identify the crop where the above practice is carried out. \_\_\_\_\_ (1 mark)

(ii) Name the method. \_\_\_\_\_ (1 mark)

- (iii) Mention **three** advantages of pruning a crop. (3)

---

---

---

21. The diagram **below** illustrates a tomato fruit infested by a certain pest.

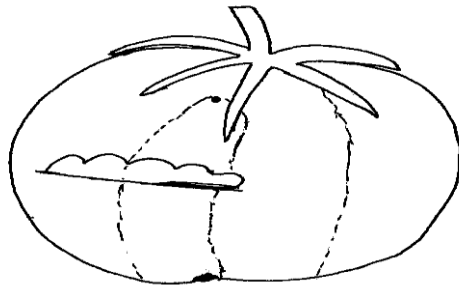

- (i) Identify the pest. \_\_\_\_\_ (1 mark)

- (ii) State the damage caused by the pest on the fruit. (1)

- (iii) Name **one** alternate host of the pest in the diagram. (1 mark)

- (iv) State **two** methods of controlling the pest. (2 marks)

22. A plot of land measures 6.6m long by 3.6m wide. The plot is prepared for planting cabbages at a spacing of 60cm by 60cm. the outermost row start 30cm from the edges all around the plot. Calculate:-

- (i) the number of rows falling on the width side of the plot. (1 mark)

- (ii) the number of cabbages seedlings that should be planted in the plot. (Show your working).

(2 marks)

**SECTION C: (40 MARKS)**

**Answer any TWO questions in this section in the spaces provided after question 25.**

23. Describe the production of irrigated rice under the following sub-headings.

**FOR MARKING SCHEMES CALL/TEXT/WHATSAPP 0705525657** 40



- (a) Land preparation. (7 marks)
- (b) Water control. (5 marks)
- (c) Fertilizer application (3 marks)
- (d) Weed control. (5 marks)
24. (a) Explain various management practices that can be carried out by a farmer to maintain soil fertility on his farm. (10 marks)
- (b) Explain **five** ways in which soil loses its fertility. (5 marks)
- (c) Explain **five** importance of soil organic matter. (5 marks)
25. (a) State and explain **five** factors that influence spacing in crops. (10 marks)
- (b) State and explain **five** general methods of crop pest and disease control. (10 marks)

# **CROSS COUNTRY MOCKS**

443/2

## **AGRICULTURE**

### **Paper 2**

#### **SECTION A (30 MARKS)**

*Answer ALL the questions in this section in the spaces provided.*

1. List **one** tool used in tightening barbed wire when constructing a fence. (½mk)
2. State **four** reasons for maintaining wheelbarrow in the farm. (2mks)
3. State any **four** reasons for castrating a goat. (
4. a) i) Name any **two** dairy goats that can be reared by a farmer.  
b) State any **six** practices carried out to improve the production of low yielding dairy goat.
5. a) Distinguish between inbreeding and line breeding (1mk)  
b) State any **three** importance of cross breeding. (1½mks)
6. a) Explain the meaning of the term intermediate host as used in livestock production. ( )  
b) State the intermediate host of liver fluke. (½mk)
7. State any **four** ways of improving the work output of draught animal. (2mks)
8. Explain any **four** reasons why bees swarm away. (2
9. State any **four** factors that may lower the quality of honey. (2
10. State any **three** factors that may cause early weaning in heifers. (1½mks)
11. Give **one** function of chalazae. (½mk)
12. State **four** factors that may cause stress in layers. (2mks)
13. State **four** ways of stimulating a lactating cow. (2mks)
14. Give **two** hormones essential in the process of milk production from a lactating cow. (1mk)

15. State **four** predisposing factors in mastitis in a high yielding cow (2mks)
16. State any **two** uses of phosphorus in livestock nutrition. (1mk)
17. Give **four** maintenance practices of a tractor battery. (2mks)

**SECTION B. (20 MARKS)**

*Answer ALL the questions in this section in the spaces provided.*

20. Identify the tools and equipment drawn below.

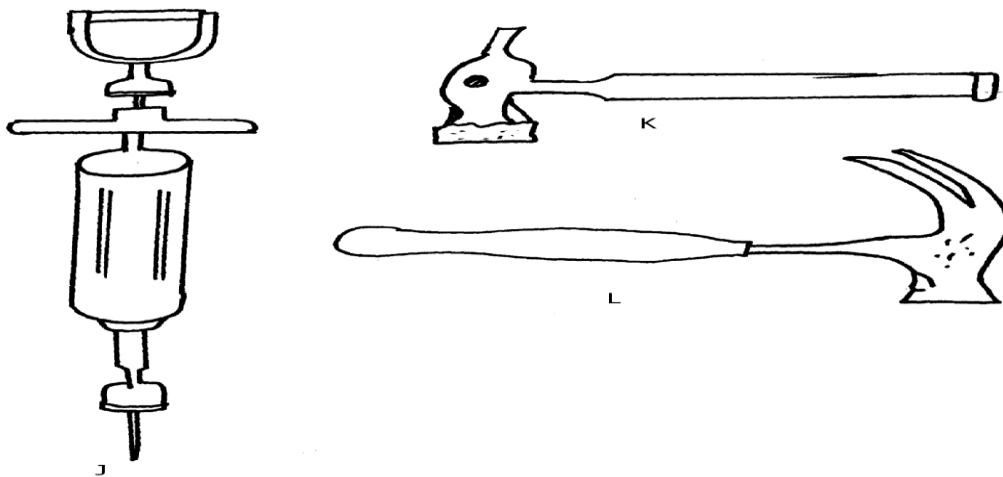

- i) Identify tools/equipment J, K and L (1½ mks)
- ii) State the use of J and K (2mks)
- iii) Give **one** functional similarity between K and L. (1mk)
- iv) Give **two** maintenance practices that should be carried out in too J. (2mks)

21. The diagram below shows parts of a plunge dip. Study the diagram and answer the questions that follow.

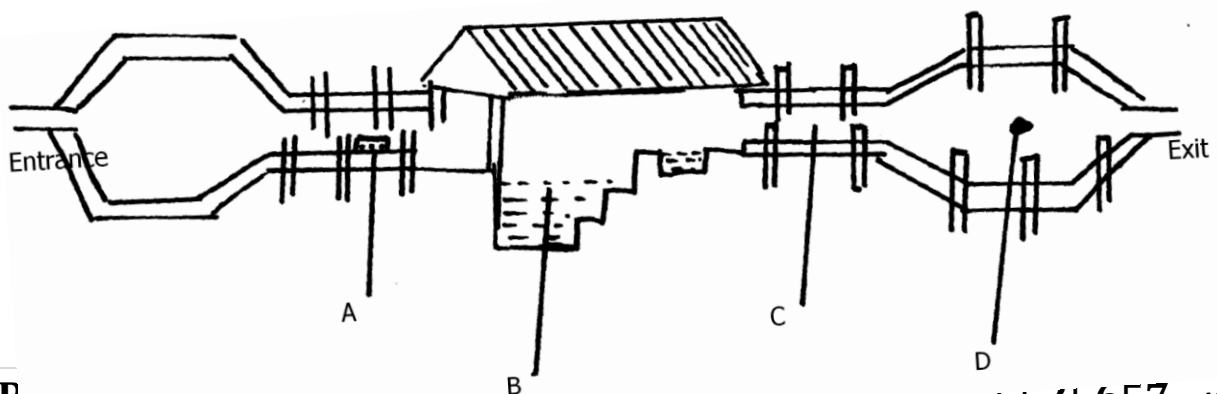

- i) Name parts A, B,C and D (2mks)
- ii) Give **two** reasons why cattle are held for sometime in part C. (2mks)
- iii) State **four** maintenance practices carried out on part D. (2mks)

22. The following diagram illustrates a disease symptom in cattle. Study it carefully and answer the questions that follow.

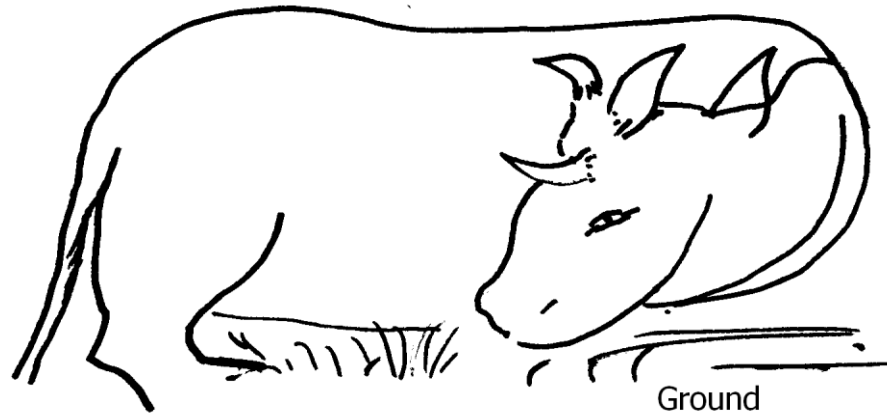

- a) Identify the disease in cattle with the shown symptoms. (1mk)
- b) Give **two** other causes of the disease named in (a) above. (2mks)
- c) Apart from the symptom shown on the diagram, state other two symptoms of the disease. (2mks)

23. Study the following diagram showing the behaviour of chicks with temperature variations in a brooder.

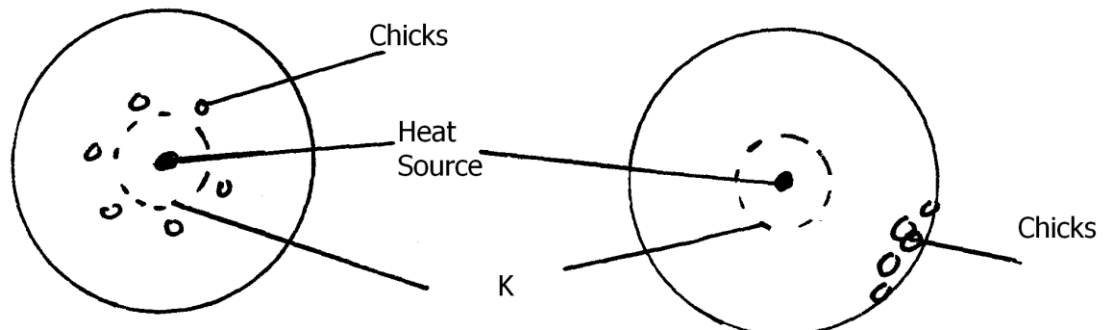

- a) Identify part K. (½ mk)
- b) Describe the behaviour of chicks in X and W (2mks)

SECTION C. (40 MARKS)

*Answer any two questions from this section in the spaces provided.*

24. a) Describe the uses of the various tools used in the fixing of barbed wire fence on the posts.  
(6mks)
- b) Outline **eight** uses of fences in the farm. (8mks)
- c) Describe the functional differences between mouldboard and disc plough.  
(6mks)
25. a) Outline **three** factors considered in the siting of a fish pond. (3mks)
- b) Describe **seven** management practices carried out on a fish pond to maximize the harvest.  
(7mks)
- c) Using the heat method, describe the procedure of processing honey. (10mks)
26. a) Describe the life cycle of a two-host tick.  
(6mks)
- b) Describe how physical methods are used to control ticks in a herd of cattle. (4mks)
- c) Describe the digestion of grass in the rumen of a ruminant animal.  
(10mks)

# CROSS COUNTRY MOCKS

## BIOLOGY

### Paper 1

1. State the branch of Biology that would be used in solving the problem of disputed parentage. (1mk)

.....  
.....

2. (a) What is the formula of calculating linear magnification of a specimen when using a hand lens?

.....  
.....

- (b) Give a reason why staining is necessary when preparing specimens for observation under the microscope (1mk)

.....  
.....

3. State **two** functions of Golgi apparatus. (2mks)

.....  
.....

4. State the importance of the following processes that take place in the nephrons of a human kidney

Ultra filtration (1mk)

.....

Selective reabsorption (1mk)

.....

5. (a) Name a disease of the liver whose symptom is jaundice (1mk)

.....  
(b) State the causative agent of:

(1mk)

(i) Cholera

(1mk)

.....  
(ii) Candidiasis

(1mk)

.....  
6. The diagram below shows a section through a plant organ

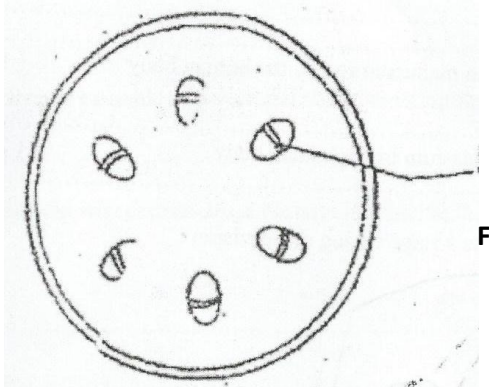

(a) (i) Name the class of the plant which the section was obtained

(1mk)

.....  
(ii) Give a reason for your answer in (a) (i) above

(1mk)

.....  
(b) State the functions of the part labelled **F**

(1mk)

7. Describe what happens during the light stage of photosynthesis (2mks)

.....  
.....

8. (a) State **two** environmental conditions that can cause seed dormancy (2mks)

.....  
.....

(b) Name the part of a bean that elongates to bring about epigeal germination (1mk)

.....

9. (a) Name a fat soluble vitamin manufactured by the human body (1mk)

.....

(b) State **two** functions of potassium in the human body (1mk)

.....  
.....

10. The diagram below represents a stage during cell division

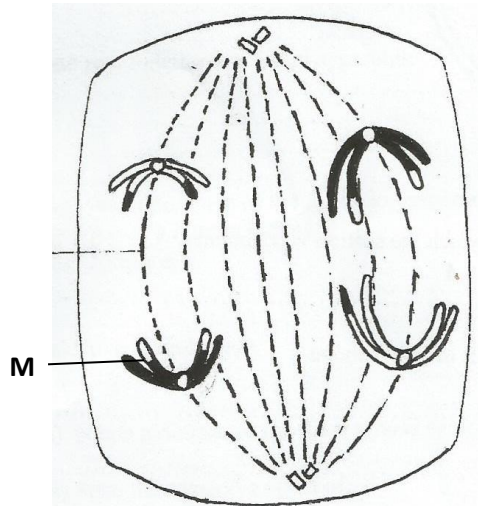

(a) (i) Identify the stage of cell division

(1mk)

.....



(ii) Give **two** reasons for your answer in (a) (i) above  
(2mks)

.....  
.....

(b) Name the structures labeled **M**  
(1mk)

.....

11. Name a support tissue in plants that is not thickened with lignin (1mk)

.....

12. (a) (i) What is meant by vestigial structures ? (1mk)

.....  
.....

(ii) Give an example of vestigial structure in human (1mk)

.....

(b) Explain why certain drugs become ineffective in curing a disease after many years of use. (2mks)

.....  
.....

13. The diagram below represents a simple reflex arc.

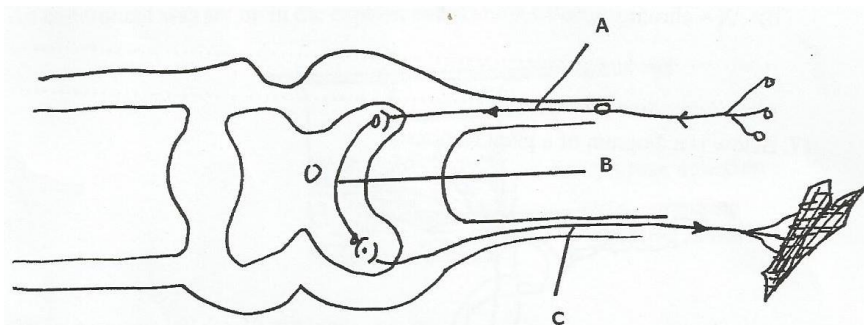

(a) Name the parts labeled **A, B, C**.

(3mks)

A .....

**B** .....

**C** .....

(b) What is the role of part A

(1mk)

.....

14. (a) In which part of the cell do the following stages of respiration take place. (2mks)

(i) Glycolysis

.....

.....

(ii) Kleb's Cycle

.....

.....

(b) In which of the **two** stages above is most energy produced?

(1mk)

.....

15. Explain why drug addicts are prone to HIV infection. (2mks)

.....

.....

16. Name a sex- linked trait associated with:

(i) Y – Chromosome

(1mk)

.....

.....

(ii) X – Chromosome

(1mk)

.....  
.....

17. Below is a diagram of a plant response.

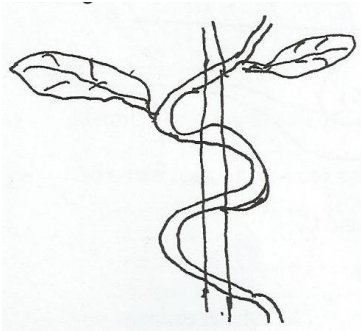

(i) Name the plant response illustrated above.

(1mk)

.....

(ii) State the importance of the named response above to the plant.

(1mk)

.....

18. (a) (i) A man's urine gave positive reaction with Benedict's solution. Name the disease he was suffering from.

(1mk)

.....

(ii) State **two** ways in which the symptoms of the condition in (a) above can be controlled.

(2mks)

.....

.....

(b) Name the hormones involved in regulating glucose level in blood.

(2mks)

.....  
.....

19. (a) Name **two** structures for gaseous exchange in aquatic plants.

(2mks)

.....  
.....

(b) What is the effect of contraction of the diaphragm muscles during breathing in mammals?

(3mks)

.....  
.....

20. An experiment was set up in the experiment as shown below.

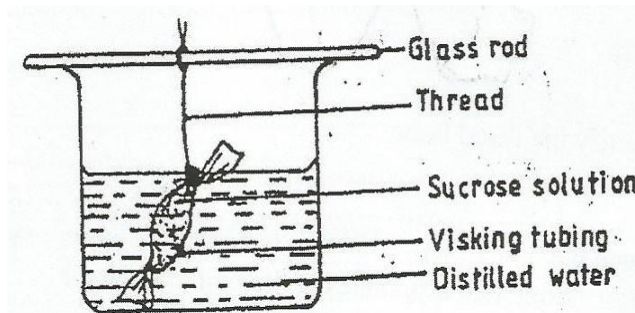

The set up was left for 30 minutes.

(a) State the expected results.

(1mk)

.....

(b) Account for your answer in (a) above

(2mks)

.....  
.....

21. State **two** structural modifications of nephrons found in desert mammals (2mks)

.....  
.....

22. (a) State **two** characteristics of Monera that are not found in other kingdoms (2mks)

.....  
.....

(b) Name the class to which a termite belongs

(1mk)

.....

23. The diagram below shows two fused bones of a mammal

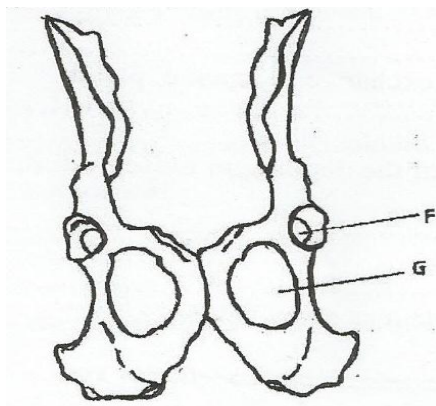

(a) Identify the fused bone

(1mk)

.....

(b) Name the

(i) Bone that articulates at point labeled **F**

(1mk)

.....

(ii) Type of the joint that is found at the point labeled **F** (1mk)

.....

(iii)The hole labeled **G**

.....

24. Which structure in the ear detects

a. Sound waves .....(1mk)

b. Change in posture ..... (1mk)

25. A certain species of flowering plant relies entirely on sexual reproduction for propagation. The chromosome number of the cell in the ovarian wall is 16. How many chromosomes are in

(a) The pollen tube nucleus.

(1mk)

.....  
.....

(b) A cell of the endosperm

(1mk)

.....  
.....

26. The diagram below represents an eye defect.

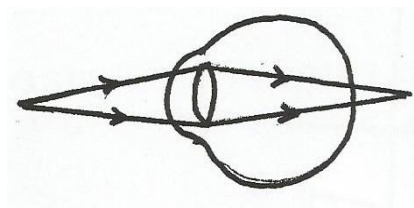

(i) Name the eye defect represented

(1mk)

.....

(ii) How can the defect be corrected

(1mk)

.....  
.....

27. (a) Distinguish between population and community

(2mks)

.....  
.....

(b) Name the method that can be used to estimate the population size of the following organisms

(i) Fish in a pond

(1mk)

.....

(ii) Black jack in a garden

(1mk)

.....

28. (a) An individual has blood group A.

List the possible genotypes.

(1mk)

.....

(b) What is the significance of a test cross.

(1mk)

.....

29. The diagram below shows a mature embryo sac.

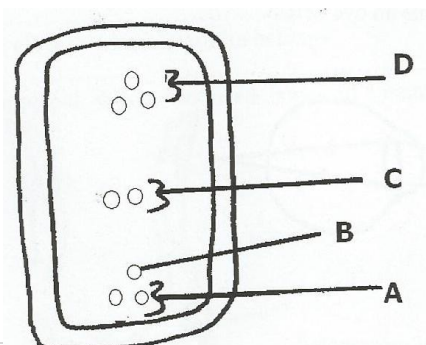

(a) Name the part labeled **A** and **D**.

(2mks)

**A** .....

**D** .....

(b) Which of the parts labelled above is fertilized to form a diploid zygote.

(1mk)

.....



# CROSS COUNTRY MOCKS

231/2  
BIOLOGY  
PAPER 2  
(THEORY)

**SECTION A – (40 MARKS)**

**Answer ALL questions in the question**

1. (a) Name the gaseous exchange structure in the following organisms.

(i) Amoeba  
mar

(1

.....

.....

(ii) Grasshopper

(1mark)

.....

.....

(b) The diagram below illustrates the structure of a gill from a bony fish.

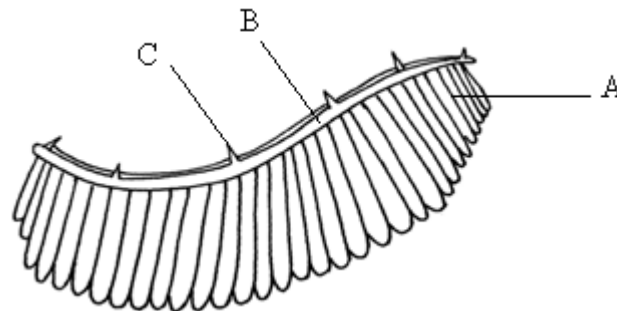

(i) Name the parts labelled A, B, C

(3

marks)

A .....

B .....

C .....

(ii) State the function of the part labelled C

(1

mark)

.....

.....

(iii) How is part A adapted to carry its functions  
(marks)

(2)

.....  
.....  
.....

2. The diagram below represents a transverse section of a young stem.

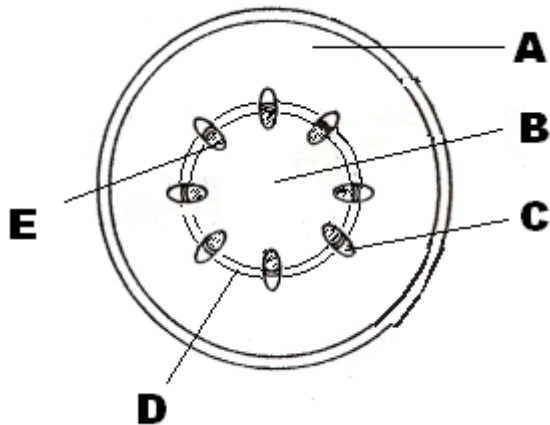

(a) Name the parts labelled A and B  
(marks)

(2)

A

.....  
.....

B.

.....  
.....

(b) State the functions of the plants labelled C, D and E

C

.....

D

.....

E

.....

(c) List three differences between the section shown above and one that would be obtained from the root

of the same plant.

(3marks)

.....

.....

.....

.....

.....

3. (a) The diagram below shows an experimental set – up by form two students.

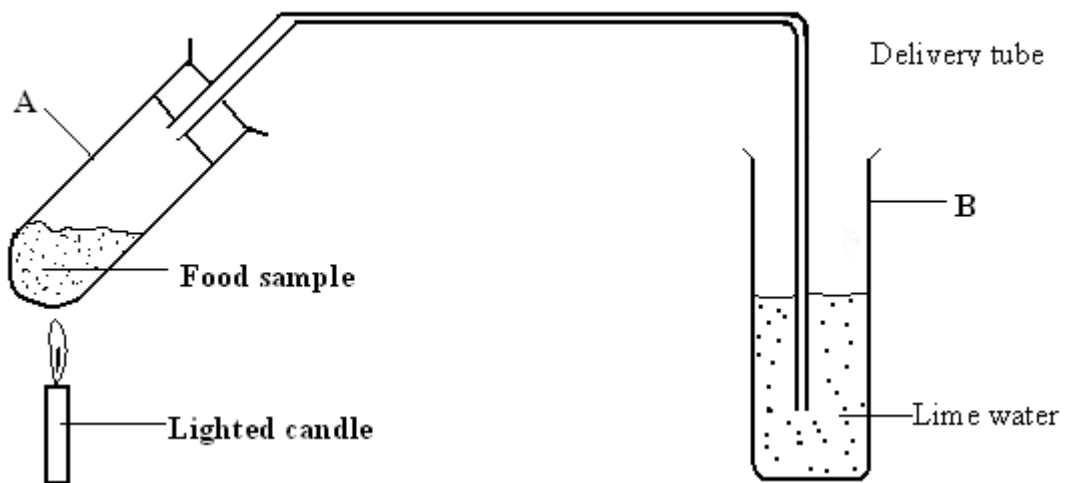

(i) State the aim of the experiment.

(1mark)

.....

.....

.....

(ii) State the expected results at the end of the experiment.

(2

marks)

.....

.....

.....

(iii) What conclusion can you make from this experiment?

(1

mark)

.....  
.....

(b) Examine the diagram which shows a set used to demonstrate a certain process.

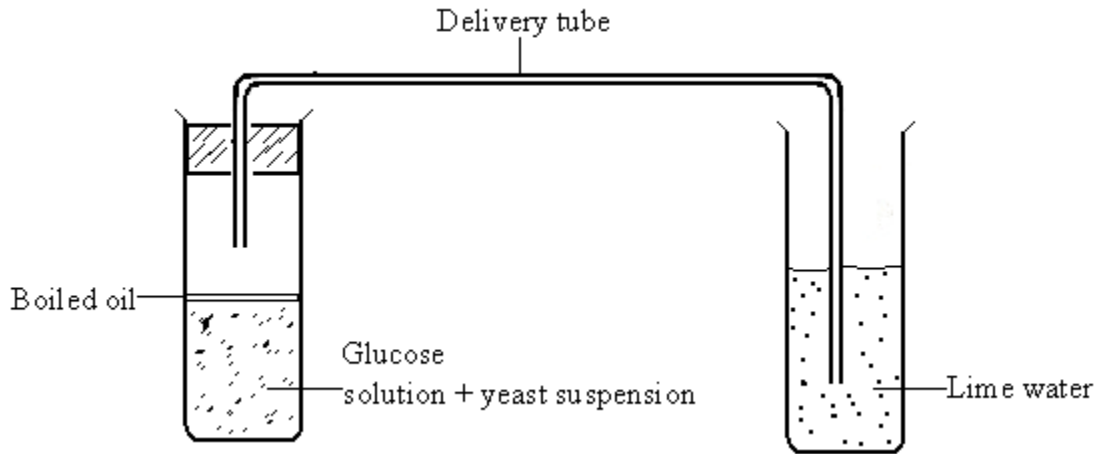

(i) State the aim of the experiment.

(1

mark)

.....  
.....  
.....

(ii) Why was it necessary to boil the glucose solution before adding the yeast suspension?

(1

mark)

.....  
.....  
.....  
.....

(iii) Why was it necessary to cool the glucose before adding the yeast suspension?

(1mark)

.....  
.....

(iv) Why was the oil layer added? (1 mark)

.....  
.....

4. (a) In each case, state one problem faced by fresh water fish and marine fish in their habitats.

(i) Marine water fish (1 mark)

.....  
.....

(ii) Fresh water (1mark)

.....  
.....

(b) State two ways through which each of the fish overcome the problems identified in (a) above.

(i) Fresh water fish (2 marks)

.....  
.....

.....  
.....

(ii) Marine water fish (2marks)

.....  
.....

.....  
.....

.....

(c) Explain why a person discharges urine more often when the environment temperatures are low than when they are high. (2 marks)

.....  
.....

5. The diagram below shows the treatment given to strips of barbadoes stem which were cut lengthwise from the mainstem.

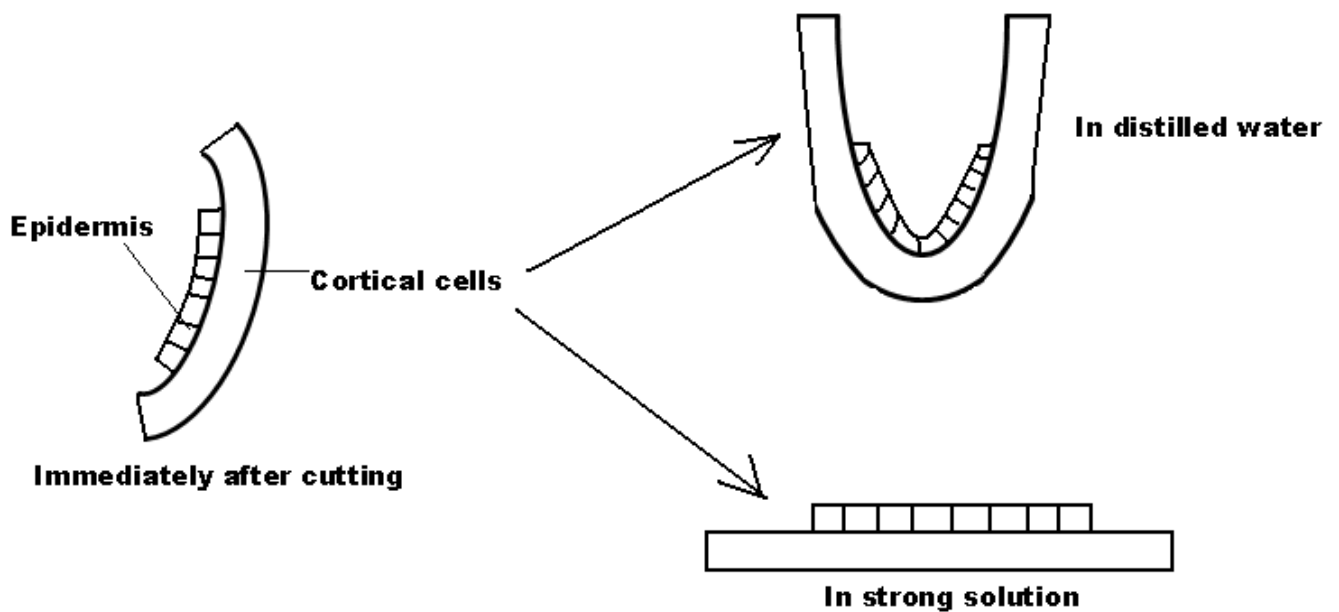

(a) Account for the results obtained when the strips were put in:-

(i) Distilled water (3 marks)

.....  
.....  
.....

(ii) Strong salt solution (3marks)

.....  
.....

.....  
.....

(b) Why did the strips curl slightly outwards immediately after being cut. (2 marks)

.....  
.....

6. The following data represent the development in dry mass of germinating seedlings within 18 weeks.

Time (wks)	0	1	2	4	6	10	13	15	16	18
Dry mass (gm)	1	2	3	10	18	32	44	45	44	38

(a) Plot a graph of dry mass against time. (6 marks)

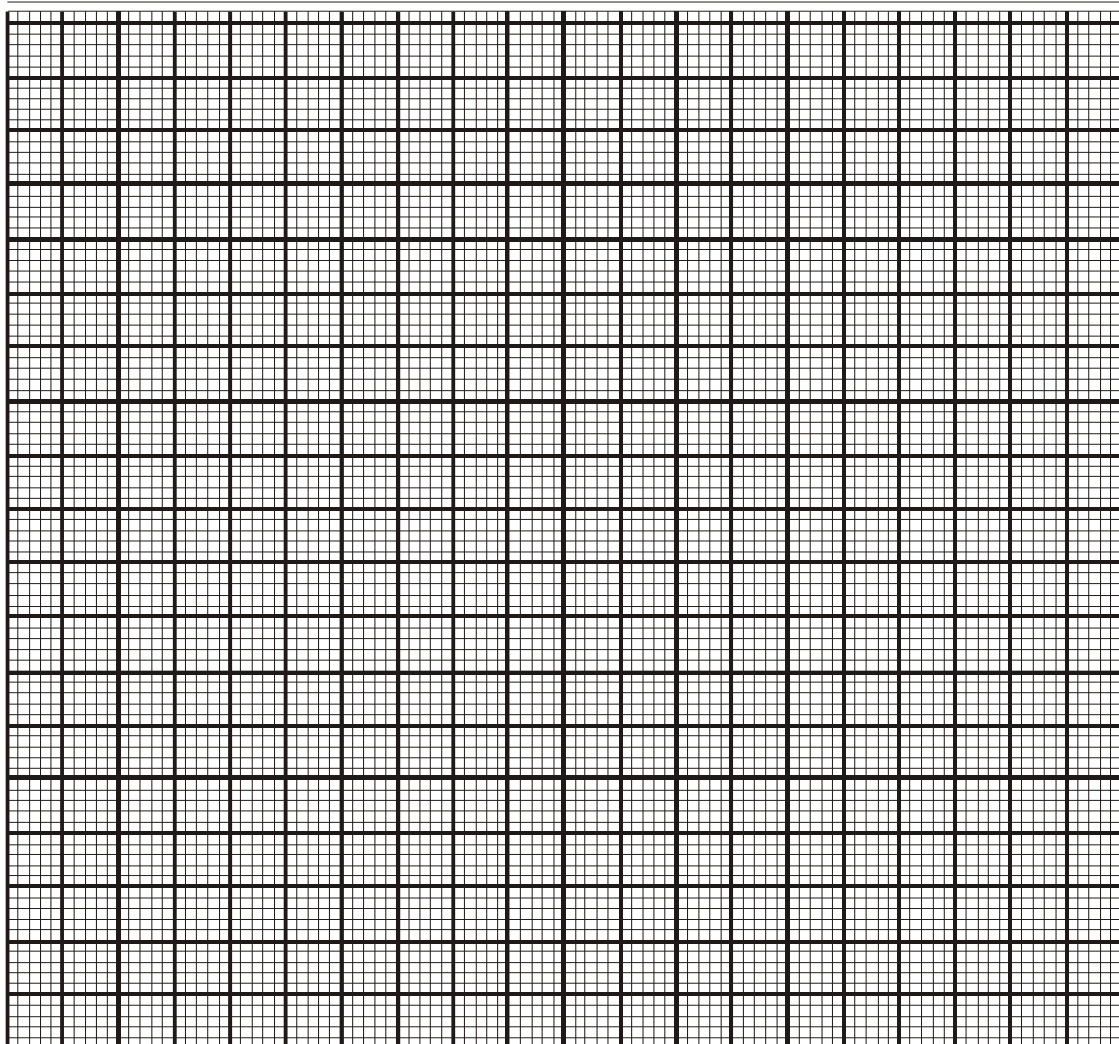

(b) With reference to the graph, explain the changes in dry mass between.

(i) Week 0 to 2 (2 mark)

.....  
.....

(ii) Week 5 to 13 (2mark)

.....  
.....

(iii) Week 16 to 18 (2 mark)

.....  
.....

(c) (i) What is the significance of time zero.

(1mark)

.....  
.....

(ii) What difference would be expected from the above results if the experiment started with the seeds. Give a reason.

.....  
.....  
.....

(d) (i) Describe how you carry out the experiment to obtain dry mass in the respective weeks. (3 marks)

.....  
.....  
.....

(ii) State one advantage of using dry mass and one disadvantage of using fresh weight in estimating growth.

Advantage (1 mark)



.....  
Disadvantage (1  
mark)  
.....  
.....  
.....  
.....

7. Blood has two broad functions, namely protective and transport.  
(a) Explain how blood is involved in transport, stating the constituents of blood involved. (4 marks)  
(b) Describe how blood protects the body (4 marks)
8. Describe how seeds and fruits are adapted to different modes of dispersal. (20 marks)

# CROSS COUNTY EXAMS

## PAPER 1

### BUSINESS STUDIES

1. Mention **four** methods that countries use to restrict importation of goods. (4mks)

---

---

---

---

2. Highlight **four** limitations of barter system of trade. (4mks)

---

---

---

---

3. Study the following diagram and state the missing terms. (4mks)

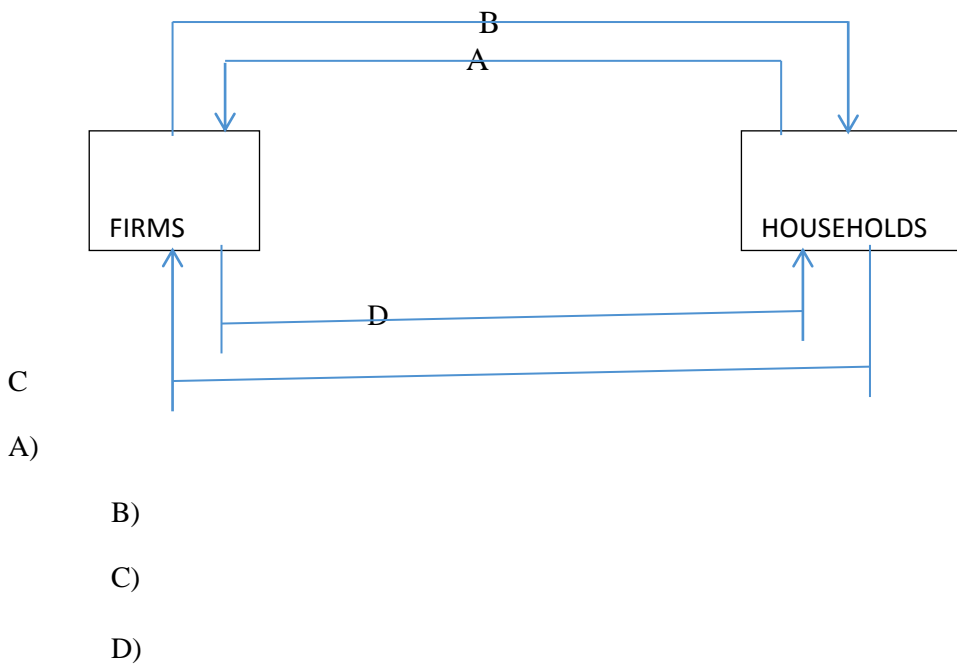

4 Give **four** reasons why employers are expected to provide their employees with insurance cover.

(4mks)

---

---

---

---

5. Highlight **four** problems that are likely to be faced by a firm as result of expansion of the entire industry. (4mks)

---

---

---

---

4. State **four** benefits that Kenya will reap after the completion of the Lamu Port & Lamu-South Sudan-Ethiopia Transport corridor (LAPSSET) project whose construction is underway.

(4mks)

---

---

---

---

---

4 Mention **four** features of capital as a factor of production. (4mks)

---

---

---

---

---

4. Outline **four** factors that may contribute to the ineffectiveness of a warehouse. (4mks)

---

---

---

---

---

5. Highlight **four** importance of subsidiary books. (4mks)

---

---

---

---

6. Enter the following transactions in the relevant ledger accounts (4mks)

- i) Purchased a Delivery van from CMC Motors for sh. 350,000 paying by cheque.
- ii) Atieno, a debtor, paid fully her account of sh. 18,000 in cash.
- iii) Deposited cash sh. 200,000 in the bank.
- iv) Sold goods to Kemboi for sh. 15,000 receiving cash.

7. Highlight **four** ways through which the physical environment can positively impact a business performance.(4mks)

---

---

---

---

8. Highlight **four** differences between monopoly and monopolistic market structures. (4mks)

---

---

---

---

9.State **four** characteristics of a departmental store. (4mks)

---

---

---

---

9. Give the meaning of the following terms as used in business. (4mks)

a) Franchising.

---

---

b) Check-off system

---

---

c) Amalgamations

---

---

d) Take-overs

---

---

10. Outline **four** importance of national census statistics in an economy. (4mks)

---

---

---

---

---

11. Highlight **four** challenges that entrepreneurs face when carrying out business activities. (4mks)

---

---

---

---

---

12. Outline **four** characteristics of a good tax system.(4mks)

---

---

---

---

13. Outline how scarcity, choice and opportunity cost are related. (4mks)

---

---

---

---

---

14. State **four** measures a business can put in place to safeguard office property. (4mks)

---

---

---

---

---

15. Highlight **four** ways in which Kenya Association of Manufacturers (KAM) ensures that their members do not exploit consumers. (4mks)

---

---

---

---

---

16. State any **four** essential elements of communication. (4mks)

---

---

---

---

17. The following table represents the demand for tomatoes.

price of tomatoes (Shs)	quantity demanded of tomatoes per week (Kgs)
-------------------------------	---

0	0
00	
50	
00	
50	

From the above demand schedule plot the demand curve for tomatoes. (4mks)

---

---

---

---

---

23. Outline any **four** roles played by intermediaries in the chain of distribution. (4mks)

---

---

---

---

---

24. Upendo Traders had the following information extracted from their books of accounts as at 31<sup>st</sup> December 2012.

h

apital ,500,000  
(01.01.2011)

rofit 24,440

rawings for the 5,220  
year

apital ,000,000  
(31.12.2012)

Required:

Calculate additional investments for the year.

---

---

---

---

---

---

---

---

---

25. Outline **four** factors that might cause demand-pull inflation.  
(4mks)



# **CROSS COUNTRY EXAMS**

## **BUSINESS PAPER 2 INSTRUCTIONS TO CANDIDATES**

**Answer any 5 questions**

**All question carry equal marks.**

1. (a) Explain five important of Entrepreneurship to an economy. (10 mks)
- (b) Explain five effects of a declining populating to an economy. (10 mks)
2. (a) Outline the use of following source of documents as used in Home Trade. (10 mks)
- (b) Outline the use of the following source documents as used in Home Trade. (10 mks)
  - (i) catalogue
  - (ii) advice note
  - (iii) credit note
  - (iv) debit note
  - (v) invoice
3. (a) The following information was extracted from the books of Baraka Traders on 31<sup>st</sup> December 2011.

	Sh
Land and buildings	640,000
2 yr loan	250,000
Motor vehicles	400,000
Furniture	70,000
3 yr bank loan	360,000
Debtors	82,000
Creditors	95,000
Bank overdraft	67,000
Cash in hand	35,000
Capital in hand	490,000
Net profit	40,000
Stock	75,000

Required:

- (i) Prepared Baraka Traders balance sheet as at 31<sup>st</sup> December 2011. Clearly showing fixed assets, current assets, long-term liabilities and current liabilities. (6 mks)
- (ii) Calculate:

- Working capital (1 mk)
- Capital employed (1 mk)
- Borrowed capital (1 mk)
- Return on capital (1 mk)

(b) Explain five circumstances under which a business person would prefer written communication. (10 mks)

4. (a) With an aid of a diagram explain how price is determined through price mechanism  
(b) Outline five benefits of the “pooling of risks” to an insurance company. (10 mks)

5. (a) Explain five causes of cost-push inflation. (10 mks)

(b) Explain five circumstances under which a producer would prefer to sell his product directly to the consumer. (10 mks)

6. (a) Explain five importance of warehousing to a producer. (10 mks)

(b) The accounts Zawadi Traders showed the following balances on 1<sup>st</sup> January 2010. (10 mks)

	Sh
Cash	250,000
Debtors	60,000
Creditors	42,000
Stock	30,000
Bank loan	120,000
Motor vehicle	310,000

The following transitions took place during the month of January 2010.

2010

- Jan 2: Bought stock worth sh 50,000 n credit  
Jan 3: Cash sales sh 80,000  
Jan 5: Received sh 20,000 cash from debtors  
Jan 10: Paid part of loan sh 70,000 cash  
Jan 12: Paid creditors sh 52,000 cash  
Jan16: Bought office furniture sh 45,000  
Jan 20: Paid salaries sh 40,000 cash  
Jan 25: Deposited sh 100,000 into the bank

Required:

Record the above transactions in the relevant ledger accounts and balance the account on 31<sup>st</sup> January 2010.

# CROSS COUNTRY MOCKS

## CHEMISTRY

### PAPER 1

### THEORY

1. Identify and state the use of the apparatus represented below. (2 marks)

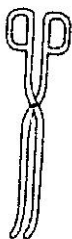

Name.....

Use.....

2. Give the systematic name of each of the compounds represented by the formulae below. (3 marks)

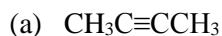

.....

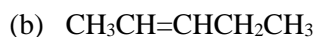

.....

3. A fixed mass of a gas occupies  $105\text{cm}^3$  at  $-14^\circ\text{C}$  and  $650\text{mmHg}$ . At what temperature will it have a volume of  $15\text{cm}^3$  if pressure is adjusted to  $690\text{mmHg}$ ? (3marks)

4. a) Using dots (.) and crosses (x) to represent electrons, show the bonding in the compounds formed between magnesium and fluorine. (Atomic numbers; Mg= 12, F=9) (1 mark)

- b) State one likely physical property of the compound formed between magnesium and fluorine in (a) above. (1 mark)

5. A set-up to investigate electrical conductivity of substances was assembled as shown below.

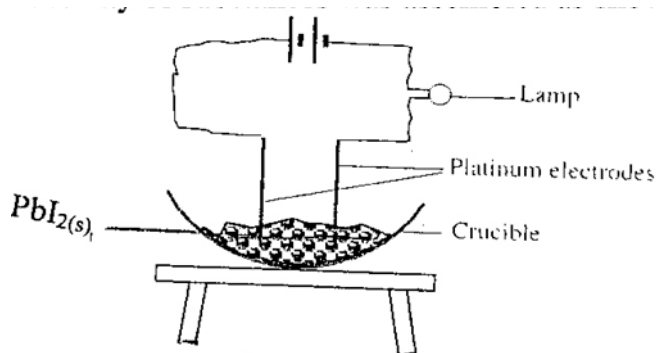

The bulb did not light.

- (a) What was missing in the set-up? (1 mark)

- (b) The bulb lit when the omission was corrected. Explain. (2 marks)

6. An oxide of copper in a porcelain boat was reduced by a stream of hydrogen. The results obtained were as follows;

Mass of porcelain boat = 4.5g

Mass of boat + Oxide = 6.40g

Mass of boat + Copper = 6.02 g

- i) Determine the empirical formula of the oxide. (3 marks)

- ii) If the relative formula mass of the oxide is 80, determine its chemical formula.  
(Cu = 64, O = 16) (1 mark)

7. Starting with copper metal, describe how to prepare solid copper (II) carbonate. (3 marks)

.....  
.....

8. The diagram below shows a 'jiko' when in use. Study it and answer the questions that follow

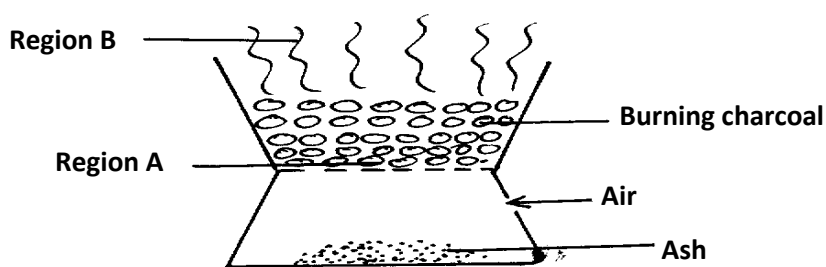

- (a) Identify the gas formed at region B (1mk)

.....  
.....

- (b) State and explain the observation made at region B (2mks)

.....

9. A student set up the following experiment to study the effect of heat on lead (II) nitrate.

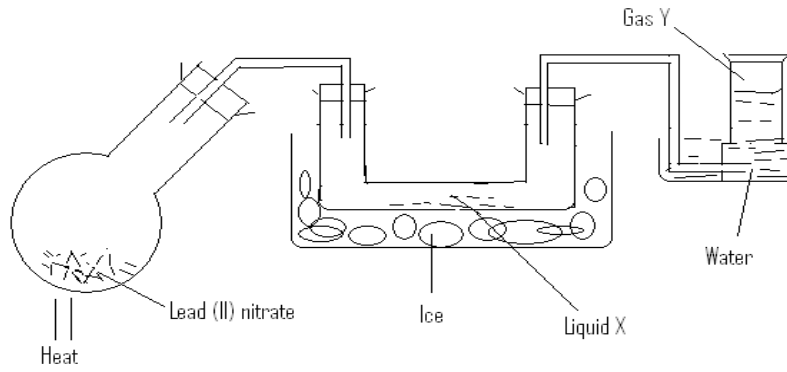

i) Identify liquid X (1 mark)

.....

ii) Describe the test for gas Y. (1 mark)

.....

.....

iii) Write a balanced chemical equation for the reaction. (1 mark)

.....

10. The set-up represented below can be used to separate ethanol from its mixture with water.

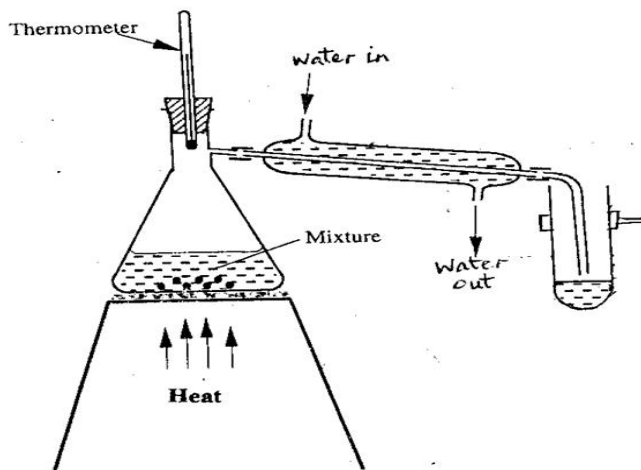

(a) Identify an error in the set-up. (1 mark)

.....

(b) Name this method of separation. (1 mark)

.....  
(c) What properties make it possible to separate ethanol from water by this method? (1 mark)

.....  
.....  
11. Describe how to distinguish between substances I and II .

(3 marks)

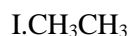

.....  
.....  
.....  
12. Element K has two isotopes  $^{20}\text{K}$  and  $^{22}\text{K}$  with relative abundance of 90% and 10% respectively.

a) What are isotopes?

(1 mark)

.....  
.....  
b) Determine the relative atomic mass of element K.

(2 marks)

13. Give one application of calcium oxide.

(1 mark)

.....  
.....  
14. Consider the diagram below.

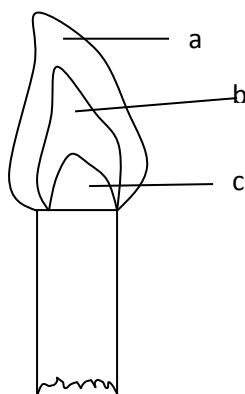

Name the regions labeled a, b, c.

(3 marks)

a .....

b .....

c .....

15. State one use of:

a) Calcium nitrate

(1 mark)

.....

b) Magnesium hydroxide

(1 mark)

.....

16.. Some moist iron wool was placed in a test tube and the tube was inverted and set up as shown below.

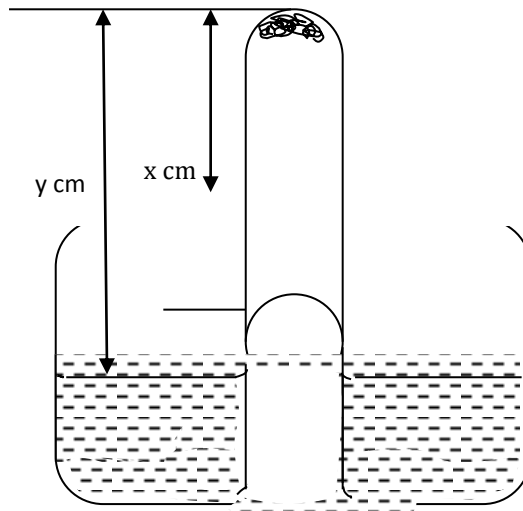

The apparatus was left for one week. The water level rose and iron wool turned red-brown.



(i) Write the chemical equation to show the rusting of iron. (1 mark)

.....

(ii) Write the expression for an approximate percentage. (1 mark)

.....

(iii) State two similarities between rusting and combustion.

(a)

.....(1 mark)

(b)

.....(1 mk)

17. Sulphur burns in air to form a gaseous product.

i) What is the colour of the flame of burning sulphur? (1 mark)

.....

ii) Give an equation for the reaction that takes place when the gaseous product is bubbled through water. (1 mark)

.....

iii) State one importance of the product formed in 17(ii) above. (1 mark)

.....

18. The pH values of some solutions labeled E to I are given in the table below. Use the information to answer the questions that follow.

pH	14.0	1.0	8.0	6.5	7.0
Solution	E	F	G	H	I

(a) Identify the solution with the highest concentration of hydroxide ions. Give a reason for your answer. (2 marks)

---

---

---

(b) Which solution can be used as a remedy for acid indigestion in the stomach?(1 mark)

---

19. Four metals are labeled P, Q, R and S (not actual symbols). Metal P displaces metal S from its oxide but cannot displace R from its oxide. Q when mixed with the oxide of R and heated, a reaction occurs.

Arrange the metals in order of reactivity, starting with the most reactive. (2 marks)

.....

20. A certain element Y has atomic number 15 and mass number of 31.

(a) Calculate the number of neutrons in the element. (1mk)

---

(b) Write the electron arrangement of the ion formed by element Y. (1mk)

---

(c) How would the atomic size of the above element compare with another atom X whose atomic number is 11 and mass number 23? Explain. (1mk)

---

---

21. The table below shows the first ionisation energies of elements P and Q.

Element	1 <sup>st</sup> Ionisation energy kJ/mole
P	494
Q	418

a) What do these values suggest about the reactivity of P compared to that of Q? Explain. (2 marks)

.....  
.....  
.....

a) State two factors that influence ionization energy. (1 mark)

.....  
.....

22. Steam is passed over heated iron filings in a combustion tube.

(a) Name the products of this reaction. (2 mark)

.....  
.....

(b) Write an equation for the reaction that occurs. (1 mark)

1. ....

..... Diamond and graphite are allotropes of carbon.

(i) What are allotropes? (1mk)

.....

.....In terms of structure and bonding explain why diamond is used in drilling through hard rocks while graphite is a lubricant (2mks)

.....

24. 30cm<sup>3</sup> of 0.5M hydrochloric acid was used to neutralize 25cm<sup>3</sup> of sodium hydroxide solution. Determine the concentration of sodium hydroxide in grams per litre. (3 marks)

(H=1, O=16, Na= 23)

25. The table below gives some information about the physical properties of four substances which are represented by letters. **L M N** and **K**.

Substance	Melting point	Heat of vaporization	Electrical Conductivity	
			Solid	molten
L	High	High	Poor	Poor
M	High	High	Good	Good
N	High	High	Poor	Good
K	Low	Low	Poor	Poor

Select with reasons an element which is likely to be:

(i) Copper metal (1mk)

.....

.....Silicon (iv)  
oxide (1mk)

.....

.....Potassium  
iodide (1mk)

.....

26. a) Write balanced chemical equations for reactions between chlorine and; (2 marks)

i) Concentrated sodium hydroxide

.....

ii) Dilute sodium hydroxide.

.....

b) State one observation made when a gas jar of moist hydrogen sulphide is inverted over a gas jar of dry chlorine gas. (1 mark)

.....

27.a) Hydrogen sulphide gas is bubbled through bromine water.

i) Give two observations made. (1 mark)

.....

.....

ii) Write an equation for the reaction that takes place. (1 mark)

.....

b) State the test for hydrogen sulphide gas. (1 mark)

28.(a) State Gay-Lussac's law. (1 mark)

b) When  $100\text{cm}^3$  of a gaseous hydrocarbon ( $\text{C}_x\text{H}_y$ ) burns in  $300\text{cm}^3$  of oxygen,  $200\text{cm}^3$  of carbon(IV)oxide and  $200\text{cm}^3$  of steam are formed.

Deduce the formula of the hydrocarbon. (2 marks)

# CROSS COUNTRY MOCKS

233/2  
CHEMISTRY  
PAPER 2  
(THEORY)  
TIME: 2HOURS.

1. 5 grammes of potassium chlorate were added to two boiling tubes A and B, 2 grammes of Copper (II)

Oxide was then added to B and then both tubes were heated from the same sandbath as shown below.

Glowing splints were lowered into the tubes, concurrently. During the heating, the splint in tube B relight earlier than tube A.

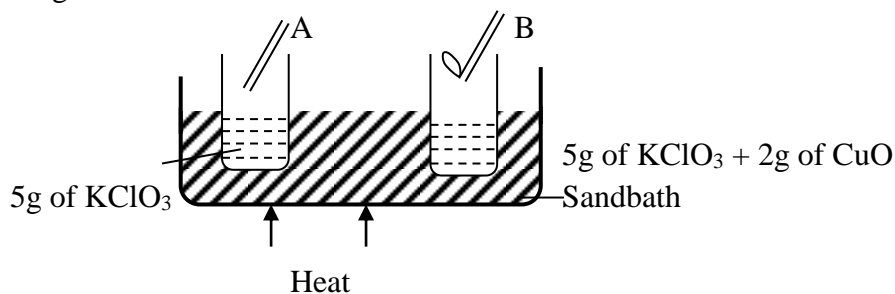

(a) Explain why the glowing splint in B relights earlier than earlier A. ( 2 marks)

.....

.....

.....

(b) The set up below was used to investigate a certain aspect about air.

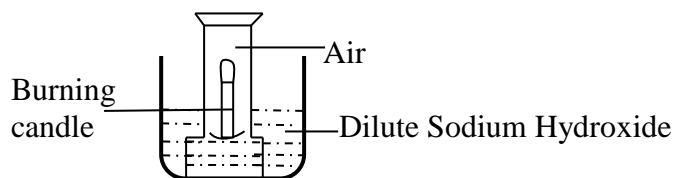

(i) Draw a diagram to illustrate how it would look like at the end of the experiment. (2marks)

(iii) Name two gases remaining at the end of the experiment.  
(2marks)

.....  
.....  
.....

(iv) State why dilute Sodium Hydroxide solution was used in the experiment.  
(1mark)

.....  
.....  
.....

(c) The diagram below shows how acidic and basic oxides fit into the general family of oxides.

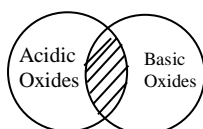

(i) State the name given to the type of oxides that would be placed in the shaded area. (1 mark)

.....  
.....

(ii) Write the formula of the two such oxides.

(1mark)

.....  
.....

2. (a) Two reagents that can be used to prepare chlorine gas are Potassium – Manganate (VII) and concentrated Hydrochloric acid.

(i) Write an equation for the reaction.

(1mark)

.....  
.....

.....  
.....  
(ii) Give the formula of another reagent that can be reacted with concentrated hydrochloric acid to produce chlorine gas.

(1mark)

.....  
.....  
(iii) Describe how chlorine gas could be dried in the laboratory.

(2marks)

.....  
.....  
(b) In an experiment, dry chlorine gas was reacted with aluminium as shown below.

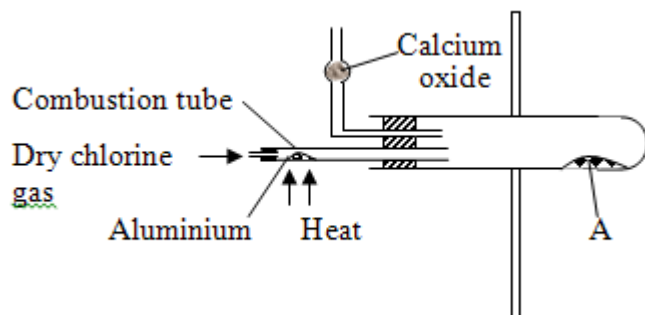

(i) Name substance A

(1mark)

.....  
.....  
(ii) Write an equation for the reaction that took place in the combustion tube.

.....  
.....  
(iii) When 0.84g of aluminium reacted completely with chlorine gas. Calculate the volume of chlorine gas



used. Molar gas volume is  $24\text{dm}^3$ ,  $A_1 = 27.0$   
(3marks)

(iv) Give a reason why calcium oxide is used in the setup  
(1mark)

3. The grid below represents part of the periodic table. Study it and answer the questions that follow.  
The

letters do not represent the actual symbols of the elements.

A								K
B	D						I	
			F		H			L
C	E						J	

(a) (i) Which letter represents a non metal that is least reactive?  
(1mark)

(

.....  
.....  
.....

(ii) Why are elements D and E referred to as alkali earth metals?  
(1mark)

.....  
.....  
.....

(b) How does the atomic radius of F and H compare?  
(2 marks)

( 2

.....  
.....  
.....

(c) Select two letters representing a pair of elements that would react most explosively. (1 mark)

.....  
.....  
.....

(d) Write an equation showing how D forms its ions. (1 mark)

.....  
.....  
.....

(e) Write the formulae of  
(i) Bromide of D (1/2 mark)

.....  
.....

(ii) Sulphate of C (1/2 mark)

.....  
.....

(f) What type of bonding exists between.  
(i) E and I (1/2 mark)

.....  
.....

(ii) G and I (1/2 mark)

.....  
.....  
(g) Explain why the melting point of J is higher than that of I ( 2 marks)

.....  
.....  
.....

4. (a) The diagram below was set up to study the products formed when a candle is burnt.

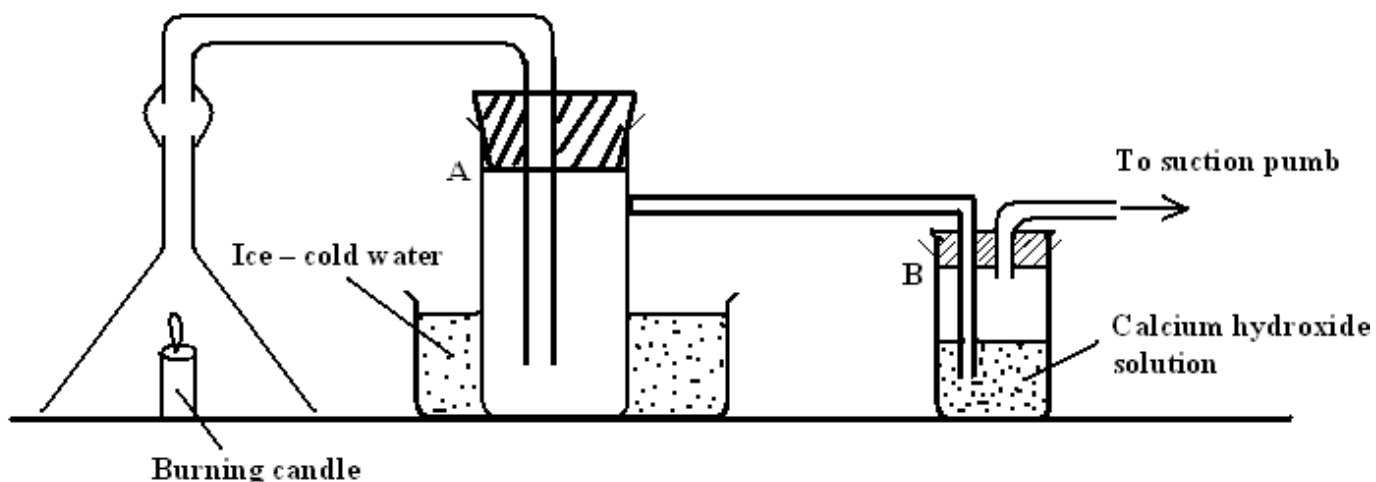

(i) State what would be observed in test tube B (1mark)

.....  
.....

(ii) State and explain what would be observed if the suction pump is switched off. (2marks)

.....  
.....

(iii) Describe how the identity of the product that is formed in test tube A can be confirmed. (2marks)

.....  
.....  
.....  
(b) 0.115g of Sodium metal was dropped in a trough full of water.

(i) State and explain what was observed than the production of a hissing sound.  
(2marks)

.....  
.....  
.....  
(ii) Calculate the volume of the gas produced at r.t.p (Na = 23, molar gas volume = 24 $\text{dcm}^3$  at r.t.p)

mark)

(2

.....  
.....  
.....  
(c) Dry hydrogen gas was passed over heated Copper (II) Oxide as shown below.

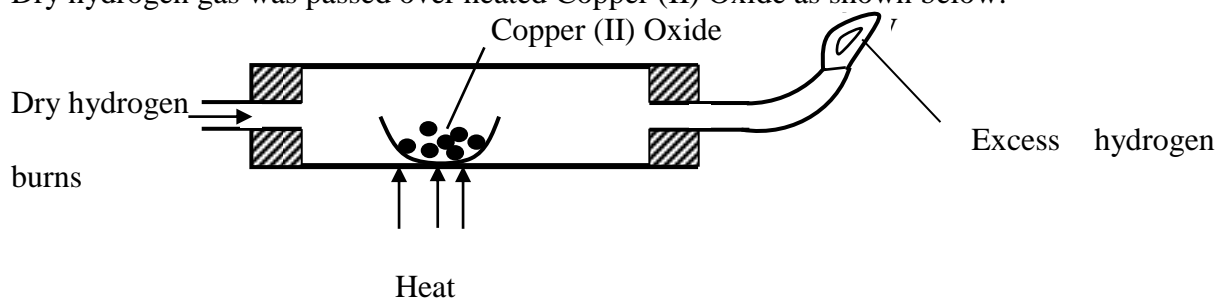

(d) (i) Write down the equation for the reaction that takes place in the combustion tube. ( 1 mark)

.....  
.....  
.....  
(ii) Name another gas that would play the same role as hydrogen if passed in the combustion tube

above.  
(1mark)

(iii) Describe how the purity of the product formed by the burning at V can be confirmed.  
(2marks)

.....

.....

5. (a) The diagram below was used to prepare a gas X in the laboratory. Study it and answer the questions that.

**Sodium ethanoate  
and soda lime**

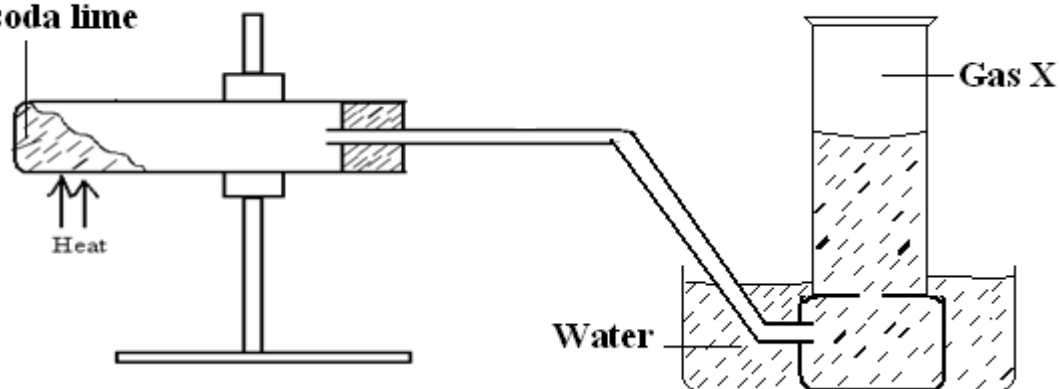

(i) Name gas X  
(1mark)

.....

(ii) Write an equation to show the production of gas X.  
(1mark)

.....

(b) Study the scheme diagram below and answer the questions that follow.

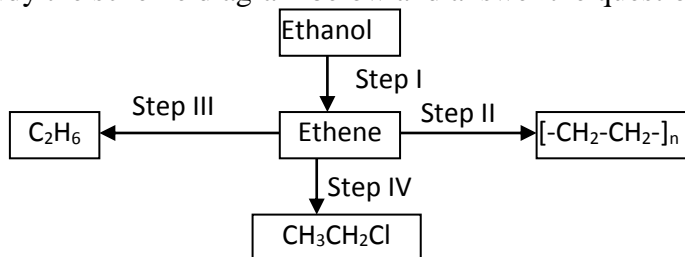

(i) Name the catalyst that is suitable to carry out the reaction in Step I.  
(1mark)

.....

.....

(ii) Name the process that takes place in Step II.

(1mark)

.....  
.....

(iii) State the conditions necessary for the reaction in Step III to occur.

(1mark)

.....  
.....

(iv) Write down the equation for the reaction that takes place in Step IV (1 mark)

.....  
.....

(c) Other than using burning, describe how you would distinguish between ethane and ethyne. (3marks)

.....  
.....  
.....  
.....

(d) (i) What are isomers? (1 mark)

.....  
.....

(ii) Draw and name all structures of all the isomers of the compound with molecular formula  $C_4H_8$  (3 marks)

.....  
.....  
.....  
.....  
.....

5. (a) The scheme below shows the industrial manufacture of sulphuric (VI) acid. Study it and answer the questions that follow.

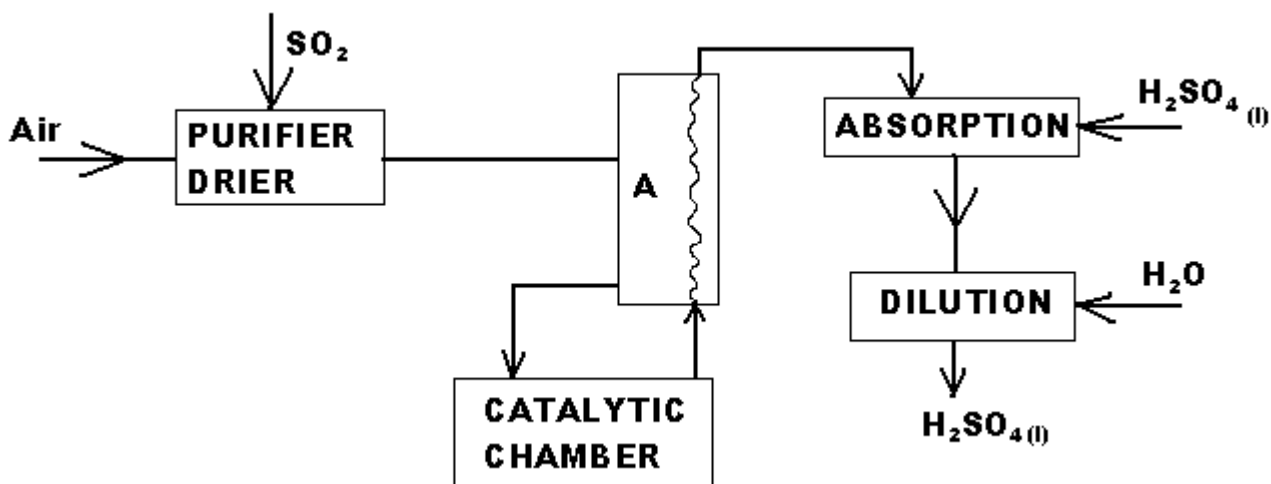

(i) Name the chamber A.  
(1mark)

.....  
.....

(ii) Explain why concentrated Sulphuric (VI) acid is used in the absorption chamber and not water.

(1mark)

.....  
.....

(iii) Write down the equation for the reaction that takes place at the absorption chamber  
(1mark)

.....  
.....

(iv) Name two catalysts that can be used in the catalytic chamber.  
(1mark)

.....  
.....  
.....

(b) Sulphuric (VI) acid is used in making fertilizers. What volume of ammonia gas will be required to

make 25kg of ammonium sulphate? (N = 14, H = 1.0, S = 32, O = 16.0

molar gas volume at r.t.p = 24.0dm<sup>3</sup>)

marks)

( 3

.....

.....  
.....  
.....

(c) State and explain what is observed when concentrated Sulphuric (VI) acid is placed in a test tube

containing.

(i) Cane sugar ( 2 marks)

.....  
.....  
.....  
.....

(ii) Sulphur and the mixture is warmed (2 marks)

.....  
.....  
.....  
.....

(iii) State two harmful effects Sulphur (IV) Oxide has on the environment. (1 mark)

.....  
.....  
.....  
.....

7. (i) What do you understand by the word allotropy? (1 mark)

.....  
.....

(ii) Diamond and graphite are naturally occurring allotropes of carbon. Explain why graphite conducts

electricity while diamond does not (1 mark)

.....  
.....  
.....



.....  
 (iii) Name one synthetic allotrope of carbon  
 (1mark)  
 .....

(b) The diagram below shows part of the set up that can be used to prepare Carbon (IV) Oxide in the Laboratory

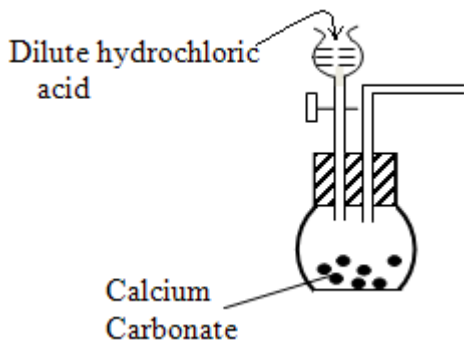

(i) Write down the equation for the reaction that takes place inside the flat bottomed flask. (1 mark)

.....  
 .....

(ii) Complete the diagram to show how a reasonably pure sample of the gas is collected. (3marks)

(c) The diagram below shows the main stages of the Soday process.

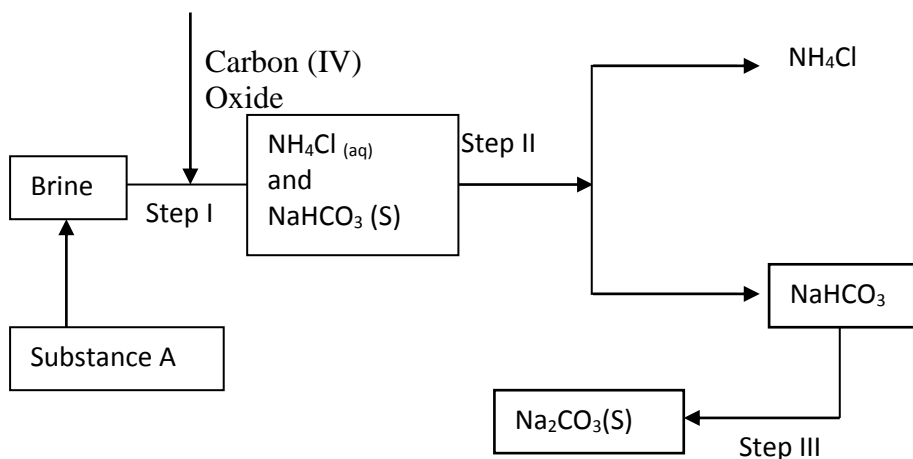

(i) Name the substance A (1 mark)

.....  
 .....

(ii) Write the equation for the reaction that takes place in Step III (1mark)

.....  
.....

(iii) Name the process in Step II (1mark)

.....  
.....

(c) A mixture contains 12.39g of both Sodium Hydrogen Carbonate and Sodium Carbonate. When the

mixture was heated to constant mass 1 dm<sup>3</sup> of Carbon (IV) Oxide was produced at r.t.p. Calculate the percentage composition of Sodium Carbonate in the mixture.

(2 marks)

(Na = 23, H = 1.0, C = 12.0, O = 16.0)

.....  
.....  
.....  
.....

# CROSS COUNTRY MOCKS

## COMPUTER STUDIES

### PAPER 1 (THEORY)

**SECTION A- Answer all the questions in this section**

1. What is a computer drive? (1 Mark)

.....  
.....  
.....

2. Mr. Osanoa computer technician in one of the schools used speech method to store students oral answers to an exam into a computer  
a) What is a speech input? (1 Mark)

.....  
.....

- b) State one advantage and one disadvantage of using this kind of input. (2 Marks)

.....  
.....

3. In reference to ALU, explain the meaning of logic operations and give an example of this processing operation. (2Marks)

.....  
.....  
.....

4. a) Identify the four types of storage media shown below (2Marks)



.....  
.....  
.....

- b) Compare the storage device (i) and (iii) above (1Mark)

.....  
.....

5. a) Define the term firewall (1 Mark).....

b) State three ways of ensuring efficient backup of data (2Marks)

6. a) Outline the three program control structures (1½Marks)

b) Give three types of selection construct (1½Marks)

c) Define the term encapsulation as applied in object oriented programming (2Marks)

7. i) What is Hypertext Mark Up Language? (1Mark)

ii) Why should a program be documented in each and every stage? (1Mark).....

8. A student was reading through a daily newspaper on different types of data communication media. As a computer student, how will you assist him define the term data communication media? (1Mark)

9. i) Differentiate between share level security and user level security as used in network security.

(2Marks).....

.....

.....

ii) What are the differences between Token ring topology and Ethernet topology? (2Marks)

.....

.....

10. i) Describe the term biometric analysis

(1Mark)

.....

11. Give two uses of spreadsheets in a government office concerned with carrying out national census

(2  
Marks)

.....

.....

12. i) A student at Sunshine secondary school was working with a computer using the windows operating system. After sometime he started experiencing the following problems.

- The computer failing to load the Operating system during the booting process
- The computer hangs now and then
- Abnormal restarting
- Display a blue screen with the message such as fatal exception error has occurred.

What could be the cause of the above problems? (2Marks)

.....

ii) A student was advised by the teacher to buy integrated software over separate software. What do you think could be the advantages of this?

(2Marks)

.....

13. a) What is a deadlock?  
(1Mark)

.....  
.....  
.....

b) Explain the term plug and play  
(1Mark).....

.....  
.....  
.....

c) Differentiate between a program file and a data file  
(1Mark).....

.....  
.....

14. i) State two factors you would consider when designing a file  
(1Mark)

.....  
.....  
.....

ii) List down three factors you need to consider during file conversion  
(3Marks).....

.....  
.....  
.....

15. State two limitations of language processing  
(2Marks)

.....  
.....  
.....

**SECTION B** (60 marks)

Answer question **16** and any other **three** questions from this section in the spaces provided.

16. (a) State the importance of the following in programming

(i) Assembler (1mk)

.....  
.....

(ii) Compiler (1mk)

.....  
.....

(b) A form four class sat for an exam in eight subjects. A student must get an average of 50% in all subjects in order to pass. A report is required that will show the name, marks obtained by each student per subject, the average mark and whether the student has passed or failed.

(i) **Write** a pseudocode used to solve this problem. (6mks)

(ii) Draw a flow chart for this report. (7mks)

17. (a)(i) State any THREE standard coding schemes used in computing and electronic systems.

(1½marks)

.....  
.....  
.....  
.....

(ii) Convert  $312_{10}$  using any TWO of the above mentioned coding schemes. (2 marks)

(iii) Using TWOs compliment, perform the following arithmetic leaving your answer in binary form

(2marks)

$$10_{10} - 13_{10}$$

(iii) Use one's compliment to solve the following sum:  $-18_{10}+12_{10}$

(2 ½ marks)

(b) (i) Explain the difference between the terms **browser** and a **search engine** with an example of each (3marks)

.....  
.....

(ii) What is the use of the **favorites** feature of an Internet browser?

(1 mark)

.....

(iii) What do the following abbreviations stand for?

(3 marks)

**i. URL**.....

**ii.**

**ISP**.....

**iii.**

**WWW**.....

18. (a) Differentiate between the following as used in word processing

(6marks)

(i) An **indent** and a **tab stop**

.....  
.....

(ii) **Margins** and **gutter**

.....  
.....



.....  
.....

(iii) **Footnotes and Endnotes**

.....  
.....  
.....

(b) A History teacher directed all students to present their work in double space format. Outline the procedure for double spacing a document. (3marks)

.....  
...  
.....  
...

(c) Owili, a form Four student, formatted a document to four columns. Explain how this was achieved in word processing (3marks)

.....  
...

(d) Ndwiga printed documents with paper layout as shown below.

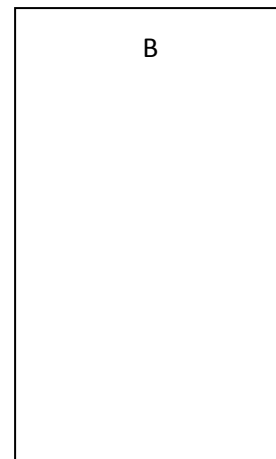
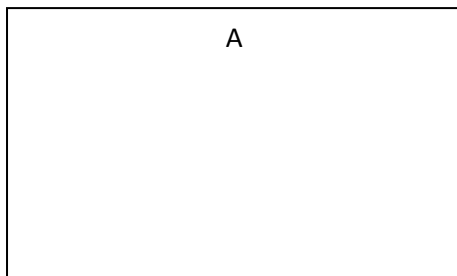

(i) Identify the layouts. (1mark)

.....  
...  
.....  
...

(ii) Explain when each layout should be applied (2marks)

.....  
...  
.....  
...  
.....  
...  
.....  
...

19. (a) Computer students visited KASSUJET TV station in the city and noticed that the News presenter in the studio was communicating in real time with other four reporters through a web cam and a microphone connected to a notebook PC nearby. The live images of the other reporters were projected on a white board mounted in the studio.

(i) Describe this type of communication. (2 marks)

.....  
...  
.....  
.....

(ii) State any TWO advantages and ONE disadvantage of this type of communication. (2 marks)

.....  
...  
.....  
...

(b) Currently there is a shift in technology towards digital from analog. State any THREE advantages of digital technology over analog technology. (3 marks)

.....  
...  
.....  
...

(c) (i) Documentation is usually not considered as a programming stage. Why is this so? (2 marks)

.....  
 ...

(ii) Differentiate between internal and external documentation. (2 marks)

.....  
 ...

(i) State THREE types of documentation that are available at the end of the programming project. (3 marks)

.....  
 ...

20. Martina Lotino went to the supermarket and bought the items shown in the picture of the spreadsheet given below:

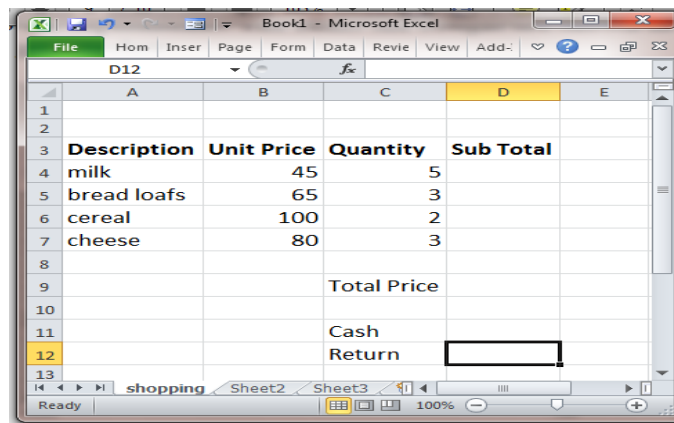

- (a.) (i) What is the name of the **active sheet**? (1 mark)
- (ii) By looking at the above picture, give the **reference of an active cell**. (1 mark)
- (iii) What function did the examiner use to **copy** the above picture on this examination paper? (1 mark)

.....  
 ...

(b) (i) A cell can contain a formula. **Name** the other TWO items which a cell can contain. (2 marks)

.....  
 ...  
 .....

(ii) Now, Julieta , a new employee, has just joined the company and does not know the difference between a formula and a function. You are required to explain this to her in the space provided below. Support your explanation with an example of each. (4 marks)

Formula:.....

...

Example:.....

...

Function:.....

...

Example:

.....

(c) (i) Write the **formulae** that must be typed in the following two cells: **D5, D7** (2 marks)

.....

.....

.....

.....

(ii) Write the function that must be typed in cell **D9**: (2 marks)

.....

.....

(iii) The bill total in cell D9 amounts to Ksh.860 Martina has a Ksh.1000 note. Write the formula that calculates the change in **D12**. (2 marks)

.....

.....

# **CROSS COUNTRY MOCKS**

## **Kenya Certificate of Secondary Education**

**313/1**

### **Christian Religious Education**

#### **Paper 1**

1. (a) From the biblical accounts of creation show why mankind was a very valuable part of God's creation. (6 marks)  
(b) Explain the Traditional African view of creation. (7marks)  
(c) Outline **seven** ways in which God has continued to carry out his salvation for mankind since the fall of man. (7 marks)
2. (a) Give the significance of God's covenant with Abraham. (6 marks)  
(b) Give **four** differences between the traditional Africa and Jewish circumcision practices. (8 marks)  
(c) What values do we learn from the call of Abraham? (6 marks)
3. (a) State **seven** theophany of the power of God as experienced in the story of prophet Elijah. (7 marks)  
(b) Explain **four** factors which made it difficult for Elijah to stop idolatry. (8 marks)  
(c) What problems are encountered by Christian missionaries in their work today? (5 marks)
4. (a) Give **six** characteristics of false prophets in the Old Testament. (6 marks)  
(b) Explain why Israel would face judgment according to the teachings of prophet Amos. (8 marks)  
(c) Outline the concept of the Day of the Lord according to Prophet Amos. (6 marks)
5. (a) Explain **five** symbolic actions that show that Prophet Jeremiah was both a prophet of doom and hope. (10 marks)  
(b) Identify the problems Nehemiah faced as a governor of Judah. (5 marks)  
(c) What **five** lessons do Christians learn from the leadership of Nehemiah? (5 marks)
6. (a) Give **seven** reasons why the Kinship system was an important feature in Traditional African society (7 marks)  
(b) Show how marriage was formalized in Traditional African Society. (6 marks)  
(c) State **seven** factors that promote social and economic change in Traditional Africa Society today. (7 marks)

# **CROSS COUNTRY EXAMS**

## **KENYA CERTIFICATE OF SECONDARY EDUCATION**

**313/2**

**C.R.E**

**PAPER 2**

1. (a) With reference to specific Old Testament prophets, outline eight prophecies about Messiah. (8mks)
- (b) Identify seven similarities between the annunciation of the birth of John and that of Jesus. (7mks)
- (c) What lessons do Christians learn from the teachings of John the Baptist? (5mks)
2. (a) Give seven reasons why Jesus used parables in his teachings. (7mks)
- (b) Outline seven importance of the transfiguration of Jesus to his ministry. (7mks)
- (c) Identify six lessons Christians learn from the call of the first disciples of Jesus. (6mks)
3. (a) Give six signs of eschatology as taught by Jesus. (6mks)
- (b) With reference to Luke 19:28-40, relate the triumphant entry of Jesus into Jerusalem. (9mks)
- (c) Give five reasons why Christians find it difficult to pray. (5mks)
4. (a) With reference to 1 Cor. 12:12-27, show how Paul's teaching on unity of believers is illustrated in the image "body of Christ" (8mks)
- (b) Identify six areas of cooperation between the church and the state in Kenya. (6mks)
- (c) Give six ways in which the Holy Spirit manifests himself among Christians today. (6mks)
5. (a) Explain eight Christian teachings on human sexuality. (8mks)
- (b) State seven effects of alcoholism on a person's career. (7mks)
- (c) Identify five ways in which Christians can assist people who are living with HIV/AIDs in the

society. (5mks)

6. (a) Explain seven ways in which money economy has undermined the principles of Christian living.

(7mks)

(b) Outline the Christian view on organ transplant. (7mks)

(c) State six ways in which Christians put their wealth to good use. (6mks)

# **CROSS COUNTRY EXAMS**

## **KENYA CERTIFICATE OF SECONDARY SCHOOL EDUCATION**

### **ENGLISH**

#### **Paper 1**

1. You are the secretary of Umoja Faith Church Youth Group. The group is planning to hold a meeting on 16<sup>th</sup> August 2014 whose main agenda will be the Mission Outreach and initiating income generating activities. The constitution stipulates that there must be a 21-day notification of the meeting.
- i) Write a notice of the meeting that will be sent to the members. 6 marks
  - ii) During the meeting, 8 members were present, 3 including the treasurer sent apologies and the whereabouts of 2 members were unknown. The youth pastor attended the meeting. Apart from the main issues, members raised some matters from the previous meeting. There were also some personal issues raised by some members.  
Write down the minutes of the meeting.

2. *Read the passage below and complete each blank space with an appropriate word 10 marks*

Citizens used to i)..... that political leaders would observe the principles of good governance simply ii).....they were expected to. iii).....; it appears most leaders on the continent have replaced integrity with reckless impunity that has iv)..... Africa in chaos. v).....office are also supposed to be vi)..... to the people that entrusted them with them the vii).....of leading them. viii)....., the political elite in the continent see people as a means to an end. In many countries these days, Kenya included, politics has become the easiest way to make money. Electioneering is seen as an ix).....with extremely lucrative returns when campaign loyalties are x).....with appointments in the government of the day.

3. *a) Read the following Ankole song and answer the questions that follow.*

Suck and I hide you, my gentle one  
and I hide you, my beloved  
that the hunt was at Buganga  
hunt was at Ngarama

Suck  
I dreamt  
I dream that the

Where, oh where, shall I put, my little baby?  
oh where, shall I put you, my lovely little lips?  
in a clump of grass, my gentle one

Where,  
If I put you  
The hunters' rough



dog will come sniffing around  
club tears up the back

The hunters' thick

Suck and I hide you, gentle one  
and I hide you, for whom the drum sounds

Suck

Where, oh where, shall I put you, my lovely little lips?  
oh where, shall I put you, my beloved?

Where,

If I put you by the wayside, gentle one  
will take you with them, my beloved  
anthill, my little baby  
their nest, lovely little lips

Passers-by  
If I put you in an  
The ants will enclose you in  
Suck and I hide you, little baby  
Suck and I hide you, my gentle one

When I am dead and gone, gentle one  
on little blades of grass like cow, my beloved  
wash them down with a little water, my little baby  
raises orphans, you for whom the drum sounds  
die, my little baby  
things will be ours to enjoy, you for whom the drum sounds

Feed  
And  
That's what  
If I do not  
Good

i) Identify aspects of oral performance that make this song easy to remember? 2mks

.....  
.....

ii) In what ways would this song be made interesting to listen to? 2mks

.....  
.....

iii) How would you perform the last two lines of the above song? 2mks

.....  
.....

b) Study the genre below and answer the questions that follow

**I have a wife everyone she bears has a bead**

i) Identify the genre under which the above item falls. 1mk

.....

ii) Assuming you were to perform this genre, what will you do before the presentation? 1mk

.....

iii) How will (ii) above assist you as a presenter? 1mk

.....

c) Identify the silent letters in the words below 3mks

- i) Shepherd .....
- ii) Rendezvous .....
- iii) Epistle .....

d) Write another word that has the same pronunciation as the following words 3mks

- i) Mark .....
- ii) Broach .....
- iii) Proof .....

e) Underline the stressed the syllables in the highlighted words 2mks

- i) We have to *relocate* these people
- ii) The security officer will *punish* you if you come late.

f) Indicate whether the following sentences have a falling or a rising intonation. 2mks

- i) A stitch in time saves nine
- ii) Do you like tomatoes or not.

g) Jaramba's son, Mariapa, was really enthusiastic to go for a party with his friends at Carnivore. He had been invited to a friend's birthday party. He had to get permission from the father first in order to attend. However, Mariapa failed to convince his father because of his approach and language. What could have been the weaknesses in his negotiation skills? 5mks

.....

.....

.....

.....

.....

h) Read the conversation below between Audrey, a student, and the school secretary then answer the questions that follow. 6mks

Audrey: Hallo. Good morning.

Secretary: Hallo. Who is on the line and what do you want?

Audrey: I am a Form 4Y student and I have been away from school for three days now. May I speak to the Principal?

Secretary: The Principal is not in the office now.

Audrey: Could I please leave a message for him?

Secretary: Oh, please, don't you have his cellphone number?

Audrey: No madam, since it is official, kindly take down the...

Secretary: Excuse me, young girl, I am too busy for this idle chat.

Audrey: I am sorry but it is very urgent, madam.

Secretary: *(without a pen or paper)* Go ahead and you better be quick.

Audrey: Thanks for the attention

i) *Identify the weaknesses in the secretary's telephone conversation skills.* 3mks

.....  
.....  
.....

ii) *What should she do to improve on this?* 3mks

.....  
.....  
.....  
.....

**WHATSAPP 0705525657 FOR PAPER 2&3**

# **CROSS COUNTRY EXAMS**

## **The Kenya Certificate of Secondary Education**

### **GEOGRAPHY PAPER 1**

#### **SECTION A**

*Answer all questions in this section*

1. (a) What do you understand by the following ?
  - (i) Micro climate (2mks)
  - (ii) Greenhouse effects (2mks)
- (b) State two conditions necessary for formation of fog. (2mks)
2. (a) Name two types of tectonic plates (2mks)
- (b) State two effects of earthquakes on the human environment (2mks)
3. (a) State three factors that influence the occurrence of underground water. (3mks)
- (b) Give two processes involved in the formation of Karst scenery. (2mks)
4. The diagram below represents the solar system. Use it to answer question (a)

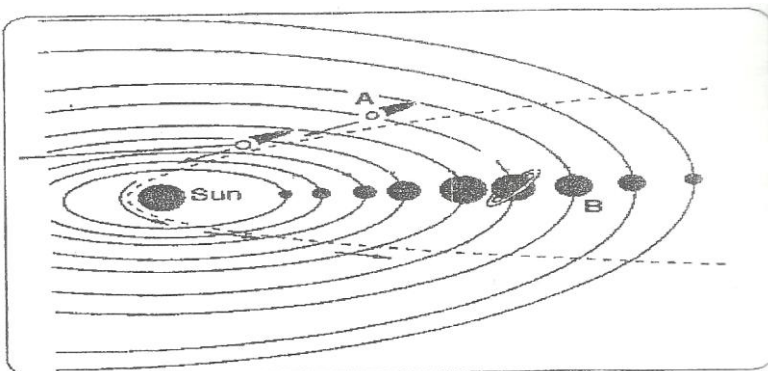

- a) Name the heavenly bodies labeled A and B (2mks)
- b) Give two characteristics of Jupiter planet. (2mks)
5. (a) Identify categories of desert surfaces (3mks)
- (b) State three reasons why wind is an active agent of erosion in hot deserts. (3mks)

SECTION B

Answer question 6 and any other two questions from this section

6. Study the map of Kitale (sheet 75/3, Scale 1:50,000) provided and answer the questions that follow.
- (a) (i) Name the features found in grid reference 395328. (1mk)
  - (ii) Name two drainage features other than rivers shown in the mapped area (2mks)
  - (b) (i) MEASURE THE length of the all- weather loose surface road C 638 from its junction with the dry weather road C 640 at grid square 4314 to Northing 11. Give your answer in Kilometres.
  - (ii) Calculate the area of Kapolet Forest Area in square kilometers. (2mks)
  - (c) (i) Give the approximate position of Kitale Township in latitude and longitude (2mks)
  - (ii) What is the general direction of flow of River Noigameger? (2mks)
  - (d) (i) Draw a frame of dimensions 14cm by 10cm to represent the area bound by the eastings 23 and 30 and the northings 11 and 16. (1mk)
  - (ii) On the frame, mark and name:
    - railway line:
    - Papyrus swamp;
    - All weather loose surface road C 641. (3mks)
  - (iii) State the scale of the sketch drawn in (b)(i) above. (1mk)
  - (e) Students from a school in grid square 2614 conducted a field study of Kitale township.
    - (i) Citing evidence from the map, state three functions of Kitale Township they are likely to identify. (3mks)
    - (ii) State two physical problems they could have encountered during the study. (2mks)
  - (f) Describe the vegetation of the area covered by the mapped area. (4mks)

7. (a) (i) Define the term lake (2mks)
- (ii) Name three sources of water in the lakes other than rivers. (3mks)
- (b) (i) State three reasons why some lakes may contain fresh water (3mks)
- (ii) Give two examples of lakes formed due to vulcanicity in East Africa. (2mks)
- (c) The map below shows some lakes and rivers in Kenya. Study it and use it to answer the questions that follow.

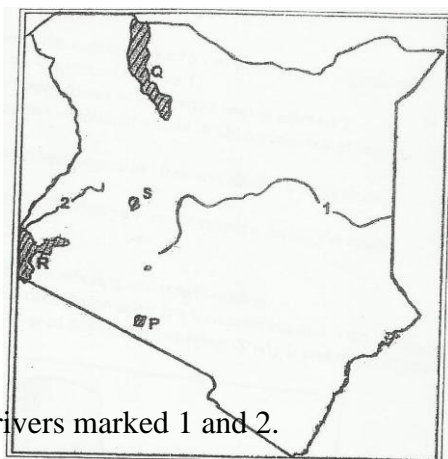

- (i) Name the rivers marked 1 and 2. (2mks)

(ii) Identify and name the lakes marked P, Q, S.  
(3mks)

(iii) Briefly explain how the lake R was formed.  
(5mks)

(d) State five significances of lakes. (5mks)

8. (a) Differentiate between natural vegetation and derived vegetation. (2mks)

(b) (i) Outline three characteristics of tropical grasslands (3mks)

(ii) Explain three factors that have led to a decline of the natural grasslands in Kenya (6mks)

(c) The diagram below shows vegetation succession on a mountain in the tropics. Study and use it to answer the questions that follow.

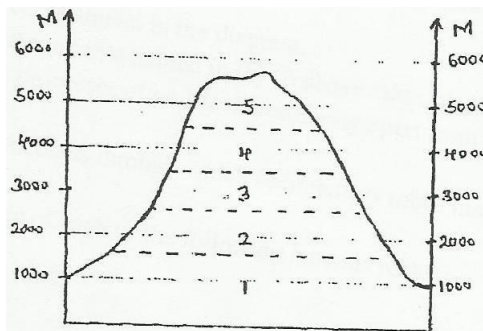

(i) State two reasons why the line region marked 5 has poor/scanty vegetation (2mks)

(ii) Give three uses of vegetation region marked 1 (3mks)

(iii) Name two species of tree found in vegetation region marked 2. (2mks)

(d) Students of Bunyore Girls intend to conduct a field study on vegetation in an arid and semi-arid land in Kenya.

(i) Explain two adaptations of desert vegetation they are likely to observe during the study. (4mks)

(ii) State three methods of data collection you would employ during the study. (3mks)

9. (a) (i) Give two differences between weathering and mass wasting. (2mks)

(ii) Name two other processes of denudation apart from weathering and mass wasting. (2mks)

(b) The diagram below shows a process of physical weathering. Study it and use it to answer the questions that follow.

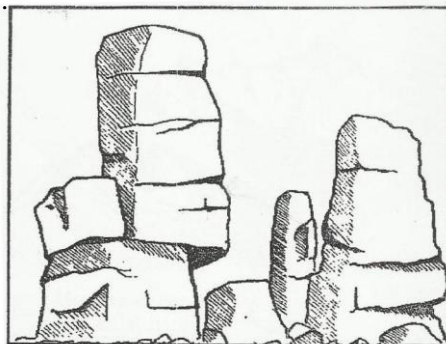

(i) Identify the process shown in the diagram (1mk)

(ii) Describe how the process named in (b) (i) above takes place. (4mks)

(iii) Give two other processes of physical weathering apart from the one named in (b) (i) above.

(2mks)

(c) (i) Describe two processes through which sedimentary rocks may change into metamorphic rocks. (4mks)

(ii) Give two examples of each of the following igneous rocks;

- Plutonic
- Hypabyssal
- Volcanic

(3mks)

(d) Suppose members of your class were to conduct a field study on rocks within the vicinity of school.

(i) Name two secondary sources of information you would use to prepare for the study. (2mks)

(ii) State three activities you would carry out during the study (3mks)

(iii) State two importance of rocks you are likely to find out during the study. (2mks)

10. (a) Differentiate between a valley glacier and an ice sheet. (2mks)

(b) Briefly describe how the ice moves through the following processes.

(i) Basal slip; (3mks)

(ii) Extrusion flow. (3mks)

(c) State two processes through which glaciers erode (2mks)

(d) The diagram below shows various features that result from glacial erosion. Use it to answer the questions (i)

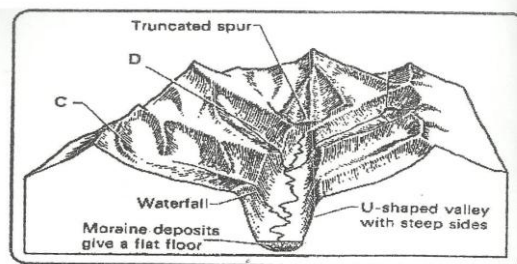

(i) Identify and name the features labeled C and D. (2mks)

(ii) Describe the formation of a cirque. (4mks)

(e) With the aid of clear labeled diagram(s), name three types of moraines. (3mks)

(f) Explain three benefits of glaciations to human activities. (6mks)

# CROSS COUNTRY EXAMS

## GEOGRAPHY PAPER 2

### SECTION A.

*Answer all the questions in section A*

**Q1.(a)** What is wildlife? (1mark)

(b) List **two** physical problems affecting wildlife in Kenya (2marks)

(c) State the measures being undertaken in East African to manage wildlife (3marks)

**Q2 (a)** Name **two** horticultural crops grown in Kenya (2marks)

(b) State **three** human factors favouring horticultural farming in Kenya. (3marks)

**Q3.(a)** Name **two** exotic breeds of cattle reared in commercial ranches in Kenya (2mark)

(b) State **three** environmental conditions which favour commercial beef farming  
in Kenya. (3marks)

**Q4.(a)** Name **two** indigenous softwood tree species found in Kenya. (2marks)

(b) State **three** characteristics of temperate hardwood forests. (3marks)

**Q5.(a)** What is energy crisis? (2marks)

(b) State **three** solutions to energy crisis in the world (3marks)



**SECTION B:**

Answer question six (6) and any other two from the remaining questions

Q6. Comparative line graph

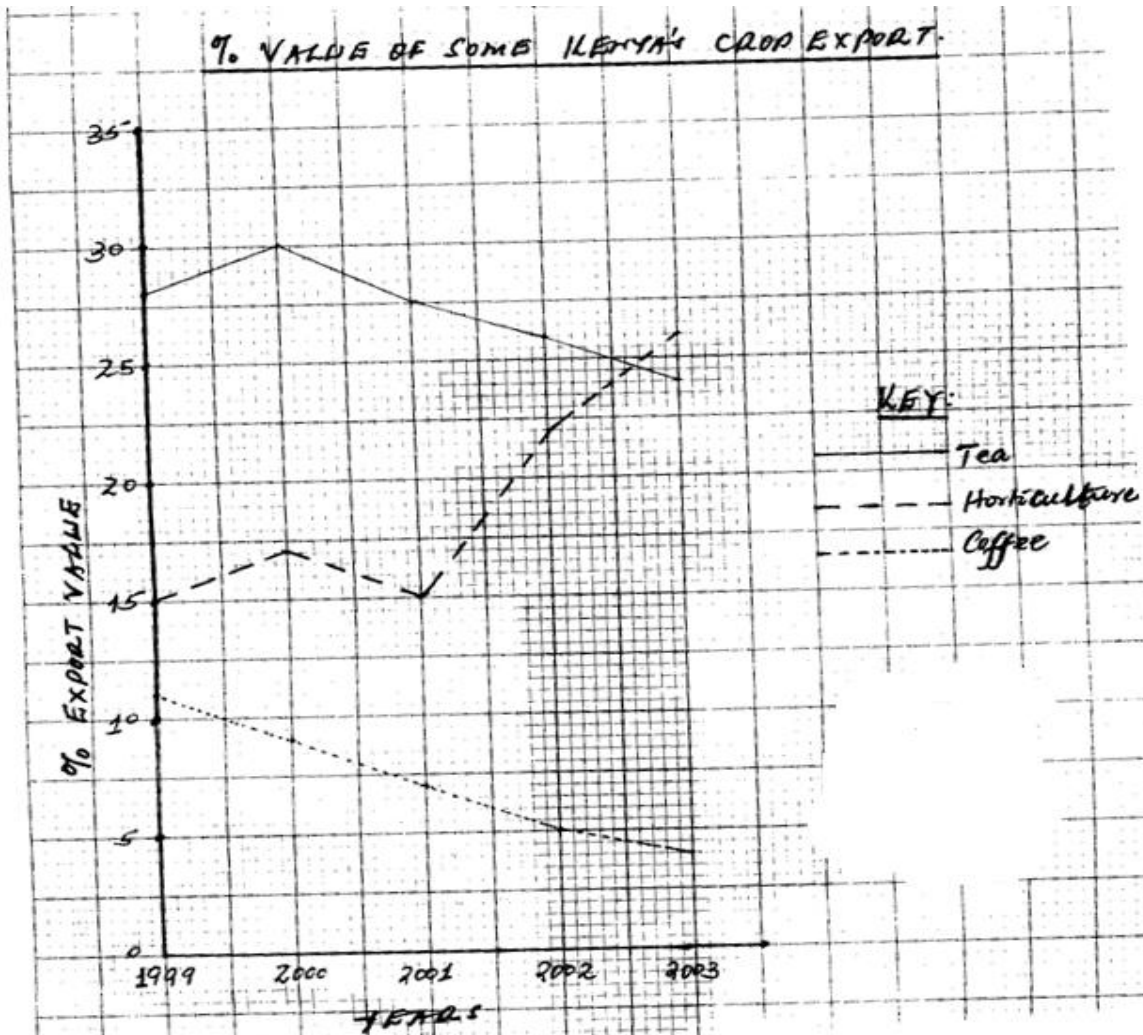

- (a) What was the percentage difference between value exports of tea and horticulture in the year 2000 (1mark)
- (b) Explain **three** factors which may have led to the increased export earnings from horticulture between 1999-2003 (6marks)

(c) Give **two** advantages of using comparative line graph to represent statistical data **(2marks)**

(d) (i) Describe **four** physical factors favouring cocoa growing in Ghana **(8marks)**

(ii) Outline the stages of Cocoa growing in Ghana from harvesting to Marketing **(5marks)**

(iii) State three physical problems facing cocoa farming in Ghana **(3marks)**

**Q7.** (a) (i) Differentiate between land reclamation and land rehabilitation **(2marks)**

(ii) Name **two** methods of land rehabilitation in Kenya. **(2marks)**

(b) The map below shows major irrigation schemes in Kenya. Used to answer the questions that follow

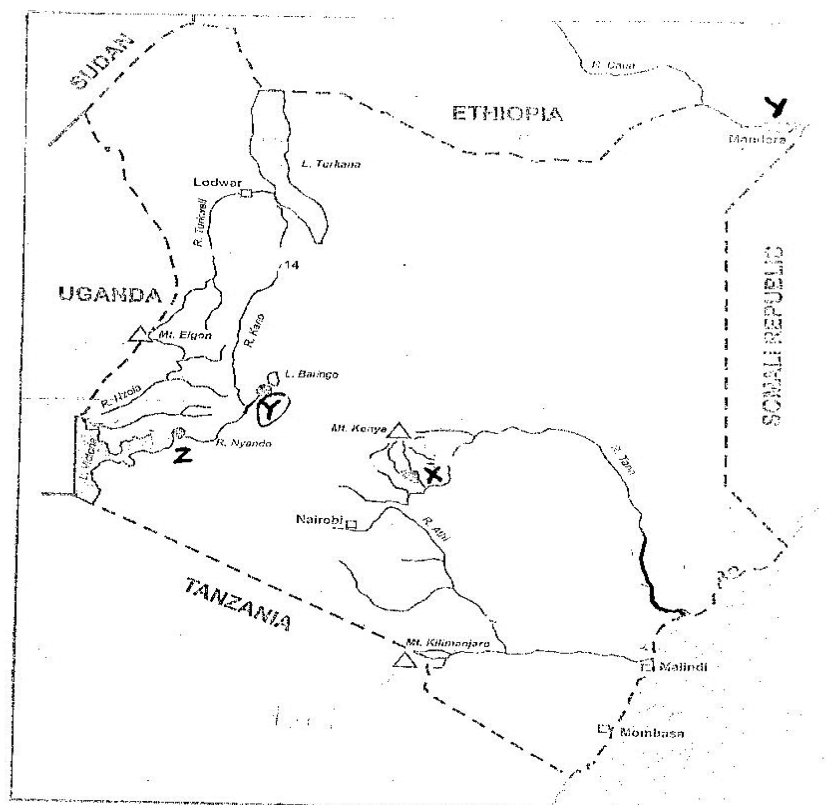

(i) Name the irrigation schemes marked X,Y & Z (3marks)

(c) (i) Name **two** crops grown in Perkerra irrigation scheme (2marks)

(ii) Explain **three** physical factors favouring the establishment of perkerra  
Irrigation scheme. (6marks)

(iii) State **two** solutions to the problems encountered in the scheme (2marks)

(d) Explain **four** significance of irrigation farming in Kenya. (8marks)

**Q8.** (a) State **three** ways in which minerals occur. (3marks)

(b) Explain how the following factors influence mining:

- Mode of exploitation (2marks)
- Transport system. (2marks)

(c) Use the map of East Africa below to answer questions

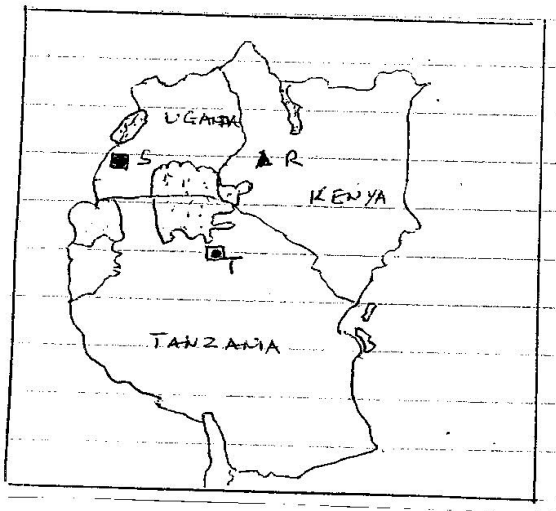

(i) Name the minerals found in the areas marked R, S and T. (3marks)

(ii) Describe deep shaft mining method (6marks)

(d) (i) Name **two** areas where diamond is mined in South Africa. (2marks)

(ii) Outline the processing of diamond in South Africa. (5marks)

(i) State **two** human problems facing diamond mining in South Africa. (2marks)

**Q9.** (a) (i) Define fishing (1mark)

(ii) State **three** factors favouring fishing in L. Victoria (3marks)

(iii) Name **two** fish species along the Kenya Coast (2marks)

(b) Use the Map of the N-W Pacific fishing ground to answer the questions that follow:

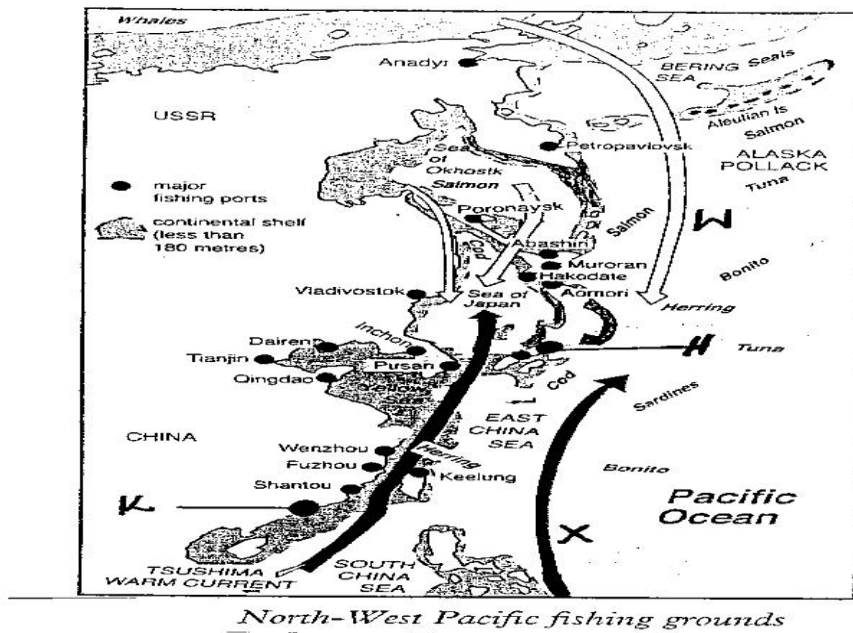

(i) Identify the ocean current marked W and X (2marks)

(ii) Name the major ports marked **H** and **K** (2marks)

(iii) Describe how drifting method is employed in marine fishing (5marks)

(c) Compare fishing in Kenya and Japan under the following sub-headings:

(i) Technology (2marks)

(ii) Nature of the coastline (2marks)

(iii) Research (2marks)

(d) Give **four** conservation measures of fisheries in Kenya (4marks)

**Q10.(a)** (i) Define the term energy. (2marks)

(ii) Identify the type of energy from the following sources. (3marks)

- Sun
- Uranium
- Wind

(b) (i) Explain **three** physical factors that have influenced the location of

Owen Falls hydro-electric power project in Uganda. (6marks)

(ii) Explain **two** benefits of hydro-electric power project to the economies of East African countries. (4marks)

(iii) A part from Owen falls dams, name **two** other Hydro-electric power projects in Uganda. (2marks)

(c) A Mokasa geography class intends to carry out a field study at Olkaria Geothermal Power Plant.

(i) State **two** objectives of the study (2marks)

(ii) Give **three** reasons why a pre-visit would be necessary or their study. (3marks)

(iii) What **three** follow-up activities are they likely to engage in after the Study? (3marks)

# **CROSS COUNTRY EXAMS**

**KENYA CERTIFICATE OF SECONDARY EDUCATION (K.C.S.E)**

**311/1**

**HISTORY & GOVERNMENT**

**PAPER 1**

**SECTION A (25 MARKS)**

*Answer all questions in this section*

1. Name one branch of History (1 mark)
2. Give the name of the council of elders among the Agikuyu (1 mark)
3. State the first settlement area of the Luo during their migration from Sudan (1 mark)
4. Give two reasons why independent churches were established in Kenya during the colonial period (2 marks)
5. State one reason why missionaries came to East Africa (1 mark)
6. Identify the constitutional change that increased the number of African members to the Legislative council in Kenya in 1987 (1 mark)
7. Identify one Asian who took part in the struggle for independence in Kenya (1 mark)
8. State one feature of the constitution which was drawn during the second Lancaster house conference in 1962 (2 marks)
9. Give two reasons why Africans were not given academic education during the colonial period (2 marks)
10. Identify two functions of the Attorney General in Kenya (2 marks)
11. State two advantages of the promotion of culture in Kenya (2 marks)
12. Identify two conditions that one must fulfill in order to be eligible for election as the president in Kenya (2 marks)
13. State two roles of the Judiciary in Kenya (2 marks)

14. Give two roles played by the ruling party in Kenya (2 marks)
15. Give two symbols of National unity in Kenya (2 marks)
16. Give one reason that can make a registered person loose citizenship in Kenya (mark)
17. Give one type of Human rights (1 mark)

**SECTION B (45 MARKS)**

*Answer any THREE questions in this section in the answer sheet provided.*

**SECTION B (45 MARKS)**

Attempt any **THREE** questions from this section.

18. (a) Outline **five** reasons for the migration of the Luo from their original homeland. (5 marks)
- (b) Describe the political organization of the Somali during the pre-colonial period. (10 marks)
19. (a) State **three** political reasons why the British were interested in Kenya. (3 marks)
- (b) Explain **six** problems faced by the Imperial British East Africa Company in Kenya. (12 marks)

20. (a) Identify **three** crops grown by the White settlers in colonial Kenya. (3 marks)
- (b) Explain **six** negative effects of urbanization in colonial Kenya. (12 marks)
21. (a) Outline **three** achievements of the Kenya African Union. (3 marks)
- (b) Describe **six** effects of Mau Mau. (12 marks)

**SECTION C (30 MARKS)**

*Answer any TWO questions in this section in the answer sheet provided.*

22. (a) Give three ways by which one can become a Kenyan citizen by registration (3 marks)
- (b) Explain **six** factors that promote national integration in Kenya (12 mks)
23. (a) State **three** characteristics of a good constitution (3 marks)
- (b) Describe the advantages of Democracy (12 mks)
24. (a) What is the composition of the cabinet in Kenya (3 marks)
- (b) Explain **six** functions of the Cabinet Secretaries (12 mks)



# **CROSS COUNTRY EXAMS**

## **HISTORY AND GOVERNMENT**

### **Paper 2**

#### ***Section A (25 marks)***

***Answer all questions in this section in the answer booklet provided***

1. Identify **two** unwritten sources of information in History and Government. (2marks)
2. Mention **one** chemical dating method used by the archeologists. (1mark)
3. State **two** economic practices of Homo sapiens (2 marks)
4. Name **one** river that was associated with early agriculture in Mesopotamia. (1 mark)
5. Why is the camel referred to as ‘the ship of the desert’? (2 marks)
6. What was the **major** development in Transport which promoted early Agriculture in Mesopotamia (1mark)
7. Identify **two** forms of Messages that could be relayed by the use of drum beats in Ancient times. (2 marks)
8. Mention **one** disadvantage of using coal as a source of energy. (1mark)
9. Give **two** consequences of urbanization in Johannesburg. (2 marks)
10. What was the **most** important symbol of unity among the Asante? (1mark)
11. State **one** way through which the European maintained peace among themselves during the partition of African (2marks)
12. Apart from Nigeria and Ghana, name one other West African country which was ruled by Britain (1mark)
13. State **two** conditions that one had to fulfill to become assimilated to French West Africa (2 marks)
14. What was the response of white racist government to African nationalists’ demands in South Africa? (1mark)
15. State **two** reasons why Adolf Hitler of Germany was interested in Russia at the beginning of Second World War. (2marks)

16. State the **main** function of the International court of justice. (1mark)
17. Give **one** challenge that has faced the Common Market of Eastern and Southern Africa (COMESA) since its inception (1mark)

*Section B (45 marks)*

*Answer any three questions from this section in the answer booklet provided*

18. (a) Outline **three** physical characteristics of Egyptian ape. (3 marks)
- (b) Describe the culture of the early man during the Old Stone Age. (12 marks)
19. (a) Identify **three** inventions in Britain which contributed to agrarian revolution. (3 marks)
- (b) Explain **six** results of early agriculture in Egypt. (12 marks)
20. (a) Give **five** difficulties faced by the Trans-Saharan traders. (5 marks)
- (b) Explain **five** factors which contributed to the decline of the Trans-Saharan trade. (10 marks)
21. (a) Identify **three** challenges faced by Samori Toure after he established his second empire. (3 marks)
- (b) Explain **six** factors that enabled the Franco-Mandinka war to be protracted. (12 marks)

*Section C (30 marks)*

*Answer any TWO questions from this section in the answer booklet provided*

22. (a) State **five** factors that contributed to the rise and expansion of the Asante Kingdom by the 19<sup>th</sup> century. (5 marks)
- (b) Describe the political organization of the Asante Empire in the pre-colonial period. (10 marks)
23. (a) Give **three** reasons why the Pan African movement was not active in the African Continent before 1945. (3 marks)
- (b) Discuss **six** ways in which member states benefit from the Commonwealth of Nations. (12 marks)
24. (a) State **five** objectives of the Economic community of West African States (ECOWAS). (5 marks)
- (b) Explain **five** achievements ECOWAS has made since its formation in 1975. (1

# CROSS COUNTRY EXAMS

HOMESCIENCE  
PAPER 1  
(THEORY)  
SMARCH/APRIL 2015

**SECTION A (40 MARKS)**  
*Attempt all questions in this section.*

1. Define the following terms as used in Home-management.

i) Budget

(2mks)

.....  
.....  
.....

ii) Wear and tear

(2mks)

.....  
.....  
.....

2. List down **two** methods of identifying silk.

(2mks)

.....  
.....  
.....

3. List down **four** factors which influence a cooking method

(4mks)

.....  
.....  
.....  
.....  
.....

4. Mention **three** causes of poor sanitation

(3mks)

.....  
.....  
.....  
.....

5. Laundry equipment can be classified into **four** categories. Identify these categories.

(4mks)

.....  
.....  
.....  
.....  
.....

6. State **five** reasons for cooking food

(5mks)

.....  
.....  
.....  
.....  
.....  
.....

7. Give **two** deficiency diseases common in children

(2mks)

.....  
.....  
.....

8. List down **two** self-neatening seams

(1mk)

.....  
.....  
.....

9. List **four** methods of transferring pattern markings onto a fabric

(2mks)

.....  
.....  
.....  
.....  
.....

10. State **five** advantages of a traditional hut design

(2mks)

.....  
.....  
.....  
.....  
.....  
.....

11. State **four** precautions to take to avoid fire accidents in the kitchen.

(2mks)

.....  
.....  
.....  
.....  
.....

12. List **four** methods of finishing an open seam

(2mks)

.....  
.....  
.....  
.....  
.....

13. Give **one** way of disinfecting bath towels

(2mks)

.....  
.....  
.....

14. Identify **four** disadvantages of buying a house  
(2mks)

.....  
.....  
.....  
.....  
.....

**SECTION B (20MARKS)**

*Compulsory question*

15. Your uncle has asked you to assist in carrying out some household chores

a) Outline the procedure for dry cleaning his polyester tie  
(8mks)

.....  
.....  
.....  
.....  
.....  
.....  
.....  
.....  
.....  
.....  
.....  
.....  
.....  
.....  
.....  
.....  
.....  
.....  
.....  
.....  
.....

b) Explain how to launder his cotton handkerchief  
(7mks)

.....

.....

.....

.....

.....

.....

.....

.....

.....

.....

.....

.....

.....

c) Describe the procedure of thorough cleaning a discoloured melamine cup.  
(5mks)

.....

.....

.....

.....

.....

.....

.....

.....

.....

.....

**SECTION C (40MARKS)**

*Answer any two questions from this section. Each question carries 20 marks.*

- 16. a) Explain **four** qualities of a good ironing board  
(8mks)
- b) Giving **two** examples in each case, list 2 types of stain removers. (4mks)
- d) Explain **four** rules to observe when removing stains  
(8mks)

17. Fill in the blanks indicated by the letters a – j in the table shown below.

Vitamin	Scientific	Nutritional
name	disorder	

	Niacin/nicotinic acid	(a)
(b)	Thiamine	(c)
Vitamin B <sub>2</sub>	(d)	Unhealthy skin
(e)	(f)	Night blindness
Vitamin C	(g)	(h)
(i)	Phylloquinone	Blood taking longer to clot
Vitamin D	Cholecalciferol	(j)

b) Give **five** factors to consider when choosing clothes.

(5mks)

c) Give **five** qualities to look for in a pair of cutting out shears.

(5mks)

18. a) Explain why food labels are important to a consumer.

(10mks)

b) Discuss the importance of consumer education.

(10mks)



# **CROSS COUNTRY EXAMS**

**441/ 2  
HOME SCIENCE  
PAPER 2  
CLOTHING AND TEXTILES  
(PRACTICAL)**

A pattern of a child's skirt is provided. You are advised to study the sketches, the questions and the layout before you begin the test.

## **MATERIALS PROVIDED**

1. A – FRONT YOKE  
B – SKIRT FRONT  
C – SKIRT BACK  
D – POCKET  
E – WAIST BAND
2. Plain light weight cotton fabric 50cm long by 91cm wide
3. Serving thread to match the fabric

## **THE TEST**

Using the materials provided, cut out and make the right half of the skirt to show the following

- a) Working of the dart at the back skirt
- b) Preparation and attachment of the patch pocket
- c) Joining the front yoke with the skirt front using an overlaid seam (do not neaten)
- d) Joining the side seam using a neatened open seam
- e) Preparation of the waist band
- f) Attaching the waist band
- g) Neatening the hem by edge stitching

SKIRT VIEW

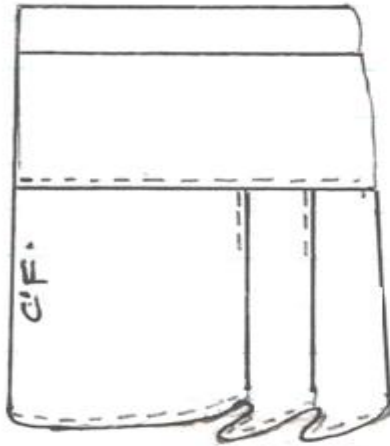

**FRONT VIEW**

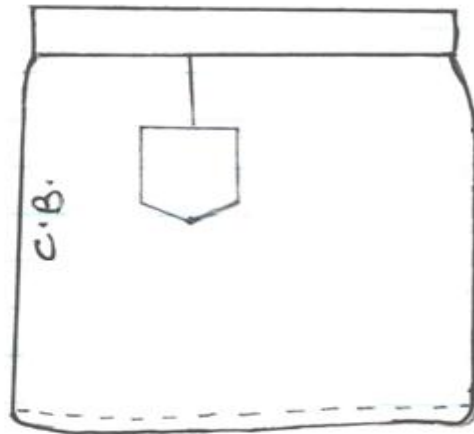

**BACK VIEW**

**LAYOUT (NOT DRAWN TO SCALE)**

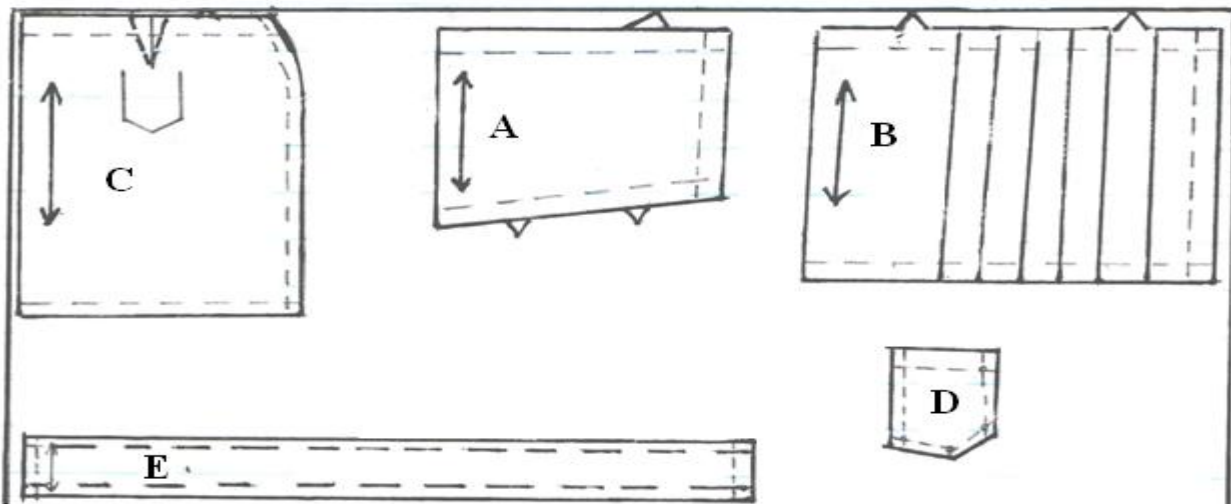

NB: At the end of the examination, firmly sew to your work, on a single fabric a label bearing your name

Remove unwanted threads and pins on your work

Any pattern piece that has not been stitched should be attached to your work before handling it for marking

# **CROSS COUNTRY EXAMS**

102/1

**KISWAHILI**

**KARATASI YA 1**

**(INSHA)**

**1. SWALI LA LAZIMA.**

Visa vya dhuluma dhidi ya mtoto wa kike vimeongezeka sana nchini. Andika taarifa ya hali hii nchini.

2. Uhifadhi wa mazingira una manufaa mengi kwa binadamu .Thibitisha.

3. Kutangulia si kufika.

4. Malizia kwa.....tulifukumana huku nyuso zetu zikiwa na tabasamu la matumaini.

# **CROSS COUNTRY EXAMS**

---

102/2

**Kiswahili**

Karatasi 2

Lugha

1. **UFAHAMU**

**Soma kifungu kifuatacho ujibu maswali:**

Limeibuka swala kwamba polisi waliokuwa wakiongoza mashtaka mahakamani sasa watakuwa chini ya Mkuu wa sheria si kamishina wa polisi. Ni hatua iliyo na mashako katika utekelezaji na usimamizi wa sheria.

Hatua hiyo itasaidia kuhakikisha kwamba washtakiwa watapata haki kamili na kuzuia visa ambapo polisi wakati mwingine walikuwa wakiwasingizia washtakiwa madai ya kiongozi wa mashtaka.

Polisi hawapaswi kutekeleza majukumu Fulani katika maongozi ya sheria kwa kuruhusiwa kuwatia nguvuni washtakiwa, kuwatayarishia mashtakak na halafu kuwafikisha mahakamani.

Maafisa husika sharti wafunzwe upya kuongoza mshtaka kuambatana na sheria wala si kanunbi za polisi wanaoongoza mashtaka, wew mawakili waliosomea uanasheria ipasavyo sawa na mawakili hao wengine. Hali hii itazuia visa ambapo wakili huwa anafahamu sheria kuliko kiongozi wa mashtaka.

Mawakili zaidi umma wafaa kutengewa wasio na pesa za kuwalipa mawakili wa kibinafsi kuwatetea. Hatua hizo zinaharakisha kesi zirundikanazo mahakamani na kupunguza idadi ya washtakiwa wanaowekwqa rumande na hitilafu za kisheria.

***Maswali:***

(a) Yape makala haya anwan mwafaka. (ala

1)

.....  
.....

(b) Kwa mujibu wa makala fafaua utekelezaji wa sheria mahakamani umetiwa sura mpya.

(ala2)

.....  
.....  
.....  
.....

(c) Thibitisha kuwa washtakiwa nchini Kenya wamekuwa wakikosa haki.

(ala2)

.....  
.....

(d) Shughuli za mahakama na utekelezaji sheria kuboreshwa. Eleza.

(ala3)

.....  
.....  
.....

(e) (i) Orodhesha majukumu ambayo polisi hawafai kuyatekeleza kisheria.

(ala2)

.....  
.....

.....

(ii) Eleza kwa nini washtakiwa wengi huwekwa rumande.

(ala1)

.....  
.....

(iii) Eleza sababu muhimu inayowakataza polisi kutekeleza majukumu uliyaorodhesha katika sehemu ya

(e) (i)

(ala1)

.....  
.....

.....

(f) Eleza maana ya:

(ala3)

(i) Rumande

.....  
.....  
(ii) Himaya  
.....

.....  
(iii) Zirundikanazo  
.....  
.....

2

**MUHTASARI/UFUPISHO: (ALAMA 15)**

**Soma taarifa ifuatyo kasha ujibu maswali kulingana na maagizo:**

Imesemwa na kurudiwa tena na tena kwamba , iwapo tuna maono ya kujiondoa katika umaskini wa kupindukia , ni lazima tukipe kilimo umuhimu. Zaidi ya Wakenya milioni kumi wamo katika hatari ya kufa njaa katika maeneo mbali mbali kwa sasa kufuatia uhaba wa chakula nchini.

Kiini kikubwa cha njaa hiyo ni mapuuzo ya muda mrefu katika sekta ya kilimo. Imesahaulika kuwa karibu asilimia sabini na tano ya Wakenya wanategemea kilimo kwa chakula na mapato ya kifedha kila siku. Kilimo hutoa robo tatu kwa wananchi na pia kuletea serikali karibu robo ya mapato yake kutokana na mauzo ya mazao katika mataifa ya nje.

Wataalamu wa maswala ya zarra wanaeleza kuwa pato la nchi linalotokana na kilimo huangamiza njaa mara nne zaidi ya mapato yanayotokana na shughuli nyinginezo za kiuchumi. Hiyo ni kwa sababu shughuli za kilimo hulenga kuzalisha vyakula moja kwa moja. Imebainika kuwa, katika mataifa mengi yanayostawi, asilimia sabini na tano ya wananchi huishi katika maeneo ya mashambani na idadi hii hutegemea kilimo kujimudu kimaisha ilhali hapa Kenya ni asilimia nne peke ya bajeti inayowekezwa katika kilimo. Kwa wakati huu, ushuru unaotowza bidhaa za kilimo katika maeneo haya umebainika kuwa mkubwa. Hii imepelekwa wekezaji katika kilimo kupungua na hivyo kuchangia kukithiri kwa baa la njaa.

Wakati umewadia kwa serikali za Afrika na wapangaji wa masuala ya uchumi kuweka juhudi maradufu katika kushabiki kilimo ili kumaliza njaa na umaskini. Kuna haja ya kuwajulisha,kuwahimiza na kuwaelimisha wakulima wa mashamba madogo madogo kuhusu mihimili ya zaraa kama vile uzalishaji wa matunda na mboga, ufugaji wa ndege, samaki na ng'ombe mbali na kuweka mikakati ya kuanzisha nafasi za kazi katika sekta ya kilimo.

Serikali itafikia lengo hili iwapo itaanza kilimo, kupunguza gharama za pembejeo za kilimo, kuweka sera zinazodhibiti uuzaji na ununuzi wa vyakula hasa baina ya mataifa na kuongeza sehemu ya bajeti inayotengewa kilimo. Bila hilo hautakuwa na linguine bali kukimbilia mataifa yaliyostawi kuomba misaada ili kuwanusuru raia wetu kutokana na gharama ya njaa.

**Maswali:**

- (a) Fupisha aya mbili za mwanzo.(Maneno 50-55)  
(ala6)

**Matayarisho**

.....  
.....  
.....  
.....  
.....  
.....  
.....  
.....  
.....  
.....  
.....  
.....  
.....  
.....  
.....  
.....  
.....  
.....  
.....  
.....  
.....  
.....

**Jibu**

.....  
.....  
.....  
.....  
.....  
.....  
.....  
.....  
.....  
.....  
.....  
.....  
.....  
.....  
.....  
.....  
.....  
.....  
.....  
.....  
.....  
.....

**3. MATUMIZI YA LUGHA –ALAMA 40**

- (a) Bainisha sauti mbili aina ya likwidi.  
(ala2)

.....  
.....  
.....  
.....  
.....  
(b) Andika upya sentensi ifuatayo ukitujmia -0- rejeshi tamati.

(ala1)

Debe ambalo humwaga maji lina tundu.  
.....  
.....  
.....

(c) Unda nomino mbili kutokana na kitenzi 'dhalimu'

(ala2)  
.....  
.....  
.....

(d) Neno 'kiongozi' ni mofimu aina gani?

(ala1)  
.....  
.....  
.....

(e) Ainisha yambwa katika sentensi :

(ala2)

Shivambo alimnunulia babake simu.  
.....  
.....  
.....

(f) Huku ukitoa mfano, eleza maana ya sentEnsi tatanishi.

(ala2)  
.....  
.....



.....  
.....  
(g) Iweke nomino ‘pua’ katika ngeli yake.  
(ala1)

.....  
.....  
(h) Eleza matumizi ya ‘li’ kama ilivyotumika katika sentansi ifuatayo:  
(ala1)  
Tunda li mezani

.....  
.....  
(i) Tunga sentensi ukitumia kiwakilishi cha jumla katika ngeli ya KI-VI.  
(ala2)

.....  
.....  
(j) Changanua sentensi ifuatayo ukitumia matawi.  
(ala4)  
Amina hakwenda shuleni wala kuhudhuria ibada.

.....  
.....  
(k) Tumia kwa kutunga sentensi kuonyesha:  
(ala2)

(i) Kitumizi

.....  
.....  
.....

(ii) Umilikaji

.....  
.....  
.....

(l) Ainisha virai katika sentensi ifuatayo.  
(ala2)

Amefundishwa kupika vizuri na mamake.

.....  
.....  
.....

m) Eleza tofauti kati ya sentensi hizi.  
(ala2)

Angeimba vizuri angetuzwa

Angeliimba vizuri angelituzwa

.....  
.....  
.....

.....

.....  
.....  
(n) Tumga sentensi kuonyesha tofauti kati ya.

Landa na Randa

.....  
.....  
(o) Kitenzi kwama kiko kauli (hali )ya

.....  
.....  
(p) (i) Nini maana ya nomino dhahania.  
(ala1)

.....  
.....  
(ii) Toa mfano mmoja wa nomino dhahania.  
(ala1)

.....  
.....  
(q) Ukitoa mifano mwafaka, onyesha matumizi mawili ya koloni(☺ katika sarufi ya Kiswahili.

(r) Andika sentensi ifuatayo katika usemi wa taarifa.

“Mzee, gari la moshi huondoka hapa saa ngapi?” Mgeni aliuliza.

.....  
.....  
.....

(s) Andika kinyume cha sentensi hii.

(ala2)

Kijakazi alihuzunika mtoto alipopotea.

.....  
.....  
.....

(t) Taja na ueleze aina ya kielezi kilichotumika katika sentensi.

(ala2)

Wanafunzi waadilifu washauriwa watembe makundimakundi

.....  
.....  
.....

4. ISIMU JAMII –ALAMA 10

(a) Toa ushahidi kuwa Kiswahili ni lahaja ya Kibantu.

# **CROSS COUNTRY EXAMS**

---

KISWAHILI

Karatasi ya 3

**(FASIHI)**

**1. SEHEMU A: USHAIRI (LAZIMA)**

Eti

Mimi niondoke hapa  
Niondoke hapa kwangu  
Nimesaki, licha ya risasi  
Vitisho na mauaji, siondoki

Mimi

Siondoki  
Siondoki siondoki  
Niondoke hapa kwangu!  
Kwa mateke hata na mikuki  
Marungu na bunduki, siondoki

Hapa

Siondoki  
Mimi ni Pahame!  
Niondoke hapa kwangu!  
Fujo na ghasia zikizuka  
Na kani ya waporaji, siondoki

Haki

Siondoki  
Kwangu siondoki  
Niondoke hapa kwangu!  
Nawaje; waje wanaokuja  
Mabepari wadhalimu, siondoki

Kamwe

Siondoki  
Ng'oo hapa kwangu!  
Katizame chini mti ule!  
Walizikwa babu zangu, siondoki

Sendi

Nende wapi?  
Si hapa kitovu changu  
Niondoke hapa kwangu  
Wangawa na vijikaratasi  
Si kwamba hapa si kwangu, siondoki

Katu  
Siondoki  
Sihitaji karatasi  
Niondoke hapa kwangu  
Yangu mimi ni ardhi hii  
Wala si makaratasi, siondoki

### Maswali

- a) Shairi hili ni la aina gani? Kwa nini (alama 2)
- b) Taja masaibu anayopitia mzungumzaji (alama 4)
- c) Eleza toni ya shairi hili (alama 2)
- d) Eleza muundo wa shairi hili (alama 3)
- e) Tambua matumizi ya mbinu ya usambamba (alama 2)
- f) Andika ubeti wa tano kwa lugha nathari (alama 4)
- g) Tambua idhini moja ya mtunzi (alama 1)
- h) Eleza maana ya maneno yafuatayo kama yalivyotumika katika shairi (alama 3)
- (i) Karatasi
- (ii) Nimesaki
- (iii) kitovu

### 2SEHEMU B TAMTHILIA YA KIGOGO

2. Uliona nini kwa huyo zebe wako ? Eti mapenzi!

- f. Eleza muktadha wa dondoo. (al. 4)
- g. Andika mbinu za lugha zinazojitokeza kwenye dondoo hili (al. 4)
- h. Taja hulka za mnenaji unajitokeza katika dondoo. (al. 2)
- i. Mwanamke ni kiumbe wa kukandamizwa. Thibitisha kauli hii ukirekjelea tamthilia. (al. 10)

3. wa kurejelea tamthilia ya 'Kigogo ya Pauline Kea, onyesha jinsi ambavyo viongozi wengi katika nchi za kiafrika wamejawa na tamaa. (alama 20)

### **SEHEMUC. RIWAYA YA CHOZI LA HERI (ASSUMPTA MATEI)**

4. "Kwa kweli ni hali ngumu hii"

Weka dondoo katika muktadha wake.

(alama 4)

Ni hali gani yamsemewa inayorejelewa kwenye dondoo.

(alama 16)

5) Ukabila ni tatizo sugu katika nchi nyingi za Kiafrika. Tetea kauli hii ukilejelea Chozi la Heri

(al.

20)

**Alifa Chokocho na Dumu Kayanda: Tumbo Lisiloshiha na Hadithi nyingine**

**jibu swali la 6 au la 7**

6. Ukirejelea hadithi zifuatazo, eleza jinsi maudhui ya mapenzi na asasi ya ndoa yanavyojitokeza.

(alama 20)

- a) Mapenzi ya kifaurongo
- b) Masharti ya kisasa
- c) Ndoto ya Mashaka
- d) Mtihani wa maisha

Au

**Shibe inatumaliza : Salma Omar Hamad**

7. "Hiyo ni dharau ndugu yangu. Kwa nini kila siku tunakula sisi kwa niaba ya wengine?"

- a) Eleza muktadha wa dondoo hili. (alama 4)
- b) Eleza sifa za msemaji. (alama 6)
- c) Eleza jinsi viongozi wanavyokuwa wabadhirifu. (alama 10)

**SEHEMU YA E: FASIHI SIMULIZI**

8a) Fafanua mchakato/fomula ya uwasilishaji wa vitendawili.

(alama 4)

b) Linganisha naulinganue vitendawili na methali.

(alama 10)

c) Toa sababu sita za kudidimia kwa fasihi simulizi.

(alama 6)

# CROSS COUNTRY EXAMS

## Physics

### Paper 1

1. 50 drops of a liquid were released from a burette which was originally reading  $22\text{cm}^3$  to give new reading of  $56\text{cm}^3$ . Calculate the volume of each drop.  
(2mrks)
  
2. A uniform plank of wood weighing  $50\text{N}$  and of length  $5\text{m}$  is suspended by two ropes **A** and **B**  $1.5\text{m}$  apart. **A** is  $2\text{m}$  from end and **B** is  $1.5\text{m}$  from the other end as shown in fig 1 below. A block of weight  $100\text{N}$  is suspended from the centre of the plank.

Calculate the tension  $T_A$  on the string **A**.  
(3mrks)

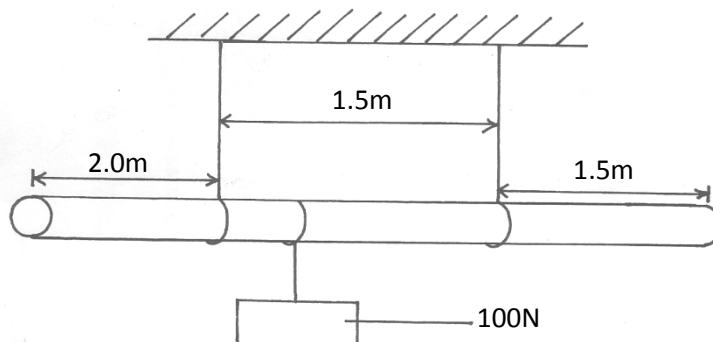



3. The fig below shows a horizontal tube with two vertical pipes **X** and **Y** dipped in water. Air flows through the tube from right to Left. The water level in **X** is low lower than in **Y**.

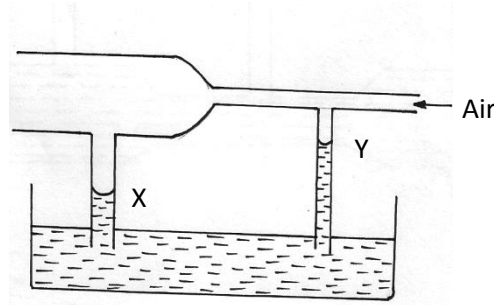

Explain this observation  
(2mrks)

.....  
.....

4. Some water is heated in a beaker from  $0^{\circ}\text{C}$  sketch the graph of mass **y** axis verses temperature for the water.

(1mrk)

5. Two aluminum rods **A** and **B** of the same length are held over a burner flame. Equal pleads of wax are attached to the ends as shown below.

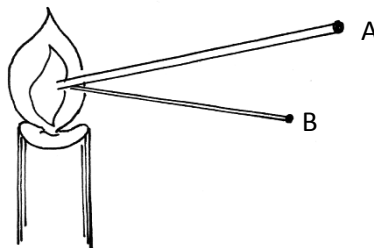

It is observed that the wax on **A** melts faster. Explain  
(2mrks)

.....  
.....

6. A steel sphere **A** is released in a tall transparent water jar containing water. At the same time and height another similar steel sphere **B** is released in air sketch on the axes below the velocity time graphs for sphere **A** and **B**.

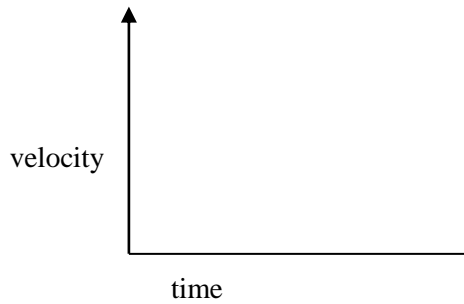

Sphere **A**  
(2mrks)

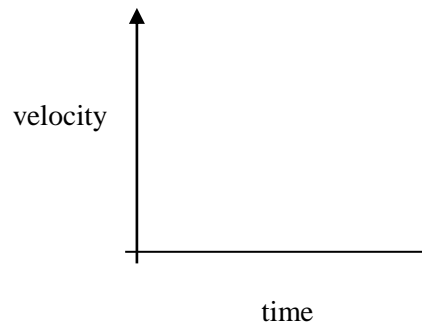

Sphere **B**

7. Water is not a suitable barometric liquid. Explain

(1mrk)

.....  
.....

8. A pipe of diameter 6cm is connected to another of diameter 30mm. If water flows in the wider pipe at a speed of  $4\text{ms}^{-1}$ . Determine the speed of the water in the narrow pipe.  
(3mrks)

9. A body is projected vertically upwards from the top of a building. Assuming that it lands at the base of the building. Sketch the velocity time graph for this motion.  
(2mrks)

10. A student heated equal amount of water in two aluminium containers **A** and **B** by a flame of equal hotness. If **A** was bigger than **B**, in which container will it take longer time to boil the water and why?  
(2mrks)

.....  
..  
.....  
.  
.....

11. 0.2 kg of copper at  $80^{\circ}\text{C}$  is put in a well lagged brass calorimeter of mass 0.1kg containing 0.16kg of sea water at  $20^{\circ}\text{C}$ . Calculate the final steady temperature of the mixture.

Take specific heat capacity of Copper =  $400 \text{ J kg}^{-1}\text{K}^{-1}$

Brass =  $380 \text{ J kg}^{-1}\text{K}^{-1}$

Sea water =  $3900 \text{ J kg}^{-1}\text{K}^{-1}$

(3mrks)

12. State **two** features that make the clinical thermometer more sensitive.

(2mrks)

.....  
.....  
..

**SECTION B (55MARKS)**

13. (a) The figure below represents a tube through which a liquid is flowing as shown by the arrow

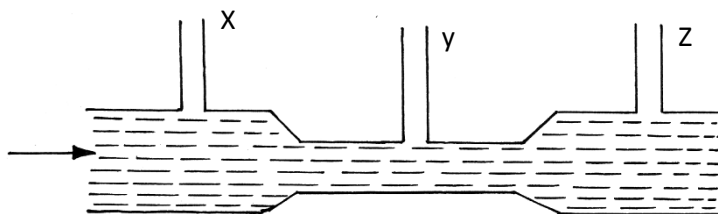

On the diagram show the relative positions of the level of the liquid in sections marked **X**, **Y** and **Z**.

(1mrk)

(b) A lawn sprinkler has 20 holes each of cross-sectional area  $2 \times 10^{-2} \text{cm}^2$  is connected to a hose pipe of cross-sectional area  $2.4 \text{cm}^2$ . If the speed of water in the hose pipe is  $1.5 \text{m/s}$ .

(3marks)

(i) Calculate the flow rate in the hose pipe.

(3marks)

(ii) The speed of water as it emerges from the hose pipe

(3marks)

14. The figure below shows a ball of mass  $50 \text{kg}$  being thrown from the top of a wall  $20 \text{m}$  high with a horizontal velocity of  $20 \text{m/s}$ . It struck the piston **A** of hydraulic lift and no water splashed out. The other piston **B** had a weight of  $25200 \text{N}$  placed on it. Assuming the top was opened at the time the ball struck the piston **A**.

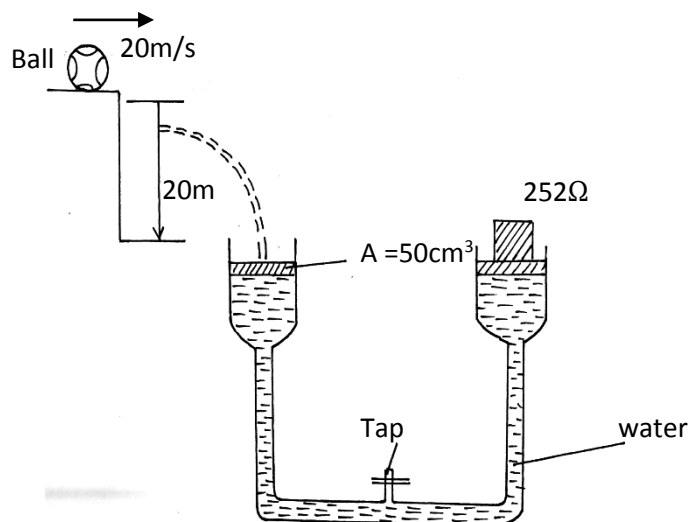



15. (a) State the principal of transmission of pressure.  
(1mrk)

.....

- (b) The figure below shows the principle of a hydraulic force.

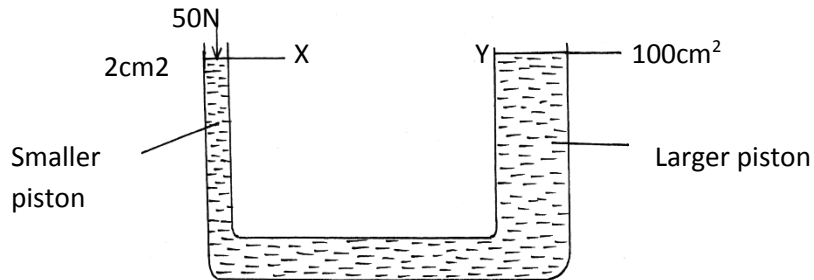

16. (a) State the pressure law for ideal gas.  
(1mrk)

.....

- (b) At  $20^\circ\text{C}$  the pressure of a gas is  $50\text{cm}$  of mercury . At what temperature would the pressure of the gas fall by  $30\text{cm}$  of mercury. Give the temperature in degree celsius.  
(3mrks)

- (c) Define the absolute zero of the Kelvin temperature scale.  
(1mrk)

.....

- (d) A hole of area  $2.0\text{cm}^2$  at the bottom of a tank  $2\text{m}$  deep is closed with a cork. Determine the force on the cork when the tank is filled with water. Take density of water  $= 1000\text{kg/m}^3$  and  $g = 10\text{m/s}^2$

(4mrks)

17. (a) Define specific heat capacity.  
(1mrk)

.....

- (b) In an experiment to determine the latent heat of water, steam at 100°C was passed into water contained in a well lagged copper calorimeter.

- Mass of calorimeter = 60g
- Initial mass of water = 80g
- Initial room temperature of water = 15°C
- Final temperature of mixture = 45°C
- Final mass of water + calorimeter + condensed steam = 160g

Specific heat capacity of water =  $4200 \text{ J kg}^{-1} \text{ } ^\circ\text{C}^{-1}$  and specific heat capacity of copper =  $390 \text{ J kg}^{-1} \text{ } ^\circ\text{C}^{-1}$

Calculate :

- (i) Mass of condensed steam  
(1mrk)

- (ii) Given that  $L_v$  is the specific latent heat of the vaporization of steam,

- (a) Write an expression for the latent heat of vaporization of steam  
(2mrks)

- (b) Determine the value of  $L_v$   
(2mrks)

18. (a) State Hooke's law  
(1mrk)

.....

- (b) The graph shows the variation of extension of a helical spring with the load hanging on it.

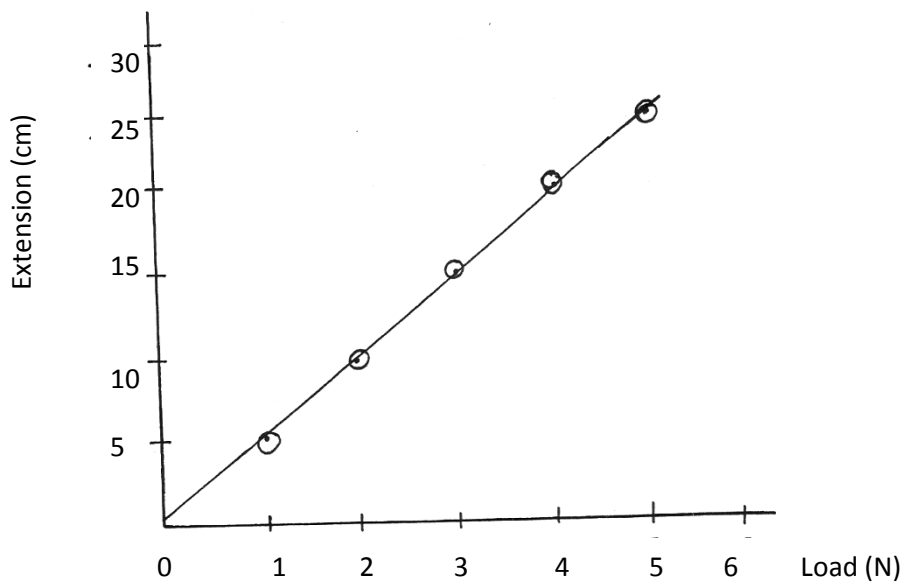

Determine from the graph the proportionality constant of the spring.  
(3mrks)

- (c) State **two** factors that affect the proportionality constant of a vertical string.  
(2mrks)

.....  
.....

(ii) \_\_\_\_\_  
specific latent heat of vaporization of steam

Given that the  $L_v$  is the

- (a) Write an expression for the latent heat of vaporization of steam.  
(2mrks)

- (c) Determine the value of the  $L_v$ .  
(2mrks)



# CROSS COUNTRY EXAMS

## PAPER 2

### SECTION A (25 MARKS)

1. A ray is incident on two mirrors inclined at  $60^\circ$  as shown in the diagram below. (2mks)

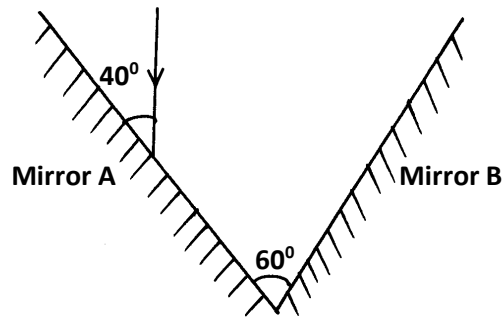

Determine the angle of reflection on mirror **B**, hence trace the path of the ray as it leaves mirror **B**.

2. State and explain the observation made when an acetate rod rubbed with fur is brought close to the cap of a negatively charged electroscope.

(2mks)

.....  
.....

3. State how polarization is reduced in a dry cell. (1mk)

.....  
.....

4. Distinguish between a P-type and a N-type extrinsic semiconductors. (2mks)

.....  
.....

.....  
.....

5. State one similarity and one difference between the gamma rays and x-rays based on the mode of generation of the radiations.

i) Similarity

(1mk) .....

ii) Difference

(1mk) .....

6. X-rays are produced by a tube operating at  $10^4$  Volts. Calculate the wavelength of the radiation.

(Take  $h=6.63 \times 10^{-34}$ Js,  $e=1.6 \times 10^{-19}$ C,  $c = 3 \times 10^8$ m/s)

(3mks)

7. State how a vertical trace can be obtained on the screen of a cathode ray oscilloscope. (1mk)

.....  
.....

8. A boat sends a sound signal in the middle of Lake Victoria and an echo is heard after 6 seconds. Determine;

i) The depth of the lake.

(2mks)

ii) The frequency of the signal stated in (i) above.

(1mk)

(Take speed of sound in water =  $1440\text{ms}^{-1}$ , wavelength =  $0.4\text{m}$ )

9. A concave mirror produces an erect image of magnification **2**. If the focal length of the concave mirror is  $30\text{cm}$ , find the distance of the object from the mirror. (3mks)

**(Hint: the image is virtual)**

10. State Lenz's law of electromagnetic induction. (1mk)

.....  
.....

11. The coils **P** and **S** are connected as shown below. **P** is connected to a battery, rheostat and a switch **K**. **S** is connected to a galvanometer **G**.

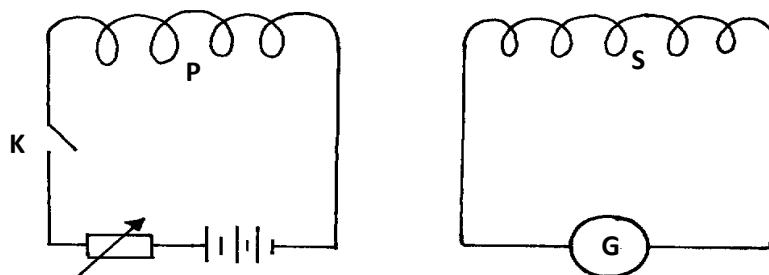

State the behaviour of the pointer on **G** in the following cases;

- i) When **K** is switched on (closed) (1mk)

.....  
.....

- ii) When **K** is opened.

(1mk)

.....  
.....

12. A current of **5mA** passes through a wire of length 1.0m, radius  $1.0 \times 10^{-4}$ mm and resistivity  $1.1 \times 10^{-6} \Omega \text{m}$ . Calculate the rate at which heat is given off by the wire. (Assume temperature is constant.)

(3mks)

**SECTION B (55 MARKS)**

13. a) Define the term photoelectric effect. (1mk)

.....  
.....

- b) The diagram below shows a circuit to investigate the photoelectric effect using a photocell.

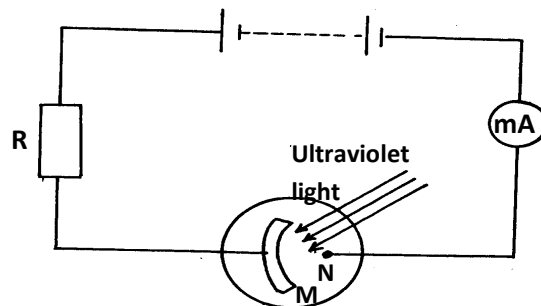

i) Explain why the milliammeter shows a reading when ultraviolet light is shone as in the diagram.

(3mks)

.....  
.....  
.....

ii) State with a reason how the milliammeter reading is affected when the intensity of light is increased.

(2mks)

.....  
.....

iii) State one practical application of a photocell.

(1mk)

.....  
.....

c) A laser beam of intensity  $2 \times 10^{-1} \text{Nm}^{-2}$  and wavelength  $\lambda = 5 \times 10^{-7} \text{m}$  hits a wall 5m away. How many photons per second are emitted?

(3mks)

(Take  $h = 6.6 \times 10^{-34} \text{Js}$ ,  $c = 3 \times 10^8 \text{ms}^{-1}$ )

14. a) Differentiate between a nuclear fussion and nuclear fission.

(2mks)

.....  
.....

b) The equation below represents a nuclear reaction.

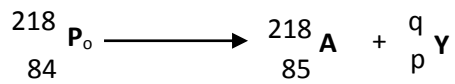

i) Determine the values of **p** and **q**.

(1mk)

**p**.....

**q**.....

ii) Identify **Y**..... (1mk)

c) The figure below represents deflection of various radiations from a radioactive source **S** placed in electric field between two plates **X** and **Y**.

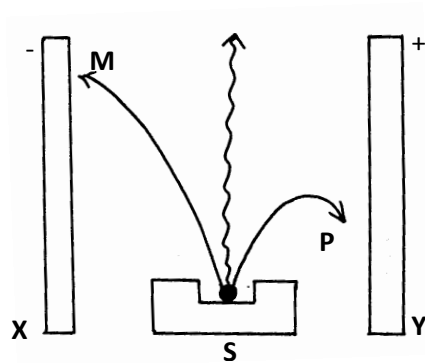

Identify the radiations marked with letters **M** and **P**.

(1mk) **M**.....

**P**.....

d) What do you understand by the term 'Random decay'

(1mk)

.....  
.....

e) A sample of radioactive substance initially has  $8 \times 10^{25}$  particles. The half life of the sample is 98 seconds. Determine the number of particles that will have decayed after 294 seconds. (3mks)

15. a) State Snell's law.  
(1mk)

.....  
.....

b) Find the angle of incidence of a ray of light on one phase of a  $60^\circ$  prism if the ray is just totally internally reflected on meeting the next face. (3mks)

**(Take refractive index of glass = 1.5)**

c) Explain why glass prisms are preferred for use in periscopes to plane mirrors. (1mk)

.....  
.....

d) i) State **two** ways in which a photographic camera is different from the human eye. (2mks)

.....  
.....

- ii) Determine graphically in the space below the position, size and nature of the image of an object 2cm high placed 30cm away from a diverging lens of focal length 20cm. (5mks)

(Use the scales vertically: 1cm rep 1cm, horizontally: 1cm rep 10cm)

16. a) Differentiate between a transverse wave and a longitudinal wave. (2mks)

.....  
.....

b) Water ripples are caused to travel across the surface of a shallow tank by means of a suitable straight vibrator.

The distance between successive crests is 3.0cm and the waves travel 25.2cm in 1.2s.

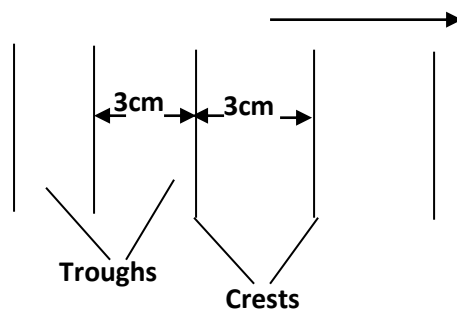

Calculate:

- i) The velocity of the waves.

(2mks)



ii) The frequency of the vibrator.

(3mks)

17. a) State any two disadvantages of direct transmission of electricity from power generating stations at a large current through the transmission cables.

(2mks)

.....  
 .....

b) The diagram below represents part of a domestic wiring system.

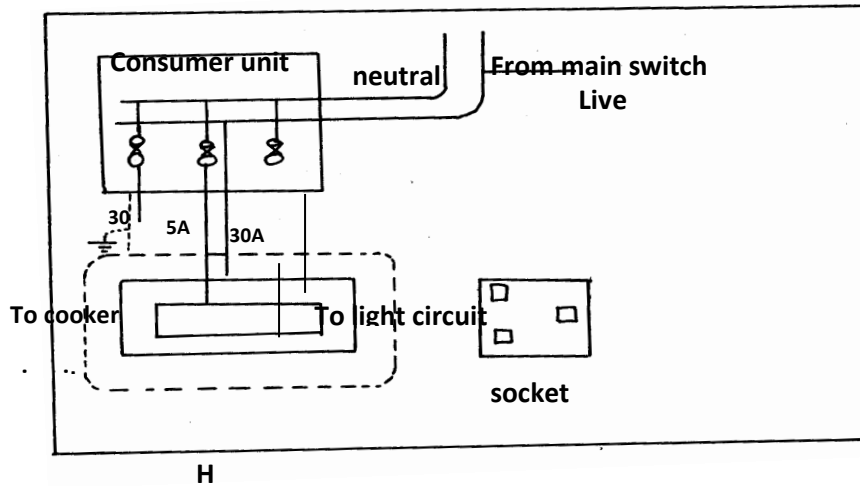

i) Identify any two mistakes in the wiring above and explain how they should be corrected. (4mks)

.....  
 .....

.....  
.....

ii) Identify the circuit **H** represented above.

(1mk)

.....  
.....

c) Complete the wiring to the socket in the wiring system **H** above.

(1mk)

18. a) The figure below represents a circuit diagram of three resistors connected to a 12V battery.

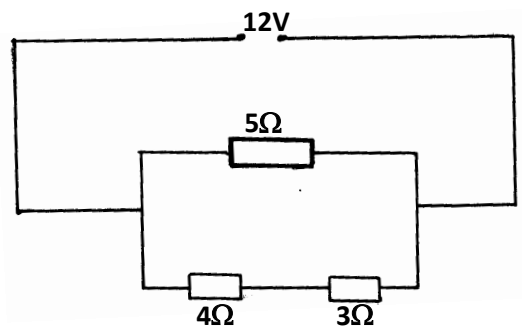

Determine;

i) The effective resistance for the arrangement above.

(2mks)

ii) The potential difference across the 3Ω resistor.

(3mks)

b) The figure below shows part of the circuit containing two capacitors  $C_1$  and  $C_2$ .

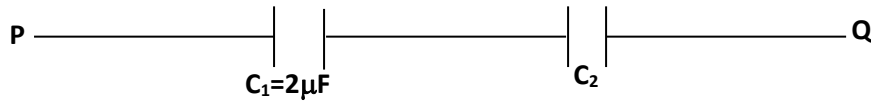

If  $C_1=2\mu\text{F}$  and the Pd across PQ is 150V while the total charge in the capacitors is  $1.8 \times 10^{-4}$  coulombs.

Determine the capacitance of  $C_2$ .

(4mks)

**FOR MARKING SCHEMES CALL 0705525657**