

# FORM 1 TERM 3 OPENER

## MATHEMATICS

NAME.....

ADM. NO.....CLASS.....

**MATHEMATICS**

**TIME: 2 HOURS**

### INSTRUCTIONS TO CANDIDATES

- Write your **Name** and **Adm. No** in the space provided.
- These papers consist of two sections; Section A and section B.
- Answer all questions in section A and Section B.
- Write all your working on the space provided.
- Marks are awarded for steps which are correctly worked.
- Calculators must not be used.

### **For Examiner's Use Only**

Question	1	2	3	4	5	6	7	8	9	10	11	12	13
Marks													

Question	14	15	16	17	18	19	20	21	22
Marks									

**TOTAL  
MARKS**

--

*This paper consists of 12 printed pages. Students should check the question paper to ensure that all the Pages are printed as indicated and no questions are missing.*



4. Evaluate  $\frac{1470^2}{\sqrt{7056}}$  using prime factors and leave your answer in prime factors form. (4mks).

5. Evaluate 
$$\frac{\frac{1}{2} \text{ of } 3\frac{1}{2} + 1\frac{1}{2}(2\frac{1}{2} - \frac{2}{3})}{\frac{3}{4} \text{ of } 2\frac{1}{2} \div \frac{1}{2}}$$
 (4mks).

6. Use number line to solve  $6 - (-4)$  (2mks).

7. Given that  $X= 4$  and  $y = -6$ , evaluate the following. (3mks).

$$6x - 3xy$$

8. Simplify (3mks)

$$\frac{a + b}{2} - \frac{2a - b}{3}$$

9. The ratio of boys and girls in a mixed school is 2:3. If there are 160 boys, how many girls are there? (3mks).

10. Find the ratio  $a:c$ , given that;

$$a:b = 7: 1, b:d = 1: 2, d: c = 2: e \quad (4mks).$$

11. The perimeter of a semicircular protractor is 14.28cm. Find its radius. (3mks)

12. The area of the sector of a circle is  $38.5\text{cm}^2$ . Find the radius of the circle if the angle subtended at the centre is  $90^\circ$ . (Take  $\pi = \frac{22}{7}$ ). (3mks).

13. A cylindrical column of fat has diameter 17.5cm and height 10cm. Calculate the density in  $\text{g/cm}^3$  of fat if the column has a mass of 2kg. (3mks)

14. Express the following measurements in 3 s.f (3mks)

a) 36.7892

b) 0.09854

c) 345204

15. Find the square root of 0.001952 using mathematical table. (3mks)

16. Arrange the following numbers in an ascending order. (3mks)

$$2^{7/8}, 14/5, 3, 17/9$$

**SECTION B 50 MARKS**  
**ANSWER ALL QUESTIONS IN THIS SECTION**

17. A rectangle measures 18cm by 12cm.

(a) If each dimension is reduced by 2cm, by what percentage is:

i). The perimeter reduced.

(3mks)

ii). The area of the rectangle reduced.

(3mks)

(b) If each dimension is reduced by 2%, by what percentage is the area of the rectangle reduced.  
(4mks).

18. (a) Study the equations below and complete the tables.

$$7x + 2y = 16$$

$$2x - y = 3$$

x	0	1	2
y			

x	0	2	4
y			

(b) On the same axis, draw the graphs of  $y = 2x - 3$  and  $y = 8 - \frac{7}{2}x$  (4mks)

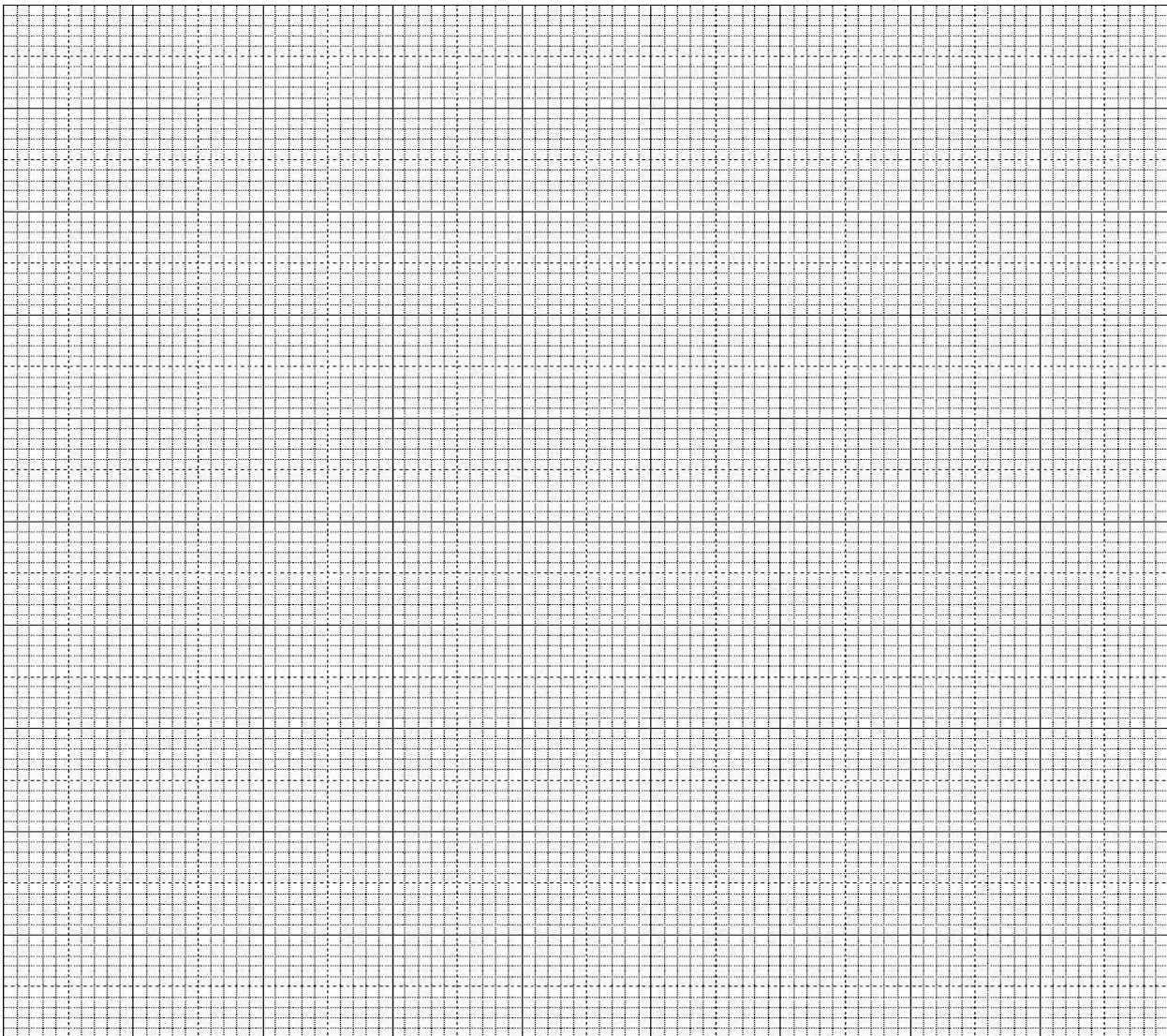



(c) Use the graph to solve the simultaneous equations; (2mks)

$$y = 2x - 3$$

$$y = 8 - \frac{7}{2}x$$

19. (a) Draw triangle ABC in which AB = 11cm, AC = 8cm and BC = 5.6cm. (2mks)

(b) Construct the bisectors of any two angles of the triangle and let the bisectors meet at R. (2mks)

(c) Draw the perpendicular from R to AB so that it cuts AB at M. (2mks)

(d) With centre R and the radius RM, Draw a circle. (2mks)

(e) Calculate the area of the circle. (2mks)

20. A carpenter constructed a closed wooden box with internal measurements 1.5m long by 0.8m wide and 0.4m high. The wood used in constructing the box was 1.0cm thick and had a density of 0.6 g/cm<sup>3</sup>.

a) Determine the:

i). Volume in cm<sup>3</sup> of the wood used in constructing the box. (3mks)

ii). Mass of the box in kg correct to 1dp. (2mks)

b) Identical cylindrical tins of diameter 10cm and height 20cm with a mass of 120g each were packed in the box. Calculate;

i). Maximum number of tins that were packed in the box. (3mks)

ii). Total mass of the box with the tins. (2mks)

21. Find the size of the angles marked with letters.

(a) (1mk)

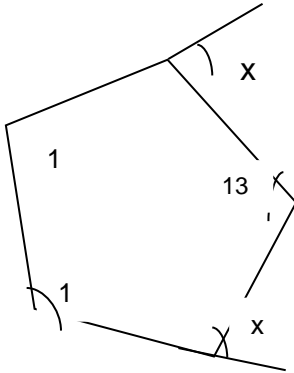

(b) (5mks)

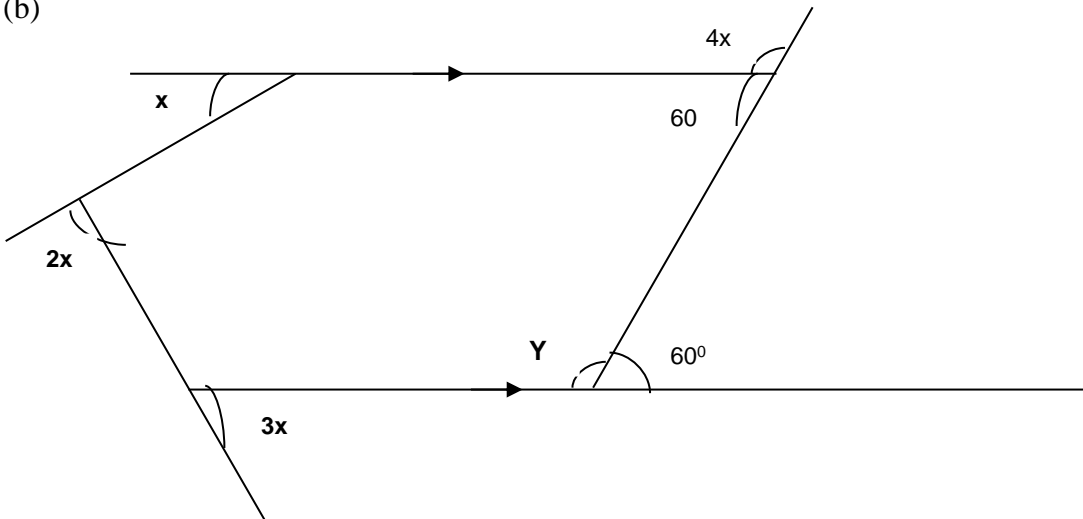

(c) (4mks)

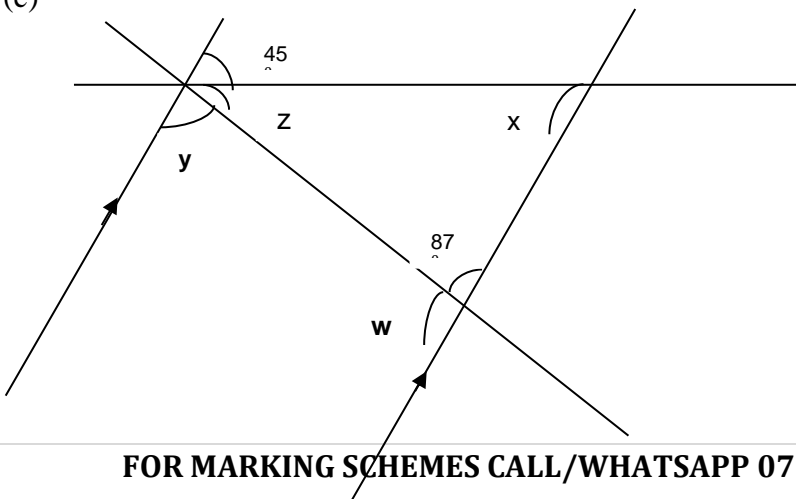

22. (a) The GCD of two numbers and their LCM is 360. If one of the numbers is 72, what is the other number? (3mks).

(b) When a number  $u$  is divided by 34 or 24 or 40, the remainder is always 5. Find the least value of  $u$ . (3mks)

(c) Three bells ring at intervals of 12minutes, 15minutes and 18minutes. If they sound together at 10:00 am;

i). After how long will they next sound together? (3mks).

ii). What time will this be?

(1mks)