A woman in a yellow tank top and dark shorts is captured mid-jump against a clear blue sky. She is wearing grey sneakers and has her arms and legs extended in a dynamic pose. The background shows a field of tall grass in the foreground and rolling hills in the distance.

TEST BANK

TENTH EDITION

**ESSENTIALS**  
OF **HUMAN** ANATOMY  
AND **PHYSIOLOGY**

ELAINE N. MARIEB

Exam

Name \_\_\_\_\_

**MULTIPLE CHOICE. Choose the one alternative that best completes the statement or answers the question.**

- 1) A section that divides the body on the longitudinal plane into equal right and left parts is called: 1) \_\_\_\_\_
  - A) median (midsagittal)
  - B) oblique
  - C) transverse
  - D) frontal
  - E) coronal
  
- 2) Which of the following is the correct sequence, going from simplest to most complex, in the levels of structural organization of the human body: 2) \_\_\_\_\_
  - A) chemical level, tissue level, cellular level, organ system level, organ level, organismal level
  - B) cellular level, chemical level, tissue level, organ system level, organismal level, organ level
  - C) chemical level, cellular level, tissue level, organ level, organ system level, organismal level
  - D) cellular level, chemical level, tissue level, organ level, organ system level, organismal level
  - E) cellular level, tissue level, chemical level, organ level, organ system level, organismal level
  
- 3) Which of these regions are associated with the parts of the arm: 3) \_\_\_\_\_
  - A) femoral, popliteal, patellar
  - B) brachial, antecubital, carpal
  - C) nasal, oral, occipital
  - D) pelvic, pubic, inguinal
  - E) acromial, sacral, gluteal
  
- 4) The muscular system consists of the: 4) \_\_\_\_\_
  - A) muscles in the walls of hollow organs
  - B) muscles of the heart and those in the walls of the hollow organs
  - C) skeletal muscles
  - D) skeletal muscles and the muscles of the heart
  - E) muscles of the heart
  
- 5) The lymphatic system: 5) \_\_\_\_\_
  - A) synthesizes vitamin D
  - B) responds to internal and external changes by activating appropriate muscles and glands
  - C) secretes hormones that regulate processes such as growth, reproduction, and nutrient use (metabolism) by body cells
  - D) picks up fluid leaked from blood vessels and returns it to the blood
  - E) produces heat
  
- 6) Which system covers the external surface of the body and manufactures vitamin D: 6) \_\_\_\_\_
  - A) endocrine system
  - B) skeletal system
  - C) nervous system
  - D) integumentary system
  - E) lymphatic system
  
- 7) Which of these regions are NOT associated with the ventral (anterior) portion of the head: 7) \_\_\_\_\_
  - A) oral
  - B) orbital
  - C) buccal
  - D) nasal
  - E) occipital
  
- 8) Which of the following systems is matched most accurately to the life function it provides: 8) \_\_\_\_\_

- A) respiratory system – digestion
- B) nervous system – excretion
- C) muscular system – maintaining boundaries
- D) integumentary system – movement
- E) nervous system – responsiveness

- 9) Which of the following elements of a control system detects a change: 9) \_\_\_\_\_
- A) receptor
  - B) control center
  - C) effector
  - D) stimulus
  - E) efferent pathway
- 10) Which of the following statements is correct regarding the location of the spleen and stomach: 10) \_\_\_\_\_
- A) both of these organs are located medially
  - B) both of these organs are located in the left upper quadrant
  - C) the spleen is located in the left upper quadrant and the stomach is located in the right upper quadrant
  - D) both of these organs are located in the right upper quadrant
  - E) the spleen is located in the right upper quadrant and the stomach is located in the left upper quadrant
- 11) Which of these is NOT a survival need: 11) \_\_\_\_\_
- A) oxygen
  - B) water
  - C) reproduction
  - D) body temperature
  - E) nutrients
- 12) Which of the following is the correct order of elements in a control system: 12) \_\_\_\_\_
- A) receptor, stimulus, afferent pathway, control center, efferent pathway, effector, response
  - B) stimulus, receptor, efferent pathway, control center, afferent pathway, effector, response
  - C) receptor, stimulus, efferent pathway, control center, afferent pathway, effector, response
  - D) stimulus, receptor, afferent pathway, control center, efferent pathway, effector, response
  - E) effector, stimulus, efferent pathway, control center, afferent pathway, receptor, response
- 13) Which of the following activities does not represent an anatomical study: 13) \_\_\_\_\_
- A) viewing muscle tissue through a microscope
  - B) studying how the nerves conduct electrical impulses
  - C) observing the parts of a reproducing cell
  - D) examining the surface of a bone
  - E) making a section through the heart to observe its interior
- 14) The dorsal body cavity houses the: 14) \_\_\_\_\_
- A) heart and lungs
  - B) spinal cord and brain
  - C) tongue
  - D) urinary and reproductive organs
  - E) digestive and reproductive organs
- 15) The stomach, liver, intestines, bladder, rectum, and reproductive organs are housed in the: 15) \_\_\_\_\_
- A) abdominopelvic cavity

- B) dorsal cavity
- C) spinal cavity
- D) cranial cavity
- E) thoracic cavity

- 16) Which of the following is NOT a necessary life *function*: 16) \_\_\_\_\_
- A) nutrients
  - B) maintaining boundaries
  - C) movement
  - D) responsiveness
  - E) metabolism
- 17) The study of the function of the body and body parts is called: 17) \_\_\_\_\_
- A) homeostasis
  - B) anatomy
  - C) physiology
  - D) irritability
  - E) negative feedback
- 18) Which of these regions in the abdominopelvic cavity are medial: 18) \_\_\_\_\_
- A) epigastric, umbilical, and hypogastric regions
  - B) umbilical, right lumbar, and left lumbar regions
  - C) epigastric, right, and left hypochondriac regions
  - D) iliac (inguinal), lumbar, and hypogastric regions
  - E) right and left iliac (inguinal), and hypogastric regions
- 19) The region that contains the navel is the: 19) \_\_\_\_\_
- A) umbilical region
  - B) orbital region
  - C) carpal region
  - D) anterior knee
  - E) inguinal region
- 20) The gluteal region is the: 20) \_\_\_\_\_
- A) posterior knee area
  - B) posterior surface of the head
  - C) shoulder blade region
  - D) buttock
  - E) curve of the shoulder
- 21) Which of the following orientation terms have opposite meanings (in humans): 21) \_\_\_\_\_
- A) medial and anterior
  - B) superficial and proximal
  - C) posterior and intermediate
  - D) distal and proximal
  - E) medial and distal
- 22) Your body thermostat is located in a part of the brain called the hypothalamus. Which of the following elements of a control system does this area in the brain represent: 22) \_\_\_\_\_
- A) stimulus
  - B) afferent pathway
  - C) efferent pathway

- D) effector
- E) control center

- 23) The ovary is part of which of the following two systems: 23) \_\_\_\_\_
- A) digestive and respiratory systems
  - B) reproductive and endocrine systems
  - C) digestive and endocrine systems
  - D) reproductive and respiratory systems
  - E) endocrine and respiratory systems
- 24) Elimination of metabolic wastes from the body is the function of the: 24) \_\_\_\_\_
- A) digestive and urinary systems
  - B) digestive system
  - C) urinary system
  - D) respiratory system
  - E) digestive and respiratory systems
- 25) Which ventral cavity subdivision has no bony protection: 25) \_\_\_\_\_
- A) spinal
  - B) pelvic
  - C) abdominal
  - D) cranial
  - E) thoracic
- 26) The system that controls and coordinates the body through hormones is the: 26) \_\_\_\_\_
- A) digestive system
  - B) nervous system
  - C) endocrine system
  - D) skeletal system
  - E) integumentary system
- 27) Which type of section could be used to separate the thoracic cavity from the abdominopelvic cavity: 27) \_\_\_\_\_
- A) dorsal                      B) transverse                      C) sagittal                      D) coronal                      E) ventral
- 28) Which of the following regional terms means the anterior surface of the elbow: 28) \_\_\_\_\_
- A) vertebral region
  - B) antecubital region
  - C) calcaneal region
  - D) scapular region
  - E) gluteal region
- 29) In describing the relationship of the thoracic and spinal cavities: 29) \_\_\_\_\_
- A) the thoracic cavity is superior to the spinal cavity
  - B) the thoracic cavity is medial to the spinal cavity
  - C) the thoracic cavity is proximal to the spinal cavity
  - D) the thoracic cavity is ventral to the spinal cavity
  - E) the thoracic cavity is inferior to the spinal cavity
- 30) Which of these structures is the most complex: 30) \_\_\_\_\_
- A) a tissue
  - B) a molecule

- C) a cell
- D) organ system
- E) an organ

31) Sarah fell while ice skating and broke a bone in her carpal region. Where is this region? 31) \_\_\_\_\_  
A) wrist                      B) shoulder                      C) lower leg                      D) hip                      E) knee

32) In anatomical position: 32) \_\_\_\_\_  
A) the body is erect with the feet parallel and the arms hanging at the sides with the palms facing forward  
B) the body is lying face up with the feet parallel and the arms at the sides with the palms facing forward  
C) the body is erect with the feet parallel and the arms hanging at the sides with the palms facing backward  
D) the body is lying face up with the feet parallel and the arms at the sides with the palms facing backward  
E) the body is lying face down with the feet parallel and the arms at the sides with the palms facing backward

33) The lungs and heart are in the \_\_\_\_\_ body cavity. 33) \_\_\_\_\_  
A) spinal  
B) thoracic  
C) abdominopelvic  
D) cranial  
E) dorsal

34) The ribs are located in the: 34) \_\_\_\_\_  
A) right and left iliac regions  
B) right and left hypochondriac regions  
C) right and left pubic regions  
D) right and left lumbar regions  
E) right and left inguinal regions

35) Positive feedback systems: 35) \_\_\_\_\_  
A) operate in such a way that the initial stimulus is enhanced and increases  
B) regulate heart and breathing rates, and operate in such a way that the initial stimulus is shut off or reduced  
C) regulate heart and breathing rates, and operate in such a way that the initial stimulus is enhanced and increases  
D) operate in such a way that the initial stimulus is shut off or reduced  
E) regulate heart and breathing rates

36) Which of the following orientation and directional terms have the same meaning (in humans): 36) \_\_\_\_\_  
A) superior and caudal  
B) inferior and cephalad  
C) anterior and dorsal  
D) inferior and cranial  
E) anterior and ventral

37) The system that takes in oxygen and releases carbon dioxide to the exterior is the: 37) \_\_\_\_\_  
A) muscular system  
B) respiratory system

- C) urinary system
- D) cardiovascular system
- E) reproductive system

38) In describing the relationship between the patellar and popliteal regions:

38) \_\_\_\_\_

- A) the patellar region is lateral to the popliteal region
- B) the patellar region is anterior to the popliteal region
- C) the patellar region is proximal to the popliteal region
- D) the patellar region is superior to the popliteal region
- E) the patellar region is distal to the popliteal region

**SHORT ANSWER. Write the word or phrase that best completes each statement or answers the question.**

*Fill in the blank or provide a short answer:*

39) A cut that is made along the midline is called a \_\_\_\_\_ section.

39) \_\_\_\_\_

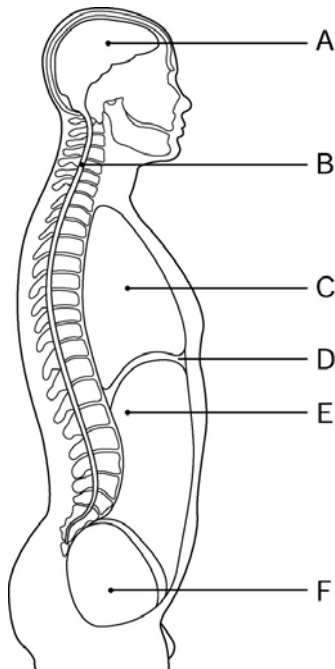

Figure 1.1

*Using Figure 1.1, identify the following:*

40) Label E points to the \_\_\_\_\_ cavity.

40) \_\_\_\_\_

*Fill in the blank or provide a short answer:*

41) A control mechanism that responds to a stimulus by decreasing its intensity is called a \_\_\_\_\_ mechanism.

41) \_\_\_\_\_

42) The larynx is an organ of the \_\_\_\_\_ system.

42) \_\_\_\_\_

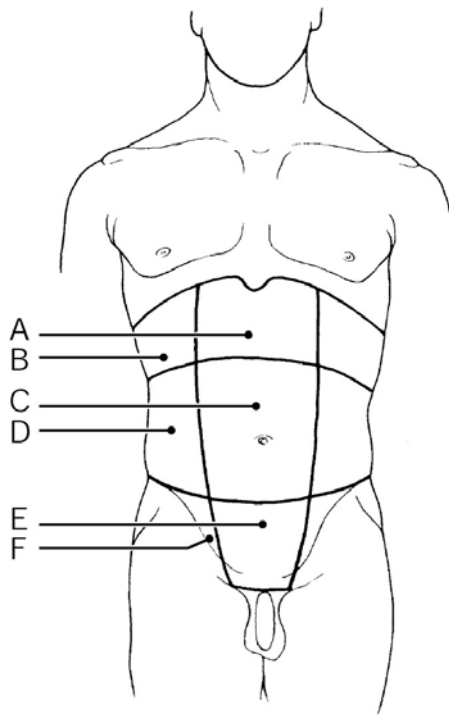

Figure 1.2

**Using Figure 1.2, identify the following:**

43) Label A points to the \_\_\_\_\_ region. 43) \_\_\_\_\_

*Fill in the blank or provide a short answer:*

44) The body's ability to maintain stable internal conditions is referred to as \_\_\_\_\_. 44) \_\_\_\_\_

45) The abdominal cavity has \_\_\_\_\_ quadrants and \_\_\_\_\_ regions. 45) \_\_\_\_\_

*Fill in the blank or provide a short answer:*

46) The navel is \_\_\_\_\_ to the spine. 46) \_\_\_\_\_

47) \_\_\_\_\_ is the process of breaking down ingested food in preparation for absorption. 47) \_\_\_\_\_



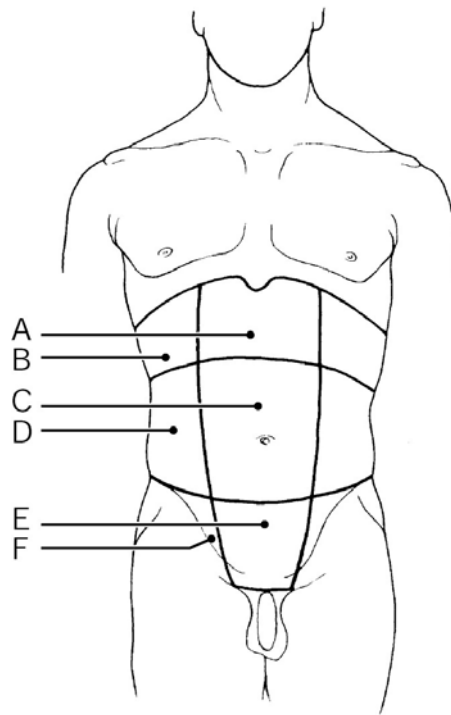

Figure 1.2

Using Figure 1.2, identify the following:

48) Label E points to the \_\_\_\_\_ region.

48) \_\_\_\_\_

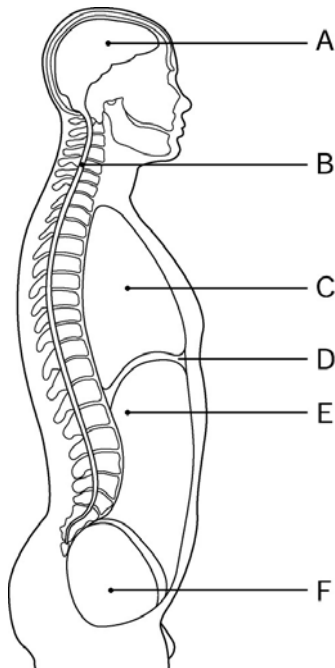

Figure 1.1

Using Figure 1.1, identify the following:

49) Label B points to the \_\_\_\_\_ cavity.

49) \_\_\_\_\_

50) Label F points to the \_\_\_\_\_ cavity.

50) \_\_\_\_\_

51) Ventral is a directional term synonymous with \_\_\_\_\_ in humans.

51) \_\_\_\_\_

*Fill in the blank or provide a short answer:*

52) Groups of cells that have a common function are termed \_\_\_\_\_.

52) \_\_\_\_\_

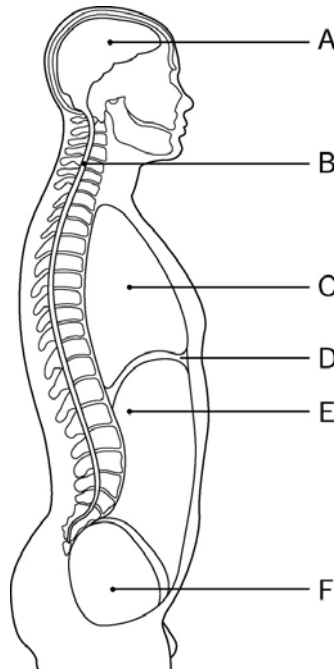

Figure 1.1

*Using Figure 1.1, identify the following:*

53) Label A points to the \_\_\_\_\_ cavity.

53) \_\_\_\_\_

*Fill in the blank or provide a short answer:*

54) The central region of the thoracic cavity containing the heart is called the \_\_\_\_\_.

54) \_\_\_\_\_

55) The system that functions in the storage of minerals, such as calcium, is called the \_\_\_\_\_ system.

55) \_\_\_\_\_

56) The component of a control system that provides the means for the control center's response (output) is called the \_\_\_\_\_.

56) \_\_\_\_\_

57) The thoracic cavity is \_\_\_\_\_ to the abdominopelvic cavity.

57) \_\_\_\_\_

58) The \_\_\_\_\_ system is composed of kidneys, bladder, ureters, and urethra.

58) \_\_\_\_\_

*Fill in the blank or provide a short answer:*

59) The ability to sense changes and react to them is termed \_\_\_\_\_ or \_\_\_\_\_.

59) \_\_\_\_\_

60) The armpit area is called the \_\_\_\_\_ region.

60) \_\_\_\_\_

61) The epigastric region is \_\_\_\_\_ to the right hypochondriac region of the abdominopelvic cavity.

61) \_\_\_\_\_

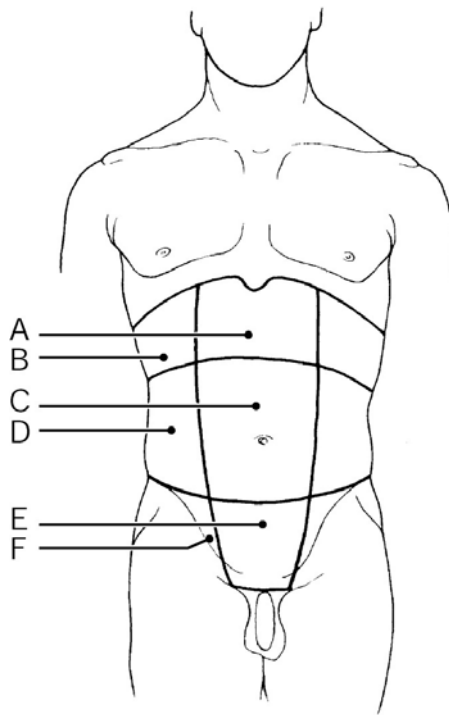

Figure 1.2

*Using Figure 1.2, identify the following:*

62) Label B points to the \_\_\_\_\_ region. 62) \_\_\_\_\_

63) Label C points to the \_\_\_\_\_ region. 63) \_\_\_\_\_

64) Blood is categorized as a \_\_\_\_\_ because it is composed of similar cells with a common function. 64) \_\_\_\_\_

65) The patellar region is \_\_\_\_\_ to the popliteal region. 65) \_\_\_\_\_

*Fill in the blank or provide a short answer:*

66) The cranial and spinal cavities are subdivisions of the \_\_\_\_\_ cavity. 66) \_\_\_\_\_

67) The function of the \_\_\_\_\_ system is to control body activities via hormones. 67) \_\_\_\_\_

*Fill in the blank or provide a short answer:*

68) \_\_\_\_\_ refers to all of the chemical reactions in the body. 68) \_\_\_\_\_

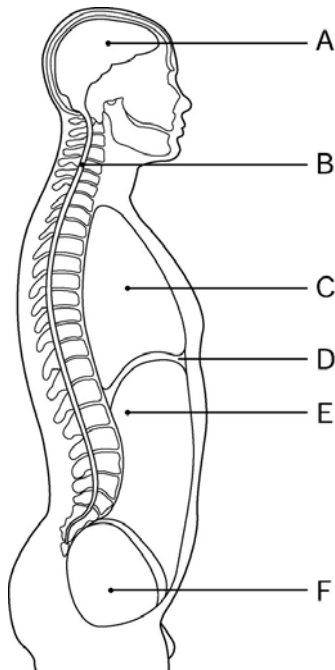

Figure 1.1

Using Figure 1.1, identify the following:

69) Label D points to the \_\_\_\_\_.

69) \_\_\_\_\_

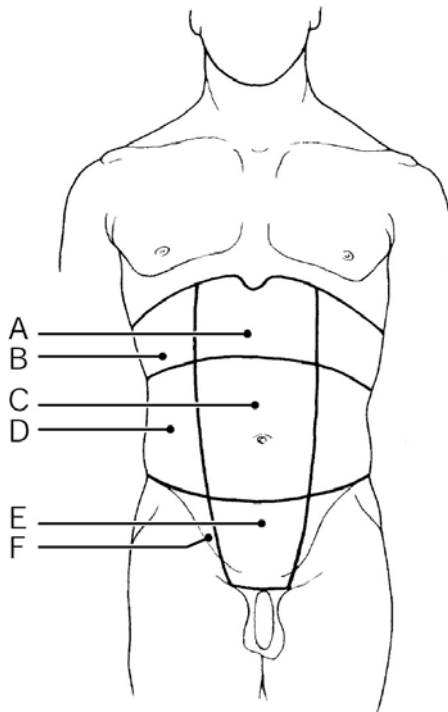

Figure 1.2

Using Figure 1.2, identify the following:

70) Label F points to the \_\_\_\_\_ region.

70) \_\_\_\_\_

Fill in the blank or provide a short answer:

71) The study of the body's small structures using a microscope is called \_\_\_\_\_.

71) \_\_\_\_\_

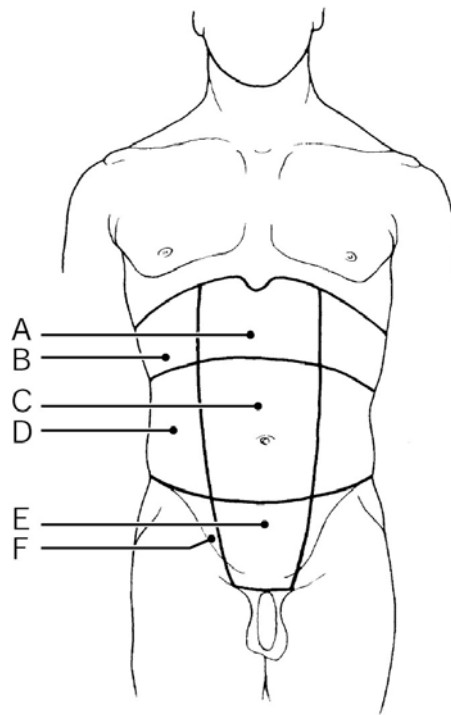

Figure 1.2

Using Figure 1.2, identify the following:

72) Label D points to the \_\_\_\_\_ region.

72) \_\_\_\_\_

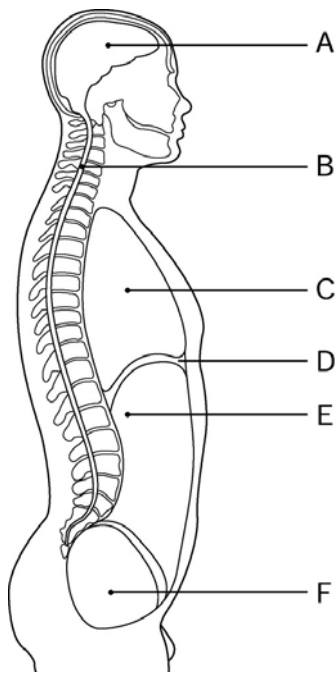

Figure 1.1

Using Figure 1.1, identify the following:

73) Label C points to the \_\_\_\_\_ cavity.

73) \_\_\_\_\_

Fill in the blank or provide a short answer:

- 74) The right and left iliac (inguinal) regions are lateral to the \_\_\_\_\_ region. 74) \_\_\_\_\_
- 75) The breakdown of ingested foods into simple molecules that can then be absorbed into the bloodstream is termed \_\_\_\_\_. 75) \_\_\_\_\_
- 76) The three medial regions of the abdominopelvic cavity are \_\_\_\_\_, \_\_\_\_\_, and \_\_\_\_\_. 76) \_\_\_\_\_
- 77) Blood clotting and the birth of a baby are examples of the \_\_\_\_\_ feedback mechanism. 77) \_\_\_\_\_

**TRUE/FALSE. Write 'T' if the statement is true and 'F' if the statement is false.**

- 78) The heel of the foot constitutes the plantar region. 78) \_\_\_\_\_
- 79) The lymphatic system collects fluids leaked by the cardiovascular system and returns them to the bloodstream. 79) \_\_\_\_\_
- 80) The spleen and the tonsils are part of the digestive system. 80) \_\_\_\_\_
- 81) The endocrine system is the fast-acting body control system. 81) \_\_\_\_\_
- 82) The thoracic cavity is separated from the abdominopelvic cavity by the diaphragm. 82) \_\_\_\_\_
- 83) The dorsal body cavity is subdivided into four quadrants and nine regions. 83) \_\_\_\_\_
- 84) As body temperature drops below normal, chemical reactions proceed too rapidly and body proteins begin to break down. 84) \_\_\_\_\_
- 85) The spinal cavity is part of the ventral body cavity. 85) \_\_\_\_\_
- 86) The hypogastric region is directly superior to the umbilical region. 86) \_\_\_\_\_
- 87) There is no physical structure that separates the abdominal cavity from the pelvic cavity. 87) \_\_\_\_\_
- 88) The highest level of structural organization in humans is the organ level. 88) \_\_\_\_\_
- 89) Most homeostatic control mechanisms are negative feedback reactions. 89) \_\_\_\_\_
- 90) *Proximal* means farther from the origin of a body part. 90) \_\_\_\_\_
- 91) The sacral region is on the ventral (anterior) body surface. 91) \_\_\_\_\_
- 92) Excretion is the process of removing wastes from the body. 92) \_\_\_\_\_

**MATCHING. Choose the item in column 2 that best matches each item in column 1.**

Match the following:

- |               |                                      |           |
|---------------|--------------------------------------|-----------|
| 93) Tarsal    | A) ankle                             | 93) _____ |
| 94) Inguinal  | B) area where thigh meets body trunk | 94) _____ |
| 95) Umbilical | C) navel                             | 95) _____ |

*Match the following:*

- |              |                    |           |
|--------------|--------------------|-----------|
| 96) Dorsal   | A) behind          | 96) _____ |
| 97) Ventral  | B) toward the side | 97) _____ |
| 98) Lateral  | C) in front of     | 98) _____ |
| 99) Superior | D) above           | 99) _____ |

*Match the following.*

- |   |                   |            |
|---|-------------------|------------|
| 100) Regulation of water and electrolytes | A) urinary system | 100) _____ |
|---|-------------------|------------|

*Match the following:*

- |                |                        |            |
|----------------|------------------------|------------|
| 101) Popliteal | A) posterior knee area | 101) _____ |
| 102) Oral      | B) mouth               | 102) _____ |

*Match the following.*

- |  |                    |            |
|--|--------------------|------------|
| 103) Heat production                             | A) nervous system  | 103) _____ |
| 104) Responds to stimuli (internal and external) | B) muscular system | 104) _____ |

*Match the following:*

- |               |  |            |
|---------------|--|------------|
| 105) Proximal | A) close to the origin of the body part or the point of attachment of a limb to the body trunk | 105) _____ |
|---------------|--|------------|

*Match the following.*

- |                            |                    |            |
|----------------------------|--------------------|------------|
| 106) Site of hematopoiesis | A) skeletal system | 106) _____ |
|----------------------------|--------------------|------------|

*Match the following:*

- |               |                  |            |
|---------------|------------------|------------|
| 107) Patellar | A) armpit        | 107) _____ |
| 108) Axillary | B) anterior knee | 108) _____ |

*Match the following:*

- |           |                               |            |
|-----------|-------------------------------|------------|
| 109) Deep | A) toward the body surface    | 109) _____ |
|           | B) away from the body surface |            |

*Match the following:*

- |              |          |            |
|--------------|----------|------------|
| 110) Femoral | A) thigh | 110) _____ |
|--------------|----------|------------|

*Match the following:*

- |             |  |            |
|-------------|--|------------|
| 111) Distal | A) farther from the origin of a body part or the point of attachment of a limb to the body trunk | 111) _____ |
|-------------|--|------------|

Match the following:

112) Coxal

A) hip

112) \_\_\_\_\_

Match the following.

113) Houses blood cells involved in immunity

A) lymphatic system

113) \_\_\_\_\_

B) respiratory system

Match the following:

114) Orbital

A) eye area

114) \_\_\_\_\_

Match the following:

115) Inferior

A) below

115) \_\_\_\_\_

Match the following.

116) Slow-acting body control system

A) digestive system

116) \_\_\_\_\_

B)  
endocrine system

Match the following:

117) Medial

A) toward the midline

117) \_\_\_\_\_

**ESSAY. Write your answer in the space provided or on a separate sheet of paper.**

118) Describe anatomical position. Explain why anatomical position is used.

119) Explain the difference between homeostatis and metabolism.

120) List and explain the eight necessary human life functions.

121) Explain how scratching an itch is an example of the negative feedback mechanism.

122) Describe the role of the effector in the negative feedback system.

123) List, and briefly define, the human body's organization levels from smallest to largest.

124) List and explain the three major body planes and sections.

125) Distinguish between *anatomy* and *physiology*.

126) Identify the two dorsal body cavities, and state their locations and the organs contained therein.

127) List the four quadrants and nine regions of the abdominopelvic cavity. Explain why this cavity has these subdivisions.

128) List and explain the five survival needs of humans.



- 1) A
- 2) C
- 3) B
- 4) C
- 5) D
- 6) D
- 7) E
- 8) E
- 9) A
- 10) B
- 11) C
- 12) D
- 13) B
- 14) B
- 15) A
- 16) A
- 17) C
- 18) A
- 19) A
- 20) D
- 21) D
- 22) E
- 23) B
- 24) C
- 25) C
- 26) C
- 27) B
- 28) B
- 29) D
- 30) D
- 31) A
- 32) A
- 33) B
- 34) B
- 35) A
- 36) E
- 37) B
- 38) B
- 39) midsagittal or median
- 40) abdominal
- 41) negative feedback
- 42) respiratory
- 43) epigastric
- 44) homeostasis
- 45) 4; 9
- 46) ventral or anterior
- 47) Digestion
- 48) hypogastric
- 49) spinal
- 50) pelvic
- 51) anterior

- 52) tissues
- 53) cranial
- 54) mediastinum
- 55) skeletal
- 56) effector
- 57) superior
- 58) urinary or excretory
- 59) irritability; responsiveness
- 60) axillary
- 61) medial
- 62) right hypochondriac
- 63) umbilical
- 64) tissue
- 65) ventral or anterior
- 66) dorsal
- 67) endocrine
- 68) Metabolism
- 69) diaphragm
- 70) right iliac (inguinal)
- 71) microscopic anatomy
- 72) right lumbar
- 73) thoracic
- 74) hypogastric
- 75) digestion
- 76) epigastric region, umbilical region, hypogastric region
- 77) positive
- 78) FALSE
- 79) TRUE
- 80) FALSE
- 81) FALSE
- 82) TRUE
- 83) FALSE
- 84) FALSE
- 85) FALSE
- 86) FALSE
- 87) TRUE
- 88) FALSE
- 89) TRUE
- 90) FALSE
- 91) FALSE
- 92) TRUE
- 93) A
- 94) B
- 95) C
- 96) A
- 97) C
- 98) B
- 99) D
- 100) A
- 101) A
- 102) B
- 103) B

- 104) A
- 105) A
- 106) A
- 107) B
- 108) A
- 109) B
- 110) A
- 111) A
- 112) A
- 113) A
- 114) A
- 115) A
- 116) B
- 117) A

118) Anatomical position is defined as standing erect, feet parallel to the arms, palms facing forward. Anatomical position is used because it is a standard position; it also helps us to avoid confusion. Additionally, anatomical position is a reference point that helps us accurately describe body parts and position.

119) Homeostasis is the body's attempt to maintain balance during which time internal conditions may vary. Metabolism is all chemical reactions that occur in the body.

- 120) 1. Maintenance of boundaries—keeps the internal environment distinct from the external environment; membranes perform this function at the cellular level and skin performs this function for the organism.  
2. Movement—includes a change in the position of the body or the propelling of a substance (such as blood, urine, or food) through the body organs; constitutes a major role of the muscular system.  
3. Responsiveness (irritability)—the ability to react to stimuli; constitutes a major role of the nervous system.  
4. Metabolism—includes all the chemical reactions that occur within the body's cells.  
5. Excretion—elimination of carbon dioxide by the lungs and nitrogenous wastes by the kidneys.  
6. Digestion—the process of breaking down ingested foodstuffs into simpler molecules that can then be absorbed into the blood for delivery to the body's cells.  
7. Growth—an increase in size, which is usually accompanied by an increase in the number of cells.  
8. Reproduction—the production of new cells for growth and repair, and also the production of offspring.

- 121) 1. Stimulus or input is the itch.  
2. A receptor carries the information about the stimulus (itch) to the brain via an afferent pathway.  
3. Control center (brain) analyzes this information and turns on an effector which will cancel the stimulus.  
4. Information reaches the effector via the efferent pathway from the brain. Muscles move the hand to scratch the itch.  
5. Scratching continues until the itch goes away. The brain shuts off the effector once homeostasis is restored.

122) The effector is the control center's output and response to the stimulus. The effector's job is to cancel or shut off the control mechanism.

- 123) 1. chemical level:  
    a. atoms are the basic building blocks of matter  
    b. molecules are units formed by atoms combining
2. cellular level: cells are the smallest living unit in living organisms
3. tissue level: tissues are groupings of cells performing a common function
4. organ level: an organ is a structure consisting of two or more tissue types
5. organ system level: an organ system describes a group of organs functioning cooperatively for a common purpose
6. organism level: a human organism consists of all of the organ systems of the

ody working together to promote healthy functioning

b (homeostasis)

- 124) 1. Sagittal—cut is made along the longitudinal (lengthwise) plane of the body (or an organ), dividing it into right and left parts.  
2. Frontal (coronal)—cut is made along the longitudinal (lengthwise) plane of the body (or an organ), dividing it into anterior and posterior parts.  
3. Transverse (cross-section)—cut is made along the transverse (horizontal) plane, dividing the body into superior and inferior parts.
- 125) Anatomy is the study of the structure and shape of the body and body parts, and their relationships to one another. Physiology is the study of how the body and its parts work or function.
- 126) 1. Cranial cavity—the superior posterior space inside the bony skull that houses the brain.  
2. Spinal cavity—the inferior posterior space inside the bony vertebral column that houses the spinal cord.
- 127) 1. The four quadrants are:  
a. right upper quadrant  
b. right lower quadrant  
c. left upper quadrant  
d. right lower quadrant  
2. The nine regions are:  
a. epigastric region  
b. umbilical region  
c. hypogastric region  
d. right hypochondriac region  
e. left hypochondriac region  
f. right lumbar region  
g. left lumbar region  
h. right iliac region  
i. left iliac region

This cavity has been subdivided into these quadrants and regions because it is large and has many organs.

- 128) 1. Nutrients—include carbohydrates, proteins, and fats, which are taken in via the diet for energy and cell building.  
2. Oxygen—required to release energy from food.  
3. Water—accounts for over 60% of the body weight, and provides the basis for various body fluids.  
4. Appropriate body temperature—when too high or too low, physiological activities cease, primarily because molecules are destroyed or become nonfunctional.  
5. Appropriate atmospheric pressure—the force exerted on the surface of the body by the weight of air; is essential for normal operation of the respiratory system and breathing.

Exam

Name \_\_\_\_\_

**MULTIPLE CHOICE. Choose the one alternative that best completes the statement or answers the question.**

- 1) Ninety-six percent of the human body is composed of the elements: 1) \_\_\_\_\_  
A) carbon, calcium, sodium, and oxygen  
B) sodium, potassium, hydrogen, and sulfur  
C) calcium, magnesium, potassium, and iron  
D) carbon, oxygen, iron, and potassium  
E) carbon, oxygen, hydrogen, and nitrogen
- 2) Triglycerides: 2) \_\_\_\_\_  
A) include cholesterol, bile salts, vitamin D, sex hormones, and adrenal cortical hormones  
B) have a three-dimensional structure that can be easily destroyed by heat, causing them to be denatured and no longer capable of performing their physiological roles  
C) are found in fat deposits (e.g., subcutaneous tissue around organs), and serve to protect and insulate body organs; they are the major source of stored energy in the body  
D) are found in the cell membrane and participate in the transport of lipids in plasma; they are also abundant in the brain and in nervous tissue where they help to form insulating white matter  
E) include lipid substances such as fat-soluble vitamins (e.g., vitamins A, E, and K), prostaglandins, and lipoproteins
- 3) Enzymes: 3) \_\_\_\_\_  
A) increase the rates of chemical reactions by at least a millionfold  
B) are essential to virtually every biochemical reaction in the body  
C) when absent or destroyed, cause all biochemical reactions to cease  
D) help regulate growth and development  
E) are highly specialized proteins that recognize, bind with, and inactivate bacteria, toxins, and some viruses
- 4) The simplest atom—containing one proton, one electron, and no neutrons—is: 4) \_\_\_\_\_  
A) hydrogen      B) nitrogen      C) carbon      D) sodium      E) oxygen
- 5) An atom that has lost two electrons is called a(n): 5) \_\_\_\_\_  
A) isotope  
B) proton  
C) radioisotope  
D) cation  
E) anion
- 6) An atom with 11 protons, 12 neutrons, and 10 electrons is a(n): 6) \_\_\_\_\_  
A) anion  
B) cation  
C) isotope  
D) molecule  
E) radioisotope
- 7) In order to break a disaccharide down into simple sugar units: 7) \_\_\_\_\_  
A) water molecules and carbon atoms must be removed from each bond  
B) carbon atoms must be added to each bond  
C) water molecules must be removed from each bond

- D) carbon atoms must be removed from each bond
- E) water molecules must be added to each bond

8) Which of the following statements is correct regarding the electrical charge of subatomic particles: 8) \_\_\_\_\_

- A) protons are positively charged, electrons are negatively charged, and neutrons are neutral
- B) protons are positively charged, electrons are neutral, and neutrons are negatively charged
- C) protons are negatively charged, electrons are neutral, and neutrons are negatively charged
- D) protons are neutral, electrons are negatively charged, and neutrons are positively charged
- E) protons are negatively charged, electrons are positively charged, and neutrons are neutral

9) Which of the following substances below is matched with its correct organic group: 9) \_\_\_\_\_

- A) steroids - carbohydrates
- B) enzymes - proteins
- C) DNA - lipids
- D) monosaccharides - nucleic acids
- E) glycerol - proteins

10) Which of the following is the role of magnesium: 10) \_\_\_\_\_

- A) it is the major extracellular cation in its ionic form, and is important for water balance, conduction of nerve impulses, and muscle contraction
- B) it is a major extracellular anion in its ionic form
- C) it is present in bone, and is an important cofactor for enzyme activity in a number of metabolic reactions
- D) it is a component of the functional hemoglobin molecule that transports oxygen within red blood cells, as well as a component of some enzymes
- E) it is needed to make functional thyroid hormones

11) The organic compounds that function in building tissues and acting as enzymes are the: 11) \_\_\_\_\_

- A) salts
- B) lipids
- C) proteins
- D) carbohydrates
- E) nucleic acids

12) Which one of the following DNA bases are complementary: 12) \_\_\_\_\_

- A) adenine and guanine
- B) adenine and thymine
- C) cytosine and adenine
- D) guanine and uracil
- E) thymine and guanine

13) Atomic mass is equivalent to the number of \_\_\_\_\_ in an atom. 13) \_\_\_\_\_

- A) protons
- B) neutrons
- C) protons and electrons
- D) protons and neutrons
- E) electrons

14) Isotopes have different numbers of \_\_\_\_\_; thus they also have different \_\_\_\_\_. 14) \_\_\_\_\_

- A) neutrons; atomic masses
- B) electrons; atomic numbers

- C) protons; atomic masses
- D) neutrons; atomic numbers
- E) protons; atomic numbers

15) Inactive energy is referred to as:

15) \_\_\_\_\_

- A) mechanical energy
- B) electrical energy
- C) radiant energy
- D) potential energy
- E) kinetic energy

16) Which of the following groups of chemicals includes ONLY monosaccharides:

16) \_\_\_\_\_

- A) maltose, sucrose, lactose
- B) glucose, fructose, maltose
- C) fructose, maltose, lactose
- D) glucose, fructose, galactose
- E) fructose, maltose, sucrose

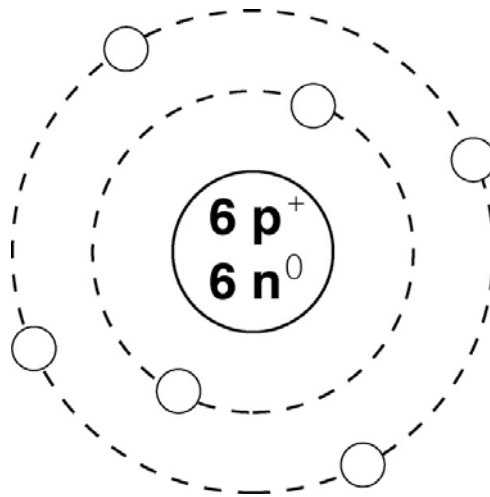

Figure 2.2

17) What is the atomic number of the atom in Figure 2.2:

17) \_\_\_\_\_

- A) 6
- B) 2
- C) 12
- D) 3
- E) 4

18) Which of the following statements about ATP is false:

18) \_\_\_\_\_

- A) it provides the energy needed to drive energy-absorbing chemical reactions
- B) it drives the transport of certain solutes (e.g., amino acids) across cell membranes
- C) its energy is captured in high-energy hydrogen bonds
- D) it activates contractile proteins in muscle cells so that cells can shorten and perform mechanical work
- E) it is a modified nucleotide

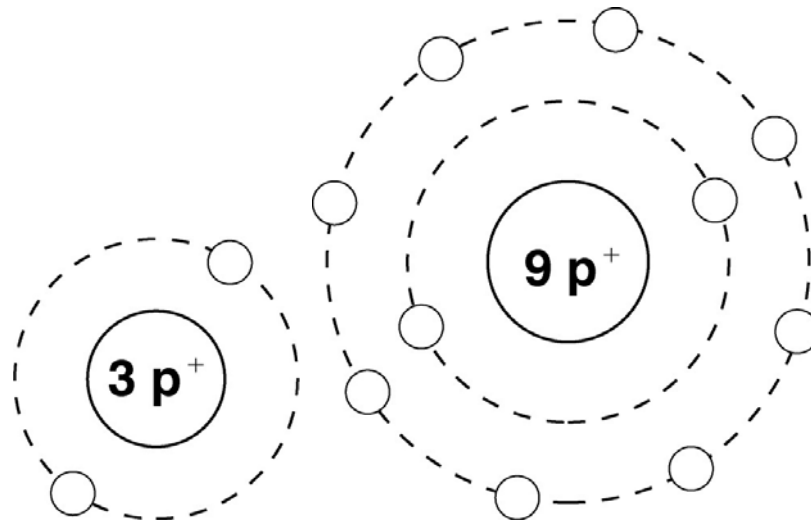

Figure 2.3

- 19) What type of chemical bond is pictured in Figure 2.3: 19) \_\_\_\_\_  
 A) single covalent bond  
 B) nonpolar covalent bond  
 C) double covalent bond  
 D) polar covalent bond  
 E) ionic bond
- 20) Glycogen is the storage form of \_\_\_\_\_ in animals. 20) \_\_\_\_\_  
 A) glucose  
 B) lipids  
 C) DNA  
 D) protein  
 E) amino acids
- 21) Vitamin D and sex hormones are both: 21) \_\_\_\_\_  
 A) nucleic acids  
 B) steroids  
 C) proteins  
 D) polysaccharides  
 E) enzymes
- 22) Which of these examples is a compound: 22) \_\_\_\_\_  
 A) CH<sub>4</sub>      B) N<sub>2</sub>      C) 2H      D) H<sub>2</sub>      E) O<sub>2</sub>
- 23) When a pair of electrons is shared equally between two atoms, the bond formed is called a(n): 23) \_\_\_\_\_  
 A) ionic bond  
 B) hydrogen bond  
 C) polar covalent bond  
 D) nonpolar covalent bond  
 E) carbon bond
- 24) The reaction  $A + B \rightarrow AB$  is an example of a(n): 24) \_\_\_\_\_  
 A) decomposition reaction  
 B) dehydration reaction  
 C) synthesis reaction



- D) denaturation reaction
- E) exchange reaction

- 25) A solution with a pH of 7: 25) \_\_\_\_\_  
A) releases more hydrogen ions than hydroxyl ions into solution  
B) is acidic  
C) releases more hydroxyl ions than hydrogen ions into solution  
D) is basic  
E) is neutral
- 26) The nucleotide chains of DNA are held together by: 26) \_\_\_\_\_  
A) hydrogen bonds  
B) carbon bonds  
C) polar covalent bonds  
D) nonpolar covalent bonds  
E) ionic bonds
- 27) Which of these elements composes bone: 27) \_\_\_\_\_  
A) calcium          B) chlorine          C) sulfur          D) iodine          E) iron
- 28) The most abundant element in the human body is: 28) \_\_\_\_\_  
A) carbon          B) nitrogen          C) oxygen          D) calcium          E) hydrogen
- 29) The sugar found in DNA is: 29) \_\_\_\_\_  
A) deoxyribose  
B) lactose  
C) starch  
D) ribose  
E) sucrose
- 30) \_\_\_\_\_ are simple sugars containing between 3 and 7 carbon atoms. 30) \_\_\_\_\_  
A) Steroids  
B) Proteins  
C) Polysaccharides  
D) Saturated fats  
E) Monosaccharides
- 31) Which of the following statements about RNA is true: 31) \_\_\_\_\_  
A) RNA is composed of cytosine, guanine, adenine, and thymine  
B) RNA is single stranded  
C) RNA is found only in the nucleus of the cell  
D) RNA contains deoxyribose  
E) RNA is a double helix
- 32) Vitamin D can be described as: 32) \_\_\_\_\_  
A) derivatives of fatty acids found in cell membranes; various functions include the stimulation of uterine contractions, the regulation of blood pressure, and the control of motility of the gastrointestinal tract  
B) taken in via plant products such as wheat germ and green leafy vegetables; may promote wound healing and contribute to fertility (though not proven in humans)  
C) made available largely by the action of intestinal bacteria; also prevalent in a wide variety of foods, and necessary for the proper clotting of blood

- D) produced in the skin on exposure to UV radiation; necessary for normal bone growth and function
- E) a constituent of orange-pigmented vegetables (carrots) and fruits (tomatoes), and part of the photoreceptor pigment involved in vision

- 33) The movement of ions across cell membranes is an example of: 33) \_\_\_\_\_
- A) potential energy
  - B) radiant energy
  - C) mechanical energy
  - D) electrical energy
  - E) chemical energy
- 34) Shell 1 of an atom can hold a maximum of \_\_\_\_\_ electron(s). 34) \_\_\_\_\_
- A) 1
  - B) 2
  - C) 4
  - D) 8
  - E) 18
- 35) The subatomic particles that are responsible for the chemical behavior of atoms are the: 35) \_\_\_\_\_
- A) electrons
  - B) neutrons
  - C) protons
  - D) ions
  - E) isotopes
- 36) Carbohydrates are built up from their basic building blocks by the: 36) \_\_\_\_\_
- A) removal of a carbon atom
  - B) addition of a water molecule between each unit
  - C) removal of a water molecule between every two units
  - D) addition of a carbon atom
  - E) process termed "hydrolysis"
- 37) Which of the following solutions is the weakest acid: 37) \_\_\_\_\_
- A) a solution with a pH of 8.6
  - B) a solution with a pH of 5.2
  - C) a solution with a pH of 2.4
  - D) a solution with a pH of 6.4
  - E) a solution with a pH of 10.1
- 38) An atom with an atomic number of 14 will have \_\_\_\_\_ electrons in its valence shell. 38) \_\_\_\_\_
- A) 2
  - B) 4
  - C) 8
  - D) 10
  - E) 14
- 39) An atom has 6 protons, 8 neutrons, and 6 electrons. Its atomic mass is: 39) \_\_\_\_\_
- A) 20
  - B) 2
  - C) 14
  - D) 6
  - E) 8
- 40) The joining of amino acids to form a protein is an example of: 40) \_\_\_\_\_
- A) a hydrolysis reaction
  - B) a decomposition reaction
  - C) a synthesis reaction
  - D) an exchange reaction
  - E) a denaturation reaction
- 41) Enzymes are classified as: 41) \_\_\_\_\_
- A) triglycerides
  - B) antibodies
  - C) structural proteins
  - D) functional proteins
  - E) hormones

- 42) The atomic number of an atom reveals the number of: 42) \_\_\_\_\_  
A) neutrons plus electrons  
B) protons plus electrons  
C) protons in the atomic nucleus  
D) protons plus neutrons  
E) electrons in the atomic nucleus
- 43) Water is useful in body processes because: 43) \_\_\_\_\_  
A) it is a product in hydrolysis reactions  
B) it is a good solvent  
C) it acts as an enzyme  
D) it has a low heat capacity  
E) it is chemically inert
- 44) Glucose and starch are examples of: 44) \_\_\_\_\_  
A) proteins  
B) triglycerides  
C) carbohydrates  
D) steroids  
E) phospholipids
- 45) Which of the following is an example of an inorganic molecule: 45) \_\_\_\_\_  
A) an amino acid  
B) RNA  
C) cholesterol  
D) sodium chloride  
E) a fatty acid
- 46) Which of these factors will not *increase* the rate of a chemical reaction: 46) \_\_\_\_\_  
A) increased temperature  
B) increased concentration of reacting particles  
C) decrease in particle size  
D) presence of catalysts  
E) decreased temperature
- 47) Trans fats are oils that have been solidified by the addition of: 47) \_\_\_\_\_  
A) hydrogen atoms  
B) oxygen atoms  
C) phosphorus-containing groups  
D) nitrogen atoms  
E) carbon atoms
- 48) Which of the following statements about enzymes is true: 48) \_\_\_\_\_  
A) they are carbohydrates  
B) they are required in large amounts in order to be effective  
C) they are biological catalysts  
D) they are not reuseable  
E) they are stable at high temperatures
- 49) Which of these substances is an enzyme: 49) \_\_\_\_\_  
A) glucose  
B) omega-3 fatty acid

- C) triglyceride
- D) oxidase
- E) nucleotide

50) Saturated fats:

50) \_\_\_\_\_

- A) are formed from 4 interlocking carbon rings
- B) exist as liquids and are derived from plants
- C) contain many double bonds
- D) exist as solids at room temperature
- E) have two fatty acid chains

**SHORT ANSWER. Write the word or phrase that best completes each statement or answers the question.**

51) Describe the role of the electron in chemical bond formation.

51) \_\_\_\_\_

*Fill in the blank or provide a short answer:*

52) Isotopes differ from each other only in the number of \_\_\_\_\_ they possess.

52) \_\_\_\_\_

53) All \_\_\_\_\_ have an amine ( $NH_2$ ) group.

53) \_\_\_\_\_

54) An acid is a molecule that releases (donates) \_\_\_\_\_. State the answer in two ways.

54) \_\_\_\_\_

55) Compounds that contain carbon-hydrogen bonding are collectively termed \_\_\_\_\_ compounds.

55) \_\_\_\_\_

56) Decomposition of a protein produces \_\_\_\_\_.

56) \_\_\_\_\_

57) The outermost shell of an atom is called the \_\_\_\_\_ shell.

57) \_\_\_\_\_

58) The building blocks of nucleic acids are called \_\_\_\_\_.

58) \_\_\_\_\_

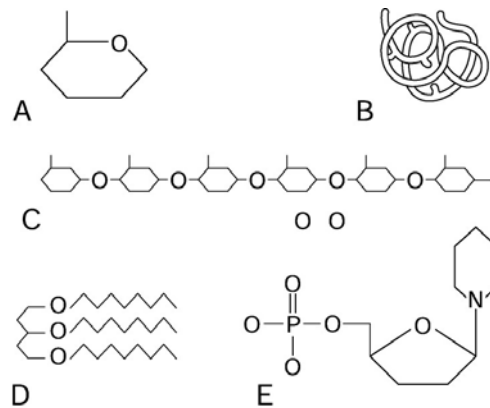

Figure 2.1

*Using Figure 2.1, identify the following:*

59) The structure of the polysaccharide is \_\_\_\_\_.

59) \_\_\_\_\_

*Fill in the blank or provide a short answer:*

60) The universal energy compound that provides visible energy to cells is \_\_\_\_\_.

60) \_\_\_\_\_

61) Glycogen and starch are examples of a specific category of carbohydrates called \_\_\_\_\_.

61) \_\_\_\_\_

- 62) A solution with a pH of 11.7 is \_\_\_\_\_ times more acidic than a solution with a pH of 8.7. 62) \_\_\_\_\_
- 63) Enzymes are examples of \_\_\_\_\_ proteins. State the answer in two ways. 63) \_\_\_\_\_

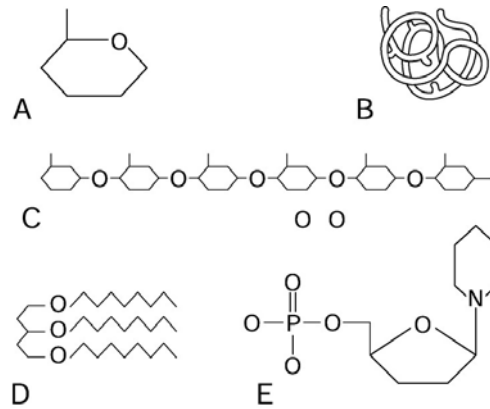

Figure 2.1

Using Figure 2.1, identify the following:

- 64) The structure of the monosaccharide is \_\_\_\_\_. 64) \_\_\_\_\_

Fill in the blank or provide a short answer:

- 65) Polar molecules, like water, result when electrons are shared \_\_\_\_\_. 65) \_\_\_\_\_

- 66) When a change in matter alters the basic nature of the substance, it is called a \_\_\_\_\_ change. 66) \_\_\_\_\_

- 67) Cholesterol is an example of a \_\_\_\_\_, a specific category of lipids. 67) \_\_\_\_\_

- 68) Inactive or stored energy is called \_\_\_\_\_ energy. 68) \_\_\_\_\_

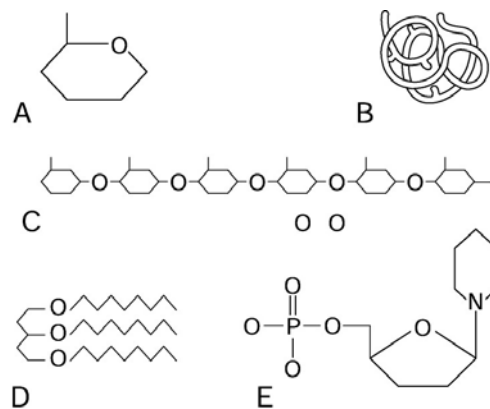

Figure 2.1

Using Figure 2.1, identify the following:

- 69) The structure of the functional protein is \_\_\_\_\_. 69) \_\_\_\_\_

- 70) The structure of the nucleotide is \_\_\_\_\_. 70) \_\_\_\_\_

Fill in the blank or provide a short answer:

71) The sum of the protons and neutrons in an atom is called the \_\_\_\_\_. 71) \_\_\_\_\_

**TRUE/FALSE. Write 'T' if the statement is true and 'F' if the statement is false.**

72) Atoms are the smallest particles of a compound that still retain the properties of that compound. 72) \_\_\_\_\_

73) Negatively charged atoms are called cations. 73) \_\_\_\_\_

74) Every atom in a molecule has a full valence shell. 74) \_\_\_\_\_

75) Water is the single most abundant inorganic compound in the human body. 75) \_\_\_\_\_

76) Inactive or stored energy is called kinetic energy. 76) \_\_\_\_\_

77) When a solution produces equal numbers of hydrogen and hydroxyl ions, it is said to be neutral. 77) \_\_\_\_\_

78) Stored energy is called potential energy. 78) \_\_\_\_\_

79) Estrogen and cholesterol are both steroids. 79) \_\_\_\_\_

80) Carbon is found in all inorganic compounds. 80) \_\_\_\_\_

81) The lower the pH, the greater the number of hydrogen ions. 81) \_\_\_\_\_

82) The normal pH of blood occupies a narrow range around 7.35–7.45. 82) \_\_\_\_\_

83) Enzymes decrease the rates of chemical reactions. 83) \_\_\_\_\_

84) Calcium is one of the major elements composing the human body. 84) \_\_\_\_\_

85) Disruption of the hydrogen bonds of functional proteins leads to their denaturation. 85) \_\_\_\_\_

86) Compounds that ionize completely, producing large numbers of hydrogen ions (protons), are termed *weak bases*. 86) \_\_\_\_\_

**MATCHING. Choose the item in column 2 that best matches each item in column 1.**

Match the following:

87) Nucleotides form the building blocks of these organic compounds      A) carbohydrates      87) \_\_\_\_\_

88) Glycogen, glucose, and lactose are examples of these organic compounds      B) nucleic acids      88) \_\_\_\_\_

Match the following:

89) The particle(s) contributing to the atomic number      A) proton(s)      89) \_\_\_\_\_

90) The particle(s) contributing to the atomic mass      B) protons and neutrons      90) \_\_\_\_\_

Match the following:

91) A bond in which electrons are shared unequally

A) polar covalent bond

91) \_\_\_\_\_

B) nonpolar covalent bond

Match the following:

92) The particle(s) that differ between isotopes

A) neutron(s)

92) \_\_\_\_\_

Match the following:

93) A type of bond important in holding different parts of the same molecule together in three-dimensional structure

A) polar covalent bond

93) \_\_\_\_\_

B) nonpolar covalent bond

94) Type of bond exhibited by carbon dioxide

C) double bond

94) \_\_\_\_\_

D) hydrogen bond

Match the following:

95) DNA, RNA, and ATP are types of these organic compounds

A) nucleic acids

95) \_\_\_\_\_

Match the following:

96) The number of protons is equal to the number of these subatomic particles

A) electron(s)

96) \_\_\_\_\_

Match the following:

97) Building block is the monosaccharide

A) lipids

97) \_\_\_\_\_

98) Most of this organic compound group are water insoluble

B) carbohydrates

98) \_\_\_\_\_

99) Triglycerides, steroids, and fat-soluble vitamins are types of these organic compounds

99) \_\_\_\_\_

Match the following:

100) A type of covalent bond formed when atoms share two pairs of electrons

A) ionic bond

100) \_\_\_\_\_

B) single covalent bond

*Match the following:*

101) Building blocks of these organic compounds are amino acids                      A) proteins                      101) \_\_\_\_\_

*Match the following:*

102) The particle(s) shared during covalent bond formation                      A) electron(s)                      102) \_\_\_\_\_

*Match the following:*

103) Antibodies, some hormones, and enzymes are types of these organic compounds                      A) proteins                      103) \_\_\_\_\_

*Match the following:*

104) The particle(s) lost during cation formation                      A) electron(s)                      104) \_\_\_\_\_

*Match the following:*

105) A bond in which electrons are completely lost or gained by the atoms involved                      A) covalent bond                      105) \_\_\_\_\_  
B) ionic bond

*Match the following:*

106) The particle(s) located within the nucleus                      A) protons and neutrons                      106) \_\_\_\_\_

**ESSAY. Write your answer in the space provided or on a separate sheet of paper.**

107) Explain why a denatured protein no longer functions.

108) Explain why enzymes are specific to their substrates.

109) Compare DNA and RNA from the standpoint of their location, role(s), number of chains, arrangement of nucleotides, and sugars and bases present.

110) Differentiate between a molecule and a compound.

111) Distinguish between a dehydration synthesis and a hydrolysis reaction.

112) Discuss the major properties of water that make it so vital to the proper functioning of the body.

113) Explain why hydrolysis (decomposition) reactions require the addition of water.

114) Explain why ATP is classified as a nucleic acid.



115) Explain how saturated fats are different from unsaturated fats.

116) List the three parts of a nucleotide.

117) Describe the difference between a polar and a nonpolar covalent bond. Give and explain an example of each type of bond.

118) Name this type of reaction and briefly explain what is happening in this reaction:

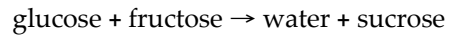

- 1) E
- 2) C
- 3) A
- 4) A
- 5) D
- 6) B
- 7) E
- 8) A
- 9) B
- 10) C
- 11) C
- 12) B
- 13) D
- 14) A
- 15) D
- 16) D
- 17) A
- 18) C
- 19) E
- 20) A
- 21) B
- 22) A
- 23) D
- 24) C
- 25) E
- 26) A
- 27) A
- 28) C
- 29) A
- 30) E
- 31) B
- 32) D
- 33) D
- 34) B
- 35) A
- 36) C
- 37) D
- 38) B
- 39) C
- 40) C
- 41) D
- 42) C
- 43) B
- 44) C
- 45) D
- 46) E
- 47) A
- 48) C
- 49) D
- 50) D

51) When the valence shell of an atom contains fewer than 8 electrons, an atom will tend to gain, lose, or share electrons

with other atoms to reach a stable state. As a result, chemical bonds such as covalent bonds or ionic bonds are formed.

- 52) neutrons
- 53) amino acids
- 54) protons; hydrogen ions
- 55) organic
- 56) amino acids
- 57) valence
- 58) nucleotides
- 59) C
- 60) ATP (adenosine triphosphate)
- 61) polysaccharides
- 62) 1000
- 63) globular; functional
- 64) A
- 65) unequally
- 66) chemical
- 67) steroids
- 68) potential
- 69) B
- 70) E
- 71) atomic mass number
- 72) FALSE
- 73) FALSE
- 74) TRUE
- 75) TRUE
- 76) FALSE
- 77) TRUE
- 78) TRUE
- 79) TRUE
- 80) FALSE
- 81) TRUE
- 82) TRUE
- 83) FALSE
- 84) FALSE
- 85) TRUE
- 86) FALSE
- 87) B
- 88) A
- 89) A
- 90) B
- 91) A
- 92) A
- 93) D
- 94) B
- 95) A
- 96) A
- 97) B
- 98) A
- 99) A
- 100) B
- 101) A
- 102) A

- 103) A
- 104) A
- 105) B
- 106) A
- 107) Denaturation results when the three-dimensional shape of a protein is destroyed. The function of a protein depends on its structure. The presence of an active site on the surface of a protein that interacts with other molecules must be intact for the enzyme to work properly.
- 108) Enzymes, like other proteins, have active sites on their surfaces that chemically interact with other molecules of complementary shape and charge. These active sites must "fit" with the substrate. Enzymes bind to the reacting substrates and structural changes result in a new product.
- 109) 1. Location—DNA is located inside the nucleus of the cell; RNA is located inside and outside the nucleus of the cell.  
2. Role(s)—DNA undergoes replication prior to cell division to pass on heredity information, and provides instructions for the building of all protein; RNA carries out the orders for protein synthesis issued by DNA.  
3. Number of chains—DNA consists of a double chain of nucleotides in the form of a double helix; RNA is a single chain of nucleotides.  
4. Arrangement of nucleotides—DNA consists of sugar and phosphate molecules that form uprights of a ladder-like structure, and each rung is formed by two joined bases; in RNA, a base projects from each sugar-phosphate unit in the chain of nucleotides.  
5. Sugar—the sugar in DNA is deoxyribose; the sugar in RNA is ribose.  
6. Bases—in DNA the bases are adenine (A), thymine (T), guanine (G) and cytosine (C); in RNA the bases are adenine (A), uracil (U), guanine (G) and cytosine (C).
- 110) Molecules are formed when two or more atoms of the same element combine chemically. Compounds result when two or more different atoms bind together to form a molecule.
- 111) In a dehydration synthesis reaction, a more complex molecule is formed from two simpler ones, and a water molecule is lost as each bond forms. An example of dehydration synthesis is seen when a disaccharide is formed from two monosaccharides. Hydrolysis is the breakdown of a more complex molecule into its building blocks. A water molecule is added to each bond, the bond is broken, and simpler molecules are formed. In the process, water is split into a hydrogen ion and a hydroxyl ion. An example of hydrolysis is seen when a disaccharide is broken down into two monosaccharides.
- 112) 1. It has a high heat capacity, and absorbs and releases large amounts of heat before its temperature changes appreciably. Therefore, it helps maintain homeostatic body temperature.  
2. Because of its polarity, it is an excellent solvent in which electrolytes can ionize. Nutrients, respiratory gases, and wastes can dissolve in water, thereby allowing water to act as a transport and exchange medium in the body. Water is also used as a solvent in specialized molecules that lubricate the body, such as mucus that eases the movement of feces in the digestive tube, saliva that moistens food and prepares it for digestion, and synovial fluids that lubricate bone ends.  
3. Water is a reactant in some types of chemical reactions, such as digestion and the breakdown of large biological molecules. Water is added to the bonds of the larger molecules in specific reactions termed hydrolysis reactions.  
4. Water serves a protective function by forming a watery cushion (e.g., cerebrospinal fluid cushions the brain and amniotic fluid cushions the fetus).
- 113) Water molecules are added to the bonds of large organic molecules. When water is added to each bond, the bond is broken, and the molecule is broken down.
- 114) ATP is a modified nucleotide. Nucleotides are the building blocks of nucleic acids. ATP consists of a base (adenine), a sugar (ribose), and three phosphate groups.
- 115) Saturated fats:
1. tend to be animal fats
  2. have all single bonds between carbon atoms
  3. may be solid
- Unsaturated fats:
1. tend to be plant oils
  2. have some double or triple bonds between carbon atoms
  3. may be liquid

116) Nucleotides contain:

1. a nitrogen-containing base
2. a pentose (5-carbon) sugar
3. a phosphate group

117) 1. In polar covalent bonds, electrons are not shared equally. For instance, water is an example of a polar covalent bond. The electron pairs shared in water spend more time with the oxygen atom causing that end of the molecule to become slightly negative and the hydrogen end to become slightly positive.

2. In nonpolar covalent bonds, electrons are shared equally. For example, the electron pairs in carbon dioxide orbit the entire molecule.

118) Glucose and fructose are two monosaccharides. Sucrose is a disaccharide. Glucose and fructose are combining to form sucrose. This is an example of a dehydration synthesis reaction. A water molecule is lost from the two simple sugars as the bond forms to create the double sugar.

Exam  
Name \_\_\_\_\_

**MULTIPLE CHOICE. Choose the one alternative that best completes the statement or answers the question.**

- 1) Which of the following is NOT connective tissue: 1) \_\_\_\_\_
- A) skeletal muscle
  - B) cartilage
  - C) bone
  - D) adipose
  - E) blood

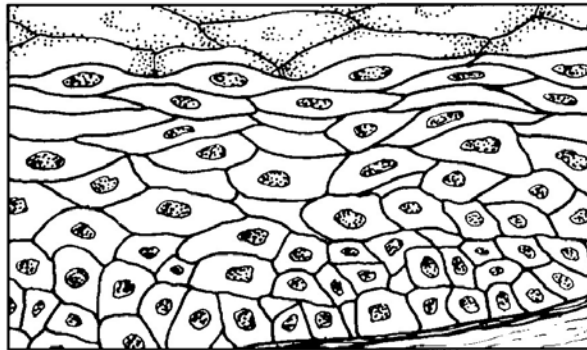

Figure 3.3

- 2) The tissue shown in Figure 3.3 most likely: 2) \_\_\_\_\_
- A) transmits electrochemical impulses
  - B) stores fat
  - C) covers and lines body surfaces
  - D) contracts to produce movement
  - E) contains a matrix
- 3) Which type of tissue conducts electrochemical impulses: 3) \_\_\_\_\_
- A) nervous tissue
  - B) connective tissue
  - C) muscle tissue
  - D) dense tissue
  - E) epithelial tissue
- 4) Goblet cells are found in: 4) \_\_\_\_\_
- A) stratified squamous epithelium
  - B) simple squamous epithelium
  - C) simple cuboidal epithelium
  - D) transitional epithelium
  - E) simple columnar epithelium
- 5) The type of muscle found in the walls of hollow organs, such as the stomach, and in the walls of blood vessels is: 5) \_\_\_\_\_
- A) both smooth muscle and skeletal muscle
  - B) smooth muscle
  - C) skeletal muscle
  - D) cardiac muscle
  - E) both cardiac muscle and skeletal muscle

- 6) The molecule that carries an amino acid to the ribosome for incorporation into a protein is: 6) \_\_\_\_\_  
A) messenger RNA (mRNA)  
B) transfer RNA (tRNA)  
C) DNA  
D) ATP  
E) ribosomal RNA (rRNA)
- 7) The site where ribosomes assemble prior to their migration into the cytoplasm is the: 7) \_\_\_\_\_  
A) plasma membrane  
B) chromatin  
C) chromosomes  
D) nuclear membrane  
E) nucleolus
- 8) Which cell structure forms an internal framework inside the cell and is made of microtubules, intermediate filaments, and microfilaments: 8) \_\_\_\_\_  
A) nucleus  
B) plasma membrane  
C) mitochondria  
D) cytoplasm  
E) cytoskeleton
- 9) The tissue that is usually well vascularized and has an extensive extracellular matrix is called: 9) \_\_\_\_\_  
A) connective tissue  
B) brain tissue  
C) nervous tissue  
D) muscle tissue  
E) epithelial tissue
- 10) Which of the following do not involve the movement of molecules from an area of greater concentration to an area of lower concentration: 10) \_\_\_\_\_  
A) simple diffusion  
B) facilitated diffusion  
C) diffusion  
D) osmosis  
E) filtration
- 11) Two types of passive transport are: 11) \_\_\_\_\_  
A) endocytosis and diffusion  
B) exocytosis and endocytosis  
C) diffusion and filtration  
D) osmosis and endocytosis  
E) filtration and exocytosis
- 12) The three major components of the cytoplasm are the: 12) \_\_\_\_\_  
A) cytosol, organelles, and inclusions  
B) cytosol, inclusions, and nucleoli  
C) organelles, inclusions, and ribosomes  
D) organelles, inclusions, and nucleoli  
E) cytosol, organelles, and nucleoli

- 13) The type of tissue with a matrix that consists of rows of fibroblasts that manufacture collagen fibers is: 13) \_\_\_\_\_
- A) adipose tissue
  - B) areolar tissue
  - C) loose connective tissue
  - D) osseous tissue
  - E) dense connective tissue
- 14) A patient arrives in the hospital extremely dehydrated. In order to fill his cells with fluid, he should be hooked to a(n) \_\_\_\_\_ intravenous drip. 14) \_\_\_\_\_
- A) hypotonic
  - B) isotonic
  - C) hypertonic
  - D) either hypertonic or hypotonic
  - E) either isotonic or hypertonic
- 15) A solution that contains fewer solutes than the cell is: 15) \_\_\_\_\_
- A) intravenous
  - B) hypertonic
  - C) hypotonic
  - D) Ringer's lactate
  - E) isotonic
- 16) DNA replication takes place during: 16) \_\_\_\_\_
- A) prophase
  - B) interphase
  - C) metaphase
  - D) telophase
  - E) anaphase
- 17) If the sequence of nitrogenous bases in one strand of DNA is GTA-GCA, the sequence of bases on its complementary DNA strand would be: 17) \_\_\_\_\_
- A) CAT-CGT
  - B) CAU-CGU
  - C) GAU-GCU
  - D) ACG-ATT
  - E) GAT-GCT
- 18) The molecules in the cell membrane that serve as receptors or binding sites for hormones or other chemical messengers are the: 18) \_\_\_\_\_
- A) cholesterol molecules
  - B) glycoproteins
  - C) lipids
  - D) proteins
  - E) carbohydrates
- 19) Identify the type of tissue that is found in lymph nodes, the spleen, and bone marrow: 19) \_\_\_\_\_
- A) dense connective tissue
  - B) areolar tissue
  - C) osseous tissue
  - D) adipose tissue
  - E) reticular connective tissue



- 20) Cells that are specialized to fight disease are called: 20) \_\_\_\_\_  
A) macrophages  
B) epithelial cells  
C) oocytes  
D) nerve cells  
E) fibroblasts
- 21) The molecule that contains anticodons is: 21) \_\_\_\_\_  
A) ribosomal RNA (rRNA)  
B) transfer RNA (tRNA)  
C) DNA  
D) messenger RNA (mRNA)  
E) ATP
- 22) The DNA segment that carries information coding for a particular amino acid is a: 22) \_\_\_\_\_  
A) gene  
B) nucleotide  
C) phosphate group  
D) deoxyribose sugar  
E) triplet
- 23) Which type of epithelial tissue is found lining kidney tubules: 23) \_\_\_\_\_  
A) simple columnar  
B) simple cuboidal  
C) simple squamous  
D) pseudostratified columnar  
E) stratified squamous
- 24) Perform transcription on this partial sequence of DNA into mRNA: TTA-GCT-ACT 24) \_\_\_\_\_  
A) GGC-TAG-TAG  
B) AAT-CGA-TGA  
C) UUT-CGU-TGU  
D) UUA-CGU-AGU  
E) AAU-CGA-UGA
- 25) The last step in the process of tissue regeneration is: 25) \_\_\_\_\_  
A) scab formation  
B) surface epithelium regenerates  
C) granulation tissue forms  
D) blood clot forms  
E) capillaries become very permeable
- 26) The phase of cell division during which the chromatids are pulled apart and move to the opposite ends of the cell is: 26) \_\_\_\_\_  
A) telophase  
B) interphase  
C) prophase  
D) metaphase  
E) anaphase
- 27) Glands, such as the thyroid, that secrete their products directly into the blood rather than through

ducts are 27)  
classified  
as:

—  
—

- A) ceruminous
- B) sebaceous
- C) endocrine
- D) sudoriferous
- E) exocrine

28) Fat is:

28) \_\_\_\_\_

- A) adipose tissue
- B) loose connective tissue
- C) osseous tissue
- D) areolar tissue
- E) dense connective tissue

29) A cancer drug interferes with the development of mitotic spindle fibers during cell division.  
Which phase is directly affected:

29) \_\_\_\_\_

- A) interphase
- B) telophase
- C) metaphase
- D) prophase
- E) anaphase

30) A cell whose job is to detoxify harmful or poisonous substances such as alcohol would have  
many:

30) \_\_\_\_\_

- A) peroxisomes
- B) lysosomes
- C) rough endoplasmic reticulum
- D) nuclei
- E) flagella

31) Which of the following statements about DNA is incorrect:

31) \_\_\_\_\_

- A) it contains 2 chains
- B) it has the base uracil instead of thymine
- C) it contains deoxyribose sugars
- D) it is replicated in preparation for cell division
- E) it never leaves the nucleus

32) Microvilli are apt to be found in cells that are specialized for:

32) \_\_\_\_\_

- A) division
- B) contraction
- C) absorption
- D) insulation
- E) protection

33) The movement of fluid through the cell membrane from a high pressure area to a lower pressure  
area is called:

33) \_\_\_\_\_

- A) active transport
- B) bulk transport
- C) osmosis
- D) filtration

E) diffusion

- 34) Ribosomes are found: 34) \_\_\_\_\_  
A) in the cytoplasm  
B) on the Golgi apparatus  
C) on the rough endoplasmic reticulum  
D) in the cytoplasm and on the rough endoplasmic reticulum  
E) on smooth endoplasmic reticulum
- 35) Which of the following processes require the use of carrier molecules: 35) \_\_\_\_\_  
A) osmosis and filtration  
B) filtration and cellular secretion  
C) facilitated diffusion and bulk transport  
D) bulk transport and osmosis  
E) facilitated diffusion and solute pumping
- 36) Which organelle uses molecular oxygen to convert and detoxify harmful substances such as alcohol and free radicals: 36) \_\_\_\_\_  
A) secretory vesicles  
B) lysosomes  
C) ribosomes  
D) peroxisomes  
E) Golgi apparatus
- 37) Two types of endocytosis are: 37) \_\_\_\_\_  
A) solute pumping and active transport  
B) pinocytosis and passive transport  
C) cellular secretion and solute pumping  
D) phagocytosis and pinocytosis  
E) active transport and phagocytosis
- 38) The molecule that is made during transcription is: 38) \_\_\_\_\_  
A) transfer RNA (tRNA)  
B) ATP  
C) messenger RNA (mRNA)  
D) ribosomal RNA (rRNA)  
E) DNA
- 39) Looking into a microscope, you notice cells swimming, propelled by a long tail. What cell structure must these cells have in order to be mobile: 39) \_\_\_\_\_  
A) smooth ER  
B) flagella  
C) ribosomes  
D) cytoplasm  
E) peroxisomes
- 40) The events of prophase seem to be opposite of those that occur during: 40) \_\_\_\_\_  
A) anaphase  
B) metaphase  
C) cytokinesis  
D) interphase  
E) telophase

- 41) The molecules that make the cell surface fuzzy, sticky, and sugar-rich are the: 41) \_\_\_\_\_  
A) glycoproteins  
B) lipid molecules  
C) cholesterol molecules  
D) proteins  
E) phospholipids
- 42) Which one of the following is NOT true about the cell membrane: 42) \_\_\_\_\_  
A) it allows water soluble molecules to pass through easily  
B) its lipid components are primarily phospholipids and cholesterol  
C) it consists of two lipid layers  
D) it regulates the entry and exit of cell materials  
E) it contains proteins for specialized functions
- 43) A cell ingests bacteria. What type of transport is likely responsible for this process: 43) \_\_\_\_\_  
A) filtration  
B) osmosis  
C) diffusion  
D) exocytosis  
E) endocytosis
- 44) The epithelial tissue found in areas subject to considerable friction and abuse, such as the esophagus, is: 44) \_\_\_\_\_  
A) transitional  
B) simple squamous epithelium  
C) pseudostratified columnar epithelium  
D) simple columnar epithelium  
E) stratified squamous epithelium
- 45) Which of these characteristics best describes cardiac muscle tissue: 45) \_\_\_\_\_  
A) single nucleus and spindle-shaped cells  
B) attached to the skeleton  
C) movement is involuntary and cells possess striations  
D) multinucleate and long, cylindrical cells  
E) movement is voluntary and cells possess striations
- 46) Which of the following is NOT an active transport process: 46) \_\_\_\_\_  
A) facilitated diffusion  
B) endocytosis  
C) pinocytosis  
D) phagocytosis  
E) exocytosis
- 47) What are the correct base-pairing rules for DNA: 47) \_\_\_\_\_  
A) adenine bonds to guanine and thymine bonds to cytosine  
B) adenine bonds to uracil and guanine bonds to cytosine  
C) adenine bonds to thymine and guanine bonds to cytosine  
D) adenine bonds to adenine and guanine bonds to guanine  
E) adenine bonds to cytosine and thymine bonds to guanine
- 48) The correct order of phases of the cell cycle is: 48) \_\_\_\_\_

- A) telophase, metaphase, anaphase, prophase
- B) prophase, metaphase, anaphase, telophase
- C) prophase, interphase, metaphase, anaphase, telophase
- D) metaphase, anaphase, prophase, telophase
- E) interphase, prophase, metaphase, anaphase, telophase

49) The tiny finger-like projections that increase the surface area of the cell for quicker absorption are called: 49) \_\_\_\_\_

- A) gap junctions
- B) microvilli
- C) inclusions
- D) tight junctions
- E) desmosomes

50) Facilitated diffusion requires the use of: 50) \_\_\_\_\_

- A) lysosomes
- B) protein channels or molecules
- C) Golgi apparatus
- D) ATP
- E) vacuoles

51) A cell would plump with water and possibly lyse in which of the following solutions: 51) \_\_\_\_\_

- A) isotonic
- B) hypotonic
- C) intravenous
- D) Ringer's
- E) hypertonic

**SHORT ANSWER. Write the word or phrase that best completes each statement or answers the question.**

52) The cell type found in nervous tissue is the \_\_\_\_\_. 52) \_\_\_\_\_

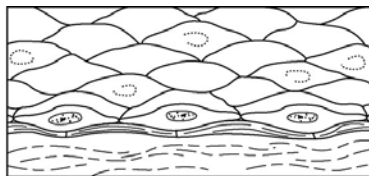

A

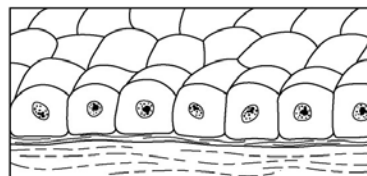

B

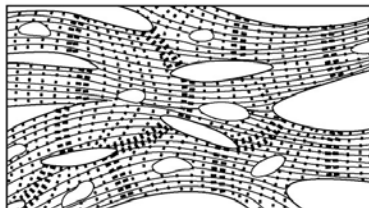

C

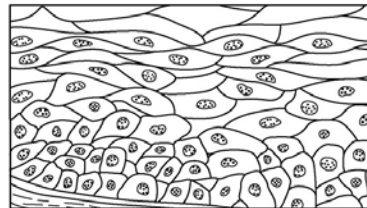

D

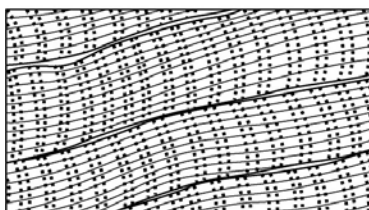

E

Figure 3.1

Using Figure 3.1, match the following:

53) The illustration of cardiac muscle tissue is \_\_\_\_\_. 53) \_\_\_\_\_

54) The type of connective tissue that contains fat stored in adipocytes is called \_\_\_\_\_. 54) \_\_\_\_\_

Fill in the blank or provide a short answer:

55) The membrane connections that prevent the leaking of fluid between cells are called \_\_\_\_\_. 55) \_\_\_\_\_

56) Whiplike cellular extensions that move substances along the cell surface are called \_\_\_\_\_. 56) \_\_\_\_\_

57) The DNA segment that carries information for building one protein or polypeptide chain is called a \_\_\_\_\_. 57) \_\_\_\_\_

58) The type of muscle tissue that can be controlled voluntarily is called \_\_\_\_\_ muscle. 58) \_\_\_\_\_

59) The phospholipid tails are \_\_\_\_\_, which make the plasma membrane impermeable to water. 59) \_\_\_\_\_

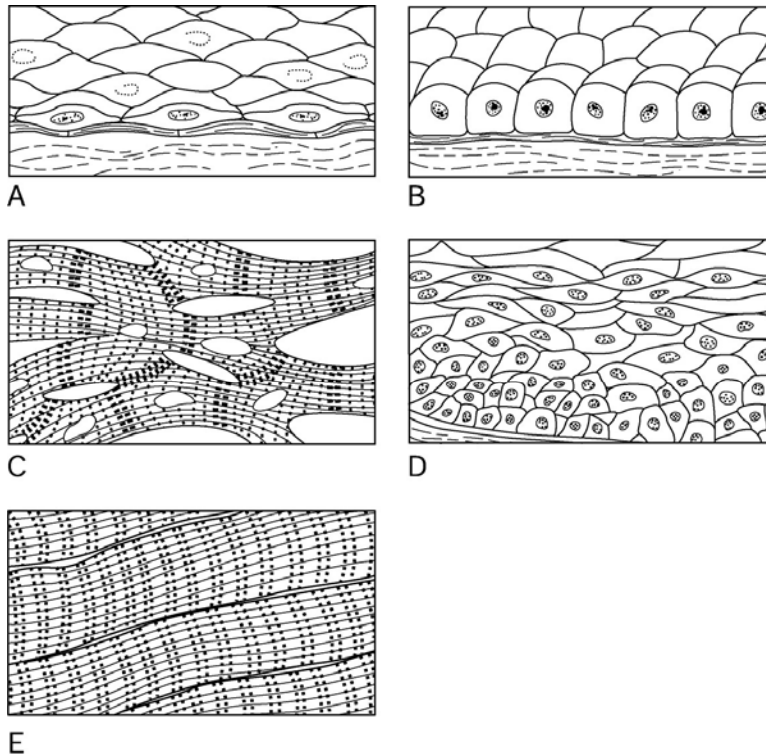

Figure 3.1

Using Figure 3.1, match the following:

60) The illustration of stratified squamous epithelium is \_\_\_\_\_. 60) \_\_\_\_\_

61) List, describe, and state the functions of the three types of membrane junctions. 61) \_\_\_\_\_

Fill in the blank or provide a short answer:

62) The specialized cellular compartments within the cytosol of the cell are collectively called \_\_\_\_\_. 62) \_\_\_\_\_

62) \_\_\_\_\_

63) The random movement of molecules (and ions) down their concentration gradient is called \_\_\_\_\_.

63) \_\_\_\_\_

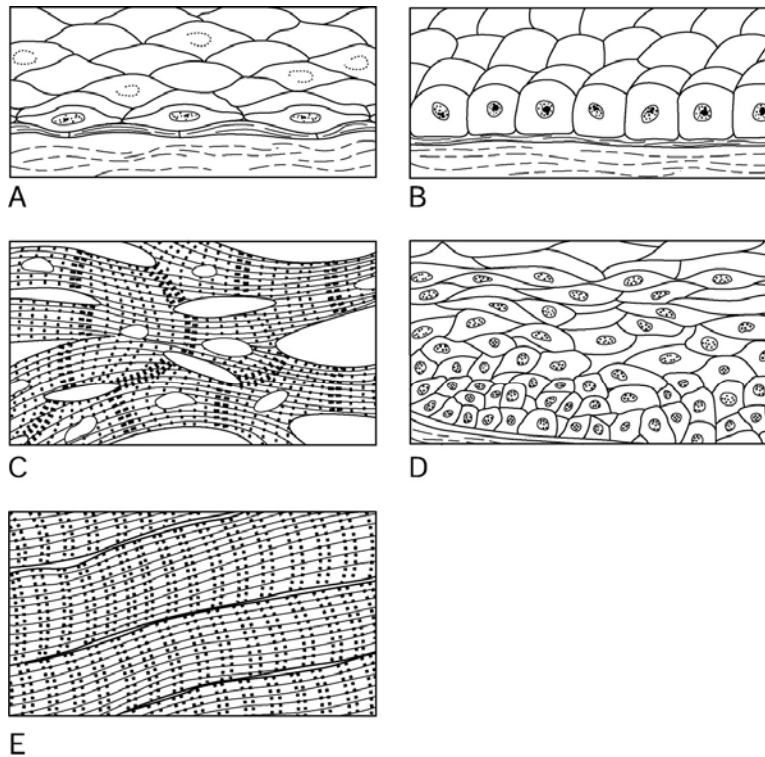

Figure 3.1

Using Figure 3.1, match the following:

64) The illustration of simple squamous epithelium is \_\_\_\_\_.

64) \_\_\_\_\_

65) The illustration of skeletal muscle tissue is \_\_\_\_\_.

65) \_\_\_\_\_

Fill in the blank or provide a short answer:

66) The step, during protein synthesis, of assembling proteins by decoding the information in messenger RNA is called \_\_\_\_\_.

66) \_\_\_\_\_

67) The rod-shaped bodies that lie at right angles to each other and internally are made up of fine microtubing called \_\_\_\_\_.

67) \_\_\_\_\_

68) After DNA replication has occurred, each of the two strands making up a chromosome is called a \_\_\_\_\_.

68) \_\_\_\_\_

69) Tiny finger-like projections of the plasma membrane that increase its surface area are called \_\_\_\_\_.

69) \_\_\_\_\_

70) Epithelial tissue consisting of one layer of cells flattened like fish scales is called a \_\_\_\_\_ epithelium.

70) \_\_\_\_\_

71) The movement of substances through the cell membrane against their concentration gradient is called \_\_\_\_\_.

71) \_\_\_\_\_

72) Many layers of cube-shaped cells should be termed \_\_\_\_\_ epithelial tissue. 72) \_\_\_\_\_

*Fill in the blank or provide a short answer:*

73) The component of a solution that is present in the smaller amount and is dissolved is the \_\_\_\_\_ 73) \_\_\_\_\_

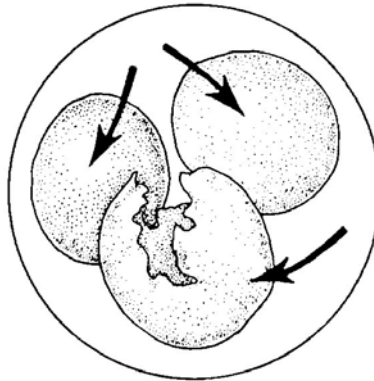

Figure 3.2

74) The cell shown in Figure 3.2 has been placed into a(n) \_\_\_\_\_ solution. 74) \_\_\_\_\_

*Fill in the blank or provide a short answer:*

75) In cell division, the term that refers to division of the cytoplasm is \_\_\_\_\_ 75) \_\_\_\_\_

76) The period of the cell cycle when the cell grows and performs its metabolic activities is \_\_\_\_\_ 76) \_\_\_\_\_

77) The type of tissue consisting of cells embedded in an extracellular matrix is \_\_\_\_\_ tissue. 77) \_\_\_\_\_

78) The network of nuclear threads, composed of DNA and protein, that condense to form chromosomes during mitosis is called \_\_\_\_\_. 78) \_\_\_\_\_



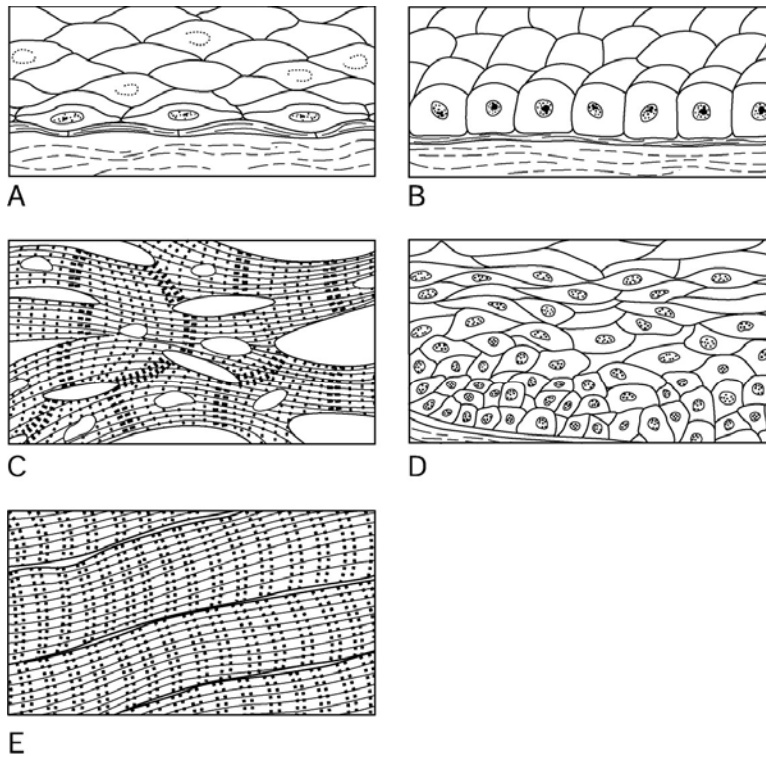

Figure 3.1

Using Figure 3.1, match the following:

79) The illustration of simple cuboidal epithelium is \_\_\_\_\_. 79) \_\_\_\_\_

Fill in the blank or provide a short answer:

80) The nucleoplasm and cytosol make up the \_\_\_\_\_ fluid. 80) \_\_\_\_\_

81) This type of epithelial tissue found lining organs of the digestive system such as the small intestines is the \_\_\_\_\_. 81) \_\_\_\_\_

82) \_\_\_\_\_ tissue contains cells called fibroblasts that make fibers such as collagen. 82) \_\_\_\_\_

83) Tendons and ligaments are common to this type of connective tissue called \_\_\_\_\_. 83) \_\_\_\_\_

**TRUE/FALSE. Write 'T' if the statement is true and 'F' if the statement is false.**

84) When a cell is placed in a hypertonic solution it will swell and may rupture. 84) \_\_\_\_\_

85) Stratified epithelium consists of one layer of epithelial cells. 85) \_\_\_\_\_

86) The nonpolar tails of the plasma membrane are hydrophobic. 86) \_\_\_\_\_

87) Protein synthesis cannot proceed without ribosomes. 87) \_\_\_\_\_

88) Translation is the stage in protein synthesis during which a complementary mRNA molecule is synthesized from a DNA template. 88) \_\_\_\_\_

89) Smooth muscle cells are uninucleated spindle-shaped cells that are voluntary. 89) \_\_\_\_\_

90) The movement of substances from an area of higher hydrostatic pressure to an area of lower hydrostatic pressure is called *diffusion*. 90) \_\_\_\_\_

- 91) The matrix of hyaline cartilage consists of abundant collagen fibers hidden in a rubbery matrix. 91) \_\_\_\_\_
- 92) The four primary tissue types are epithelium, muscle, cutaneous, and connective. 92) \_\_\_\_\_
- 93) Anaphase is the stage of cell division when the cleavage furrow first appears. 93) \_\_\_\_\_
- 94) Desmosomes are junctions that allow cell communication. 94) \_\_\_\_\_
- 95) Mitotic spindles guide the separation of chromosomes. 95) \_\_\_\_\_
- 96) The Golgi apparatus consists of a stack of flattened membranous sacs associated with swarms of tiny vesicles that are found close to the nucleus. 96) \_\_\_\_\_
- 97) The process of facilitated diffusion requires energy. 97) \_\_\_\_\_
- 98) The greater the osmotic pressure, the greater the tendency of water to move into that area. 98) \_\_\_\_\_

**MATCHING. Choose the item in column 2 that best matches each item in column 1.**

*Match the following:*

- 99) Mitochondria A) captures energy to produce ATP 99) \_\_\_\_\_

*Match the following:*

- 100) Type of tissue that consists of living cells surrounded by an extracellular matrix A) connective tissue 100) \_\_\_\_\_

*Match the following:*

- 101) Centrioles separate and move toward opposite sides of the cell A) prophase 101) \_\_\_\_\_

*Match the following:*

- 102) Lysosome A) uses oxygen to detoxify harmful substances 102) \_\_\_\_\_

- 103) Peroxisomes B) digests worn-out or nonusable cell structures 103) \_\_\_\_\_

*Match the following:*

- 104) Nucleoli appear in each daughter cell A) telophase 104) \_\_\_\_\_

*Match the following:*

- 105) Protein A) synthesized during translation 105) \_\_\_\_\_

- 106) mRNA A) synthesized during transcription and contains the codons 106) \_\_\_\_\_

*Match the following:*

107) Type of tissue whose two functional characteristics are <i>irritability</i> and <i>conductivity</i>	A) nervous tissue	107) _____
	B) connective tissue	
108) Type of tissue that can be classified as "loose" or "dense"		108) _____
<i>Match the following:</i>		
109) Ribosome	A) site of protein synthesis	109) _____
<i>Match the following:</i>		
110) Type of tissue that can be described as <i>voluntary</i> or <i>involuntary</i>	A) muscle tissue	110) _____
<i>Match the following:</i>		
111) Nucleolus	A) site of ribosome synthesis	111) _____
<i>Match the following:</i>		
112) Type of tissue that can be <i>simple</i> or <i>stratified</i>	A) epithelial tissue	112) _____
<i>Match the following:</i>		
113) Centriole	A) directs formation of mitotic spindle	113) _____
<i>Match the following:</i>		
114) Chromosomes cluster and align at the center of the spindle	A) metaphase	114) _____
<i>Match the following:</i>		
115) Microvilli	A) increases surface area of plasma membrane for absorption	115) _____
<i>Match the following:</i>		
116) Cleavage furrow squeezes the cell into two parts	A) telophase	116) _____
<i>Match the following:</i>		
117) Type of tissue that contains collagen, elastic, or reticular fibers	A) connective tissue	117) _____
<i>Match the following:</i>		
118) Centromeres split	A) anaphase	118) _____
<i>Match the following:</i>		
119) Type of tissue that has an apical surface and a basement membrane	A) epithelium	119) _____

lial tissue 119)

\_\_\_\_  
-

*Match the following:*

120) Golgi apparatus

A) packages substances for release from cell

120) \_\_\_\_

*Match the following:*

121) Nuclear envelope and nucleoid break down and disappear

A) anaphase

121) \_\_\_\_

B) prophase

122) Chromosomes move slowly apart toward opposite ends of the cell

122) \_\_\_\_

*Match the following:*

123) Type of tissue that is avascular

A) epithelial tissue

123) \_\_\_\_

*Match the following:*

124) Microtubule

A) determines overall cell shape

124) \_\_\_\_

*Match the following:*

125) tRNA

A) contains the anticodon

125) \_\_\_\_

B)

contains the anticodon and carries amino acids to the ribosome

*Match the following:*

126) Cytokinesis produces two separate daughter cells

A) telophase

126) \_\_\_\_

*Match the following:*

127) Type of tissue that consists of neurons and supporting cells

A) muscle tissue

127) \_\_\_\_

B) nervous tissue

128) Type of tissue that is specialized to contract and produce movement

128) \_\_\_\_

*Match the following:*

129) Chromosomes align at the metaphase plate

A) metaphase

129) \_\_\_\_

B) telophase

130) Spindle breaks down and disappears

130) \_\_\_\_

*Match the following:*

131) DNA

A) acts as a template during transcription

131) \_\_\_\_

B)

acts as a template during transcription and is synthesized during translation

Match the following:

132) Smooth ER

A) synthesizes cholesterol and fat

132) \_\_\_\_\_

Match the following:

133) Type of tissue that makes up  
endocrine and exocrine glands

A) epithelial tissue

133) \_\_\_\_\_

**ESSAY. Write your answer in the space provided or on a separate sheet of paper.**

134) Since epithelial tissues are avascular, explain how these tissues receive nourishment.

135) A fat-soluble vitamin, vitamin A, is moving down its concentration gradient into a cell. What type of membrane transport is responsible for its movement? Describe this process.

136) Discuss the four stages of mitosis.

137) Discuss the three steps in protein synthesis.

138) List, describe, and state the functions of the three major elements of the cytoplasm.

139) List the three different types of RNA and identify their functions.

140) Differentiate between the two types of endoplasmic reticulum.

141) Explain why an intravenous solution should be isotonic for a patient.

142) Explain the differences among the three types of muscle tissue.

143) Identify the five molecules found in the plasma membrane and state their functions.

- 1) A
- 2) C
- 3) A
- 4) E
- 5) B
- 6) B
- 7) E
- 8) E
- 9) A
- 10) E
- 11) C
- 12) A
- 13) E
- 14) A
- 15) C
- 16) B
- 17) A
- 18) D
- 19) E
- 20) A
- 21) B
- 22) E
- 23) B
- 24) E
- 25) B
- 26) E
- 27) C
- 28) A
- 29) D
- 30) A
- 31) B
- 32) C
- 33) D
- 34) D
- 35) E
- 36) D
- 37) D
- 38) C
- 39) B
- 40) E
- 41) A
- 42) A
- 43) E
- 44) E
- 45) C
- 46) A
- 47) C
- 48) E
- 49) B
- 50) B
- 51) B

- 52) neuron
- 53) C
- 54) adipose tissue
- 55) tight junctions
- 56) cilia
- 57) gene
- 58) skeletal
- 59) hydrophobic
- 60) D
- 61)
  1. Tight junctions are areas where the membranes of adjacent cells fuse together. This creates an impermeable leak-proof cellular sheet and prevents substances from passing between the cells. Tight junctions are found in epithelia lining fluid containing cavities, such as the small intestine.
  2. Desmosomes are areas where fine protein filaments extend between two adjacent cells and are anchored in button-like thickenings of the cell membranes called plaque. This type of junction holds adjacent cells together very firmly and is found in areas where cellular sheets are subjected to considerable mechanical stress, such as the skin. Within each cell, the plaques on one side are connected to plaques on the opposite side by thicker protein filaments that act to internally anchor the plaques in place.
  3. Gap junctions consist of hollow protein cylinders, called connexons, which extend completely through the plasma membrane of neighboring cells and meet and join together in the extracellular space. This creates a continuous channel for the passage of substances between the interiors of the two adjacent cells. Gap junctions, which promote intercellular communication, are found between the cardiac muscle cells in the heart.
- 62) organelles
- 63) diffusion
- 64) A
- 65) E
- 66) translation
- 67) centrioles
- 68) chromatid
- 69) microvilli
- 70) simple squamous
- 71) active transport
- 72) stratified cuboidal
- 73) solute
- 74) hypotonic
- 75) cytokinesis
- 76) interphase
- 77) connective
- 78) chromatin
- 79) B
- 80) intracellular
- 81) simple columnar
- 82) Connective
- 83) dense fibrous tissue
- 84) FALSE
- 85) FALSE
- 86) TRUE
- 87) TRUE
- 88) FALSE
- 89) FALSE
- 90) FALSE
- 91) TRUE
- 92) FALSE

- 93) TRUE
- 94) FALSE
- 95) TRUE
- 96) TRUE
- 97) FALSE
- 98) TRUE
- 99) A
- 100) A
- 101) A
- 102) B
- 103) A
- 104) A
- 105) A
- 106) B
- 107) A
- 108) B
- 109) A
- 110) A
- 111) A
- 112) A
- 113) A
- 114) A
- 115) A
- 116) A
- 117) A
- 118) A
- 119) A
- 120) A
- 121) B
- 122) A
- 123) A
- 124) A
- 125) B
- 126) A
- 127) B
- 128) A
- 129) A
- 130) B
- 131) A
- 132) A
- 133) A
- 134) Epithelial tissues depend on diffusion for food and oxygen. Capillaries in deeper connective tissue carry this nourishment.
- 135) Vitamin A is moving via simple diffusion, a type of passive transport. Passive transport requires no energy input from the cell. Vitamin A is moving from an area where it is more concentrated to an area where it is less concentrated. This vitamin is moving without assistance through the plasma membrane.
- 136) 1. Prophase—chromatin threads coil and shorten so that visible bar-like bodies, called chromosomes, appear. Each chromosome is made up of two strands, called chromatids, which are held together by a centromere. Additionally, the centrioles separate and move toward opposite sides of the cell, directing the assembly of the mitotic spindle (composed of microtubules) between them as they move.  
2. Metaphase—the chromosomes cluster and align in the center of the spindle, midway between the centrioles, forming a straight line of chromosomes.



3. Chromosomes split and the chromosomes move slowly apart toward opposite ends of the cell. A cleavage furrow appears over the midline of the spindle and eventually pinches the cytoplasmic mass into two parts in a process called cytokinesis.
4. Telophase—the chromosomes reach opposite ends of the cell and their movement ends, and they then uncoil and become chromatin again. A nuclear membrane then forms around each chromatin mass, the spindle breaks down and disappears, and nucleoli re-appear in each of the daughter nuclei. Finally, cytokinesis produces two separate daughter cells.
- 137) 1. Uncoiling of DNA—the DNA segment or gene that specifies one polypeptide or protein uncoils.  
 2. Transcription (DNA-directed synthesis of mRNA)—one strand of DNA acts as a template for the synthesis of the complementary mRNA molecule, and there is a transfer of information from the DNA's base sequence (code) into the complementary base sequence of mRNA (codon).  
 3. Translation (RNA-directed synthesis of a polypeptide or protein) involves five steps. First, mRNA leaves the nucleus and attaches to ribosomes. Second, tRNA (anticodon) transports an amino acid to the mRNA strand and recognizes a mRNA molecule (codon). Third, the codon and the anticodon bind. Fourth, the ribosome moves the mRNA strand along as each codon is read sequentially. Finally, as each amino acid is bound to the next by a polypeptide bond, its tRNA is released. The polypeptide or protein chain is released when the termination (stop) codon is read.
- 138) 1. The cytosol is a semitransparent fluid that is largely water, and contains dissolved nutrients and a variety of other solutes. Its function is to suspend the organelles and inclusions.  
 2. Organelles are the "little organs" (specialized cellular compartments) within the cytosol that carry out specific functions for the cell as a whole in order to maintain its life.  
 3. Inclusions are chemical substances dispersed in the cytoplasm that may or may not be present, depending on the specific cell type. Most are stored nutrients or cell products, which are nonfunctioning units.
- 139) 1. Messenger RNA (mRNA) carries the "message" containing instructions for protein synthesis from the DNA in the nucleus to the ribosomes in the cytoplasm.  
 2. Ribosomal RNA (rRNA) forms part of the "ribosomal" structure and helps coordinate the protein building process.  
 3. Transfer RNA (tRNA) transports an amino acid to the ribosomal site and recognizes the mRNA codons.
- 140) 1. The rough endoplasmic reticulum (ER):  
 a. is studded with ribosomes  
 b. makes proteins on its ribosomes  
 2. The smooth ER:  
 a. lacks ribosomes on its surface  
 b. functions in lipid metabolism, drug and pesticide detoxification
- 141) Isotonic solutions have the same solute and water concentrations as the cell. Isotonic solutions cause no visible changes in cells since there is not an area more highly concentrated. The use of isotonic intravenous solutions allows red blood cells to retain their normal size and disc-like shape.
- 142) 1. Skeletal tissue:  
 a. is attached to the skeleton  
 b. is under voluntary control  
 c. is multinucleate  
 d. possesses striations  
 e. is composed of long, cylindrical cells  
 2. Cardiac muscle:  
 a. is found only in the heart  
 b. is under involuntary control  
 c. is uninucleate  
 d. possesses striations  
 e. is composed of cells that are short and branching  
 f. possesses intercalated disks that contain gap junctions  
 3. Smooth muscle:  
 a. is found in walls of hollow organs

is uninucleate

- b.
    - c. lacks striations
    - d. possesses cells that are spindle shaped
- 143) 1. Lipid molecules (phospholipids) provide the medium in which protein molecules float, form the basic fabric of the membrane, and are relatively impermeable to most water-soluble molecules.
2. Cholesterol molecules have a stabilizing effect and help to keep the membrane fluid.
3. Protein molecules are responsible for the most specialized functions of the membrane. They act as enzymes, serve as receptors or binding sites for hormones and other chemical messengers, act as carriers that bind to substances and move them through the cell membrane, and form pores through which water and small molecules can move.
4. Carbohydrate molecules add an identification tag to mark protein molecules, and make the cell membrane a fuzzy, sticky, sugar-rich area.
5. Glycoprotein molecules determine blood type; act as receptors that certain bacteria, viruses, or their toxins can bind to; and play a role in cell-to-cell interactions.

Exam

Name \_\_\_\_\_

**MULTIPLE CHOICE. Choose the one alternative that best completes the statement or answers the question.**

- 1) Epidermal cells that are actively mitotic and replace superficial cells that are continually rubbed off are: 1) \_\_\_\_\_
  - A) stratum granulosum cells
  - B) stratum lucidum cells
  - C) stratum germinativum cells
  - D) stratum spinosum cells
  - E) stratum corneum cells
  
- 2) The uppermost layer of skin is: 2) \_\_\_\_\_
  - A) fed by a good supply of blood vessels
  - B) called the dermis
  - C) composed of dense connective tissue
  - D) full of keratin
  - E) called the hypodermis
  
- 3) The epidermis is composed of: 3) \_\_\_\_\_
  - A) simple columnar epithelium
  - B) areolar tissue
  - C) dense fibrous connective tissue
  - D) stratified squamous epithelium
  - E) adipose tissue
  
- 4) The "tanning" effect (darkening of the skin) that occurs when a person is exposed to the sun is due to: 4) \_\_\_\_\_
  - A) melanin
  - B) keratin
  - C) oil
  - D) sweat
  - E) Langerhans cells
  
- 5) Nails are composed of: 5) \_\_\_\_\_
  - A) keratin
  - B) carotene
  - C) hemoglobin
  - D) melanin
  - E) sebum
  
- 6) The categories of epithelial tissue membranes are: 6) \_\_\_\_\_
  - A) synovial, cutaneous, and serous membranes
  - B) synovial, mucous, and cutaneous membranes
  - C) mucous, cutaneous, and serous membranes
  - D) synovial, mucous, and serous membranes
  - E) synovial, cutaneous, and mucous membranes
  
- 7) Inflammation of the hair follicles and sebaceous glands is called: 7) \_\_\_\_\_
  - A) impetigo
  - B) alopecia
  - C) contact dermatitis

- D) psoriasis
- E) boils

- 8) Synovial membranes are found in the: 8) \_\_\_\_\_
- A) joint cavities
  - B) lining of the stomach cavity
  - C) covering of the brain
  - D) covering of the heart
  - E) lining of the abdominal cavity wall
- 9) Which of the following is NOT a true statement about the papillary layer of the dermis: 9) \_\_\_\_\_
- A) it is the deepest layer of the skin
  - B) it is highly vascular
  - C) it contains nerve endings that respond to touch and temperature stimuli
  - D) it produces the pattern for fingerprints
  - E) it is located immediately beneath the epidermis
- 10) The secretion of sweat is stimulated: 10) \_\_\_\_\_
- A) by high temperatures
  - B) by hormones, especially male sex hormones
  - C) as a protective coating when one is swimming
  - D) when the air temperature drops
  - E) both by high temperatures and by hormones, especially male hormones
- 11) Melanocytes are found in the: 11) \_\_\_\_\_
- A) stratum spinosum
  - B) stratum basale
  - C) stratum granulosum
  - D) stratum lucidum
  - E) stratum corneum
- 12) Finger-like upward projections of the dermis into the epidermis are called: 12) \_\_\_\_\_
- A) hair bulbs
  - B) dermal papillae
  - C) Pacinian corpuscles
  - D) hair follicles
  - E) Meissner's corpuscles
- 13) A physician estimates the volume of fluid lost in a severely burned patient by: 13) \_\_\_\_\_
- A) measuring urinary output and fluid intake
  - B) using the "rule of nines"
  - C) performing enzyme studies
  - D) blood analysis
  - E) observing the tissues that are usually moist
- 14) The secretions of the eccrine glands are: 14) \_\_\_\_\_
- A) solely metabolic wastes
  - B) basic
  - C) 99% water, sodium chloride, and trace amounts of wastes, lactic acid, and vitamin C
  - D) fatty substances, proteins, antibodies, and trace amounts of minerals and vitamins
  - E) primarily uric acid

- 15) The layer of the epidermis in which cells first die because of their inability to get nutrients and oxygen is the: 15) \_\_\_\_\_
- A) stratum basale
  - B) stratum corneum
  - C) stratum spinosum
  - D) stratum granulosum
  - E) stratum lucidum
- 16) Acne and seborrhea are caused by problems with: 16) \_\_\_\_\_
- A) nail beds
  - B) sebaceous glands
  - C) hair follicles
  - D) sudoriferous glands
  - E) eccrine glands
- 17) What is the first threat to life from a massive third-degree burn: 17) \_\_\_\_\_
- A) blood loss
  - B) infection
  - C) dehydration
  - D) loss of immune function
  - E) unbearable pain
- 18) In order to warm the body up when cold: 18) \_\_\_\_\_
- A) sudoriferous glands release sweat
  - B) melanin is produced
  - C) vitamin D is synthesized
  - D) the arrector pili muscles contract to stand hairs upright
  - E) sebaceous glands release oil
- 19) Which of the following homeostatic imbalances is caused by skin exposure to chemicals: 19) \_\_\_\_\_
- A) impetigo
  - B) athlete's foot
  - C) cyanosis
  - D) contact dermatitis
  - E) cold sores
- 20) The only dry membrane is the: 20) \_\_\_\_\_
- A) synovial membrane
  - B) mucous membrane
  - C) serous membrane
  - D) cutaneous membrane
  - E) basement membrane
- 21) Sweat glands associated with hair are: 21) \_\_\_\_\_
- A) sudoriferous glands
  - B) eccrine glands
  - C) sudoriferous glands and eccrine glands
  - D) sebaceous glands and eccrine glands
  - E) sebaceous glands
- 22) Which of the following relationships is incorrect: 22) \_\_\_\_\_
- A) visceral peritoneum - covers the outer surface of the small intestine

- B) parietal peritoneum – lines the wall of the abdominal cavity
- C) parietal pleura – lines the wall of thoracic cavity
- D) visceral pleura – lines the surface of the lungs
- E) parietal pericardium – covers the outer surface of the heart

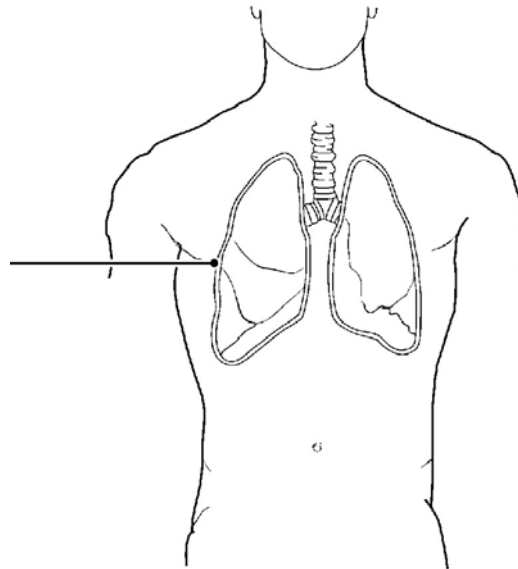

Figure 4.2

- 23) The membrane shown in Figure 4.2 is: 23) \_\_\_\_\_
- A) synovial membrane
  - B) cutaneous membrane
  - C) pleura, a serous membrane
  - D) pericardium, a serous membrane
  - E) mucous membrane
- 24) The hypodermis consists of: 24) \_\_\_\_\_
- A) adipose tissue
  - B) loose connective tissue
  - C) dense fibrous connective tissue
  - D) stratified squamous epithelium
  - E) simple columnar epithelium
- 25) Although you get wet while swimming, a tough protein within the skin prevents it from soaking up moisture like a sponge. This substance is: 25) \_\_\_\_\_
- A) carotene
  - B) mucus
  - C) keratin
  - D) melanin
  - E) serous fluid
- 26) Male pattern baldness has a genetic switch that turns on in response to: 26) \_\_\_\_\_
- A) weight
  - B) female hormones
  - C) age
  - D) size
  - E) male hormones

- 27) Which of the following is an indication of melanoma: 27) \_\_\_\_\_
- A) a symmetrical mole
  - B) a pigmented spot that contains areas of different colors
  - C) a pigmented spot that is black
  - D) a spot on the skin that is smaller than the size of a pencil eraser
  - E) a pigmented spot that has smooth borders
- 28) A splinter penetrates to the deepest layer of the epidermis on your foot. This layer is: 28) \_\_\_\_\_
- A) stratum granulosum
  - B) stratum spinosum
  - C) stratum corneum
  - D) stratum lucidum
  - E) stratum basale
- 29) A needle would pierce the epidermal layers of the forearm in which order: 29) \_\_\_\_\_
- 1. stratum basale
  - 2. stratum corneum
  - 3. stratum granulosum
  - 4. stratum lucidum
  - 5. stratum spinosum
- A) 1, 3, 5, 2, 4      B) 2, 4, 3, 5, 1      C) 2, 3, 5, 1      D) 1, 5, 3, 4, 2      E) 2, 3, 4, 1, 5
- 30) Nutrients reach the surface of the skin (epidermis) through the process of: 30) \_\_\_\_\_
- A) diffusion
  - B) evaporation
  - C) osmosis
  - D) absorption
  - E) filtration
- 31) Which of the following is a connective tissue membrane: 31) \_\_\_\_\_
- A) serous membrane
  - B) pleural membrane
  - C) cutaneous membrane
  - D) mucous membrane
  - E) synovial membrane
- 32) Sudoriferous glands are important for: 32) \_\_\_\_\_
- A) production of keratin
  - B) keeping skin and hair cells soft and flexible
  - C) body heat regulation
  - D) production of vitamin D
  - E) production of sweat
- 33) Which type of membrane contains fluid between the visceral and perietal layers: 33) \_\_\_\_\_
- A) serous
  - B) cutaneous
  - C) mucous
  - D) connective
  - E) synovial
- 34) Which of the following is a vital function of the skin: 34) \_\_\_\_\_
- A) the cells of the epidermis store glucose as glycogen for energy

- B) it converts modified epidermal cholesterol to vitamin D
- C) it aids in the transport of materials throughout the body
- D) it absorbs vitamin C so that the skin will not be subject to diseases
- E) it aids in desiccation

**SHORT ANSWER. Write the word or phrase that best completes each statement or answers the question.**

- 35) The gland that produces sweat is indicated by label \_\_\_\_\_ 35) \_\_\_\_\_
- 36) The layer of the serous membrane that covers an organ is known as the \_\_\_\_\_ layer. 36) \_\_\_\_\_

*Fill in the blank or provide a short answer:*

- 37) In a hair, the outermost single layer of cells that overlap one another like shingles is called the \_\_\_\_\_. 37) \_\_\_\_\_

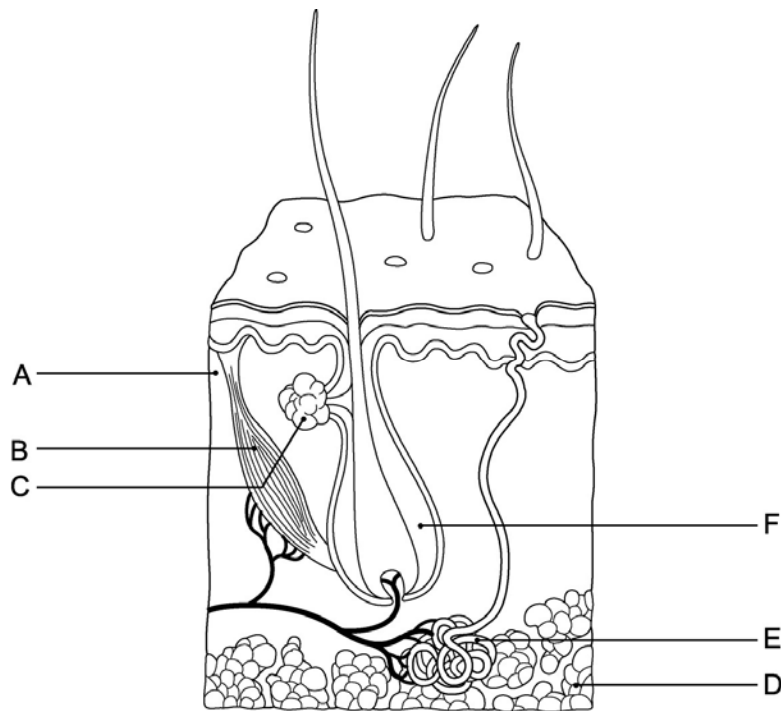

Figure 4.1

*Using Figure 4.1, identify the following:*

- 38) The hair follicle is indicated by letter \_\_\_\_\_. 38) \_\_\_\_\_

*Fill in the blank or provide a short answer:*

- 39) The type of burn that involves injury to the epidermis and the upper region of the dermis and is red, blistered, and painful is termed as a \_\_\_\_\_-degree burn. 39) \_\_\_\_\_
- 40) The two major categories of membranes are \_\_\_\_\_ and \_\_\_\_\_. 40) \_\_\_\_\_

*Fill in the blank or provide a short answer:*

- 41) The white, cheesy-looking substance that is produced by the sebaceous glands and protects a baby's skin while it is floating in its water-filled sac inside the mother is called \_\_\_\_\_. 41) \_\_\_\_\_
- 42) The gland that produces a mixture of oily substances and fragmented cells is indicated by label \_\_\_\_\_ 42) \_\_\_\_\_



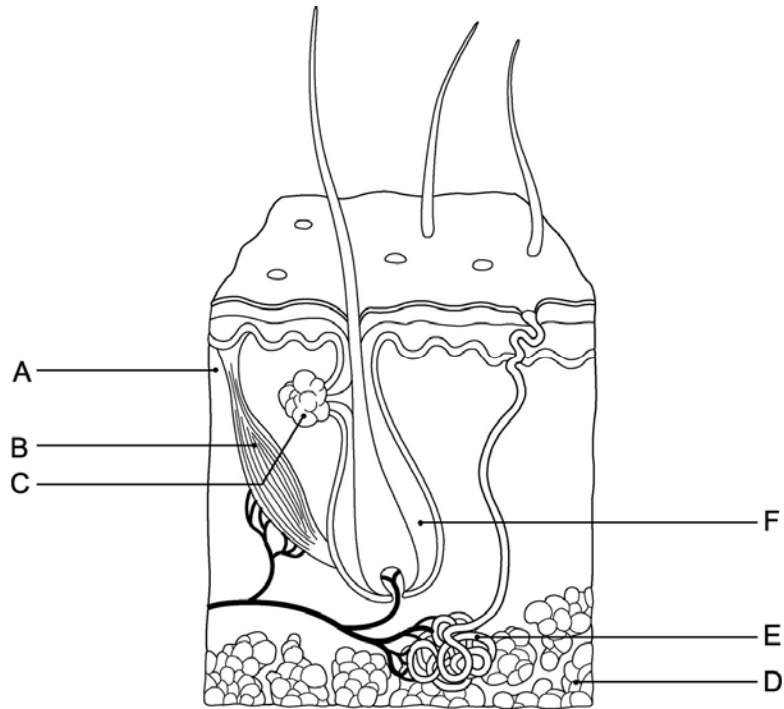

Figure 4.1

Using Figure 4.1, identify the following:

43) The region that contains adipose tissue is indicated by letter \_\_\_\_\_. 43) \_\_\_\_\_

44) Epithelial membranes contain two types of tissue, \_\_\_\_\_ and \_\_\_\_\_ tissue. 44) \_\_\_\_\_

Fill in the blank or provide a short answer:

45) The white crescent area located over the nail matrix is called the \_\_\_\_\_. 45) \_\_\_\_\_

46) The skin that covers the palms of the hands and the soles of the feet has an extra layer of epidermis called the stratum \_\_\_\_\_. 46) \_\_\_\_\_

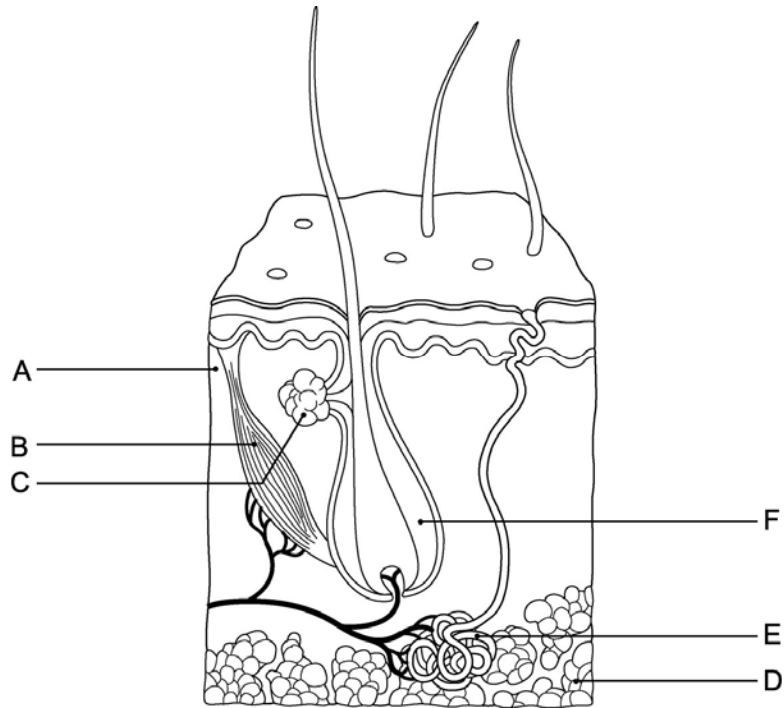

Figure 4.1

Using Figure 4.1, identify the following:

47) The structure that is responsible for whorled ridges on the epidermal surfaces is indicated by letter \_\_\_\_\_.

Fill in the blank or provide a short answer:

48) The deepest layer of the dermis is called the \_\_\_\_\_ layer.

49) The part of a hair that projects from the surface of the scalp or skin is called the \_\_\_\_\_.

50) The part of the hair enclosed in the follicle is known as the \_\_\_\_\_.

51) The type of connective tissue membrane found in joints is the \_\_\_\_\_.

Fill in the blank or provide a short answer:

52) The dermis is composed of the reticular and \_\_\_\_\_ layers.

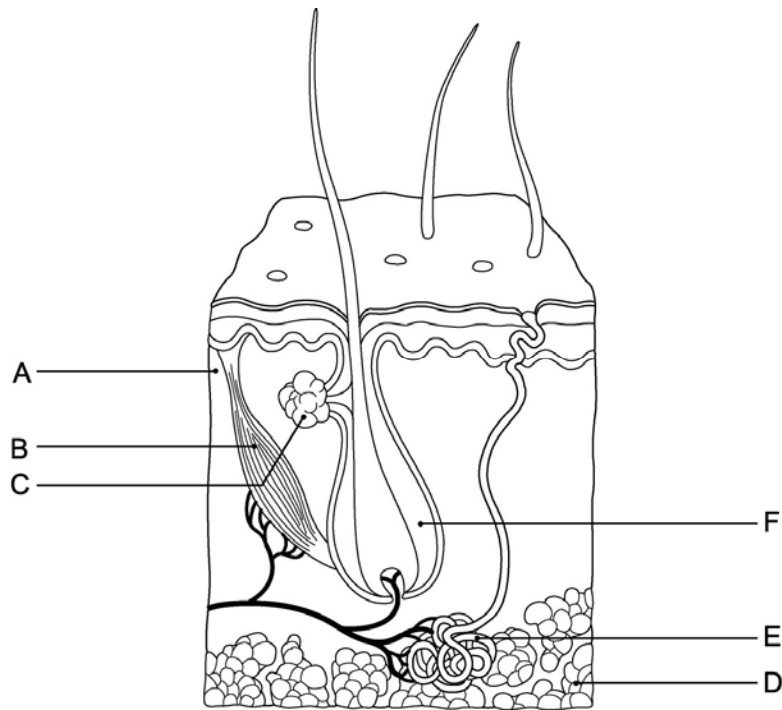

Figure 4.1

Using Figure 4.1, identify the following:

53) The structure that pulls the hair follicle into an upright position is indicated by letter \_\_\_\_\_.

Fill in the blank or provide a short answer:

54) The sebaceous glands produce \_\_\_\_\_.

55) "Goosebumps" are caused by contractions of the \_\_\_\_\_ muscles.

**TRUE/FALSE. Write 'T' if the statement is true and 'F' if the statement is false.**

56) Eccrine and apocrine glands are the two types of sebaceous glands. 56) \_\_\_\_\_

57) Joe just burned his hand on a hot pot. A blister forms and the burn is painful; Joe's burn would best be described as a third-degree burn. 57) \_\_\_\_\_

58) In first-degree burns, only the epidermis is damaged. 58) \_\_\_\_\_

59) The epidermis is made up of stratified squamous epithelium. 59) \_\_\_\_\_

60) The reason that the nail bed appears pink is the presence of a large number of melanocytes in the underlying dermis. 60) \_\_\_\_\_

61) Hair is produced by the hair bulb and is composed primarily of dead keratinized cells. 61) \_\_\_\_\_

62) The major portion of the skin is comprised of the dermis. 62) \_\_\_\_\_

63) The downy type of hair covering a newborn is called vernix caseosa. 63) \_\_\_\_\_

64) Melanin is found in the uppermost layer of skin and helps prevent water loss. 64) \_\_\_\_\_

- 65) The ABCD rule is used for classifying burns. 65) \_\_\_\_\_
- 66) Squamous cell carcinoma arises from cells of the stratum spinosum. 66) \_\_\_\_\_
- 67) The outermost layer of the epidermis is the stratum basale. 67) \_\_\_\_\_
- 68) A serous membrane is composed of a layer of simple squamous epithelium resting on a thin layer of areolar connective tissue. 68) \_\_\_\_\_
- 69) The nail is actually a modification of the skin and corresponds to the hooves of animals. 69) \_\_\_\_\_
- 70) Skin is also known as a synovial membrane. 70) \_\_\_\_\_
- 71) When an individual is exposed to extremely low air temperatures, the capillaries of the skin will dilate so that blood will flush into skin capillary beds and heat will be dissipated. 71) \_\_\_\_\_
- 72) The thickened, proximal area of the nail is called the nail matrix, and it is responsible for nail growth. 72) \_\_\_\_\_
- 73) Membranes that line body cavities that have openings to the exterior of the body are called mucous membranes. 73) \_\_\_\_\_
- 74) The pinkish hue of healthy individuals with fair skin is the result of the crimson color of oxygenated hemoglobin circulating in the dermal capillaries and reflecting through the dermis. 74) \_\_\_\_\_
- 75) The serous membrane that covers the external surface of both lungs is called the visceral pleura. 75) \_\_\_\_\_

**MATCHING. Choose the item in column 2 that best matches each item in column 1.**

*Match the following:*

- 76) Type of membrane that lines open body cavities                      A) mucous membrane                      76) \_\_\_\_\_

*Match the following:*

- 77) Apocrine gland                      A) sudoriferous glands largely confined to the axillary region                      77) \_\_\_\_\_

*Match the following:*

- 78) Acne                      A) infection of the sebaceous glands accompanied by skin pimples                      78) \_\_\_\_\_

*Match the following:*

- 79) Type of membrane adapted for absorption or secretion                      A) mucous membrane                      79) \_\_\_\_\_

- 80) Only example of a connective tissue membrane                      A) synovial membrane                      80) \_\_\_\_\_

*Match the following:*

- 81) Hair root                      A) part of the hair projecting from the skin surface

81) \_\_\_\_\_

B) part of the hair enclosed in the follicle

*Match the following:*

82) Impetigo

A) staphylococcus bacterial infection causing water-filled lesions around the mouth and nose

82) \_\_\_\_\_

*Match the following:*

83) Peritoneum, pericardium, and pleura are examples of this type of membrane

A) serous membrane

83) \_\_\_\_\_

B) synovial membrane

84) Type of membrane that has no epithelial cells at all

84) \_\_\_\_\_

*Match the following:*

85) Dermal sheath

A) divides to form hair cells

85) \_\_\_\_\_

86) Matrix

B) outermost covering of the hair follicle

86) \_\_\_\_\_

*Match the following:*

87) Seborrhea

A) overactivity of sebaceous glands that results in dandruff

87) \_\_\_\_\_

88) Athlete's foot

B) fungus infection between toes

88) \_\_\_\_\_

89) Psoriasis

C) overproduction of skin cells causing dry, silvery scales

89) \_\_\_\_\_

*Match the following:*

90) Type of membrane that contains a visceral and a parietal layer

A) serous membrane

90) \_\_\_\_\_

*Match the following:*

91) Cold sores

A) fluid-filled blisters caused by herpes simplex virus

91) \_\_\_\_\_

*Match the following:*

92) Type of membrane that is dry

A) cutaneous membrane

92) \_\_\_\_\_

*Match the following:*

93) Eccrine gland

A) sudoriferous glands found all over the body

93) \_\_\_\_\_

Match the following:

- |                          |  |           |
|--------------------------|--|-----------|
| 94) Decubitus ulcers     | A) malignancy of the lowest epidermal layer  | 94) _____ |
| 95) Alopecia             | B) partial-thickness burn                    | 95) _____ |
| 96) Third-degree burns   | C) cancer of skin pigment cells              | 96) _____ |
| 97) Basal cell carcinoma | D) hair thinning and some degree of baldness | 97) _____ |
| 98) Malignant melanoma   | E) bedsores                                  | 98) _____ |
|                          | F) full-thickness burn                       |           |

Match the following:

- |                     |                              |            |
|---------------------|------------------------------|------------|
| 99) Papillary layer | A) upper layer of the dermis | 99) _____  |
| 100) Medulla        | B) central core of each hair | 100) _____ |
|                     | C) lower layer of the dermis |            |

**ESSAY. Write your answer in the space provided or on a separate sheet of paper.**

- 101) Identify four changes that occur to the skin and subcutaneous connective tissue as a result of aging, and state how these changes can be delayed.
- 102) Explain how the skin helps regulate body temperature.
- 103) Define and explain the function of the arrector pili.
- 104) Thirteen-year-old John has been diagnosed with acne. Explain to him what causes acne.
- 105) Explain how the skin functions to protect deeper tissues.
- 106) Explain the ABCD rule.
- 107) List and describe the three types of epithelial membranes.
- 108) Distinguish between the appearances of partial-thickness and full-thickness burns.

- 1) C
- 2) D
- 3) D
- 4) A
- 5) A
- 6) C
- 7) E
- 8) A
- 9) A
- 10) E
- 11) B
- 12) B
- 13) B
- 14) C
- 15) E
- 16) B
- 17) C
- 18) D
- 19) D
- 20) D
- 21) A
- 22) E
- 23) C
- 24) A
- 25) C
- 26) C
- 27) B
- 28) E
- 29) C
- 30) A
- 31) E
- 32) C
- 33) A
- 34) B
- 35) E
- 36) visceral
- 37) cuticle
- 38) F
- 39) second
- 40) epithelial membranes; connective membranes
- 41) vernix caseosa
- 42) C
- 43) D
- 44) epithelial; connective
- 45) lunula
- 46) lucidum
- 47) A
- 48) reticular
- 49) shaft
- 50) root
- 51) synovial membrane

- 52) papillary
- 53) B
- 54) oil (sebum)
- 55) arrector pili
- 56) FALSE
- 57) FALSE
- 58) TRUE
- 59) TRUE
- 60) FALSE
- 61) TRUE
- 62) TRUE
- 63) FALSE
- 64) FALSE
- 65) FALSE
- 66) TRUE
- 67) FALSE
- 68) TRUE
- 69) TRUE
- 70) FALSE
- 71) FALSE
- 72) TRUE
- 73) TRUE
- 74) TRUE
- 75) TRUE
- 76) A
- 77) A
- 78) A
- 79) B
- 80) A
- 81) B
- 82) A
- 83) A
- 84) B
- 85) B
- 86) A
- 87) A
- 88) B
- 89) C
- 90) A
- 91) A
- 92) A
- 93) A
- 94) E
- 95) D
- 96) F
- 97) A
- 98) C
- 99) A
- 100) B
- 101)
  1. The amount of subcutaneous tissue below the skin decreases, leading to an intolerance to cold in the elderly.
  2. Because of decreased oil production and declining numbers of collagen fibers, the skin becomes drier and may become itchy and bothersome.



3. skin makes it more susceptible to bruising and other types of injuries.

Thin 4. A decrease in elasticity of the skin, along with the loss of subcutaneous fat, allows bags to form under the eyes and causes jowls to sag.

of To delay these changes, the skin should be kept clean and shielded from the sun, and a healthy diet with plenty of the fluids should be maintained.

102) The nervous system is responsible for controlling all temperature-regulating functions of the skin. When the temperature in the external environment is high, heat loss occurs as the nervous system activates sweat glands. Perspiration is produced, which evaporates from the skin surface, causing heat to be dissipated. At the same time, the nervous system causes blood to be flushed into skin capillary beds so that heat radiates from the body surface. In contrast, when the temperature in the external environment is low, the nervous system prevents blood from entering the skin capillary system and radiation to the body exterior is prevented so that perspiration does not occur. At the same time, blood is prevented from entering deeper tissues and the core temperature of the body is maintained.

103) The arrector pili are small bands of smooth muscle cells that connect each side of a hair follicle to the dermal tissue. They are activated by cold or fright and, when contracted, pull the hair follicle into an upright position, dimpling the skin surface with "goose bumps."

104) Acne is an active infection of the sebaceous glands accompanied by pimples on the skin. Sebaceous glands release sebum, or oil, onto the skin's surface.

105) Skin contains:

1. keratin which toughens cells and serves as a barrier to mechanical damage and chemical damage; keratin also serves to waterproof the skin to prevent desiccation
2. acidic oily secretions that prevent bacterial damage
3. melanin to protect from UV damage
4. receptors to detect heat, cold, and pain; serves as a protection against thermal damage

106) The ABCD rule describes the appearance of the most serious form of skin cancer, melanoma. The "A" is for asymmetry. In melanoma, the two sides of the pigmented spot or mole do not match. The "B" is for border irregularity. In melanoma, the borders of the lesion are not smooth but exhibit indentations. The "C" is for color. In melanoma, the pigmented spot contains areas of different colors (blacks, browns, tans, and sometimes blues and reds). The "D" is for diameter. In melanoma, the spot is larger than 6 mm in diameter (the size of a pencil eraser).

107) 1. Cutaneous membrane is:

- a. skin
- b. dry
- c. composed of keratinizing stratified squamous epithelium and the underlying connective tissue is often dense and fibrous.

2. Mucous membrane:

- a. is moist
- b. is found lining all body cavities that open to the exterior
- c. often contains stratified squamous epithelium or simple columnar epithelium

3. Serous membrane:

- a. is composed of two layers (visceral layer covers the organ in the cavity while the parietal layer lines a specific portion of the wall of the ventral body cavity)
- b. covers organs in body cavities that are closed to the exterior
- c. is constructed of simple squamous epithelium overlying a thin layer of areolar connective tissue

108) *Partial thickness burns* are burns that don't completely damage both layers of skin, and include first- and second-degree burns. In first-degree burns only the epidermis is damaged, with redness and swelling and some pain. These burns typically heal in two to three days without special attention. Second-degree burns involve injury to the epidermis and upper region of the dermis. They are characterized by redness, blisters, and pain. Ordinarily, no permanent scars result if care is taken to prevent infection.

*Full-thickness burns* destroy the entire thickness of skin and are also termed third-degree burns. In third-degree burns, the burned area appears blanched (gray-white) or blackened. The burned area is not painful since nerve endings in the area are destroyed. Regeneration is not possible, therefore skin grafting must be done to cover underlying exposed tissues.

Exam

Name \_\_\_\_\_

**MULTIPLE CHOICE. Choose the one alternative that best completes the statement or answers the question.**

- 1) The canal that runs through the core of each osteon contains: 1) \_\_\_\_\_  
A) red marrow  
B) cartilage and lamellae  
C) yellow marrow and Sharpey's fibers  
D) osteoclasts and osteoblasts  
E) blood vessels and nerve fibers
- 2) Which of these bones is NOT associated with the foot: 2) \_\_\_\_\_  
A) tarsals  
B) calcaneus  
C) metatarsals  
D) talus  
E) metacarpals
- 3) Articulations permitting only slight degrees of movement are \_\_\_\_\_, whereas articulations permitting no movement are called \_\_\_\_\_. 3) \_\_\_\_\_  
A) amphiarthroses; synarthroses  
B) amphiarthroses; diarthroses  
C) diarthroses; amphiarthroses  
D) diarthroses; synarthroses  
E) synarthroses; amphiarthroses
- 4) There are \_\_\_\_\_ vertebrae in the neck region. 4) \_\_\_\_\_  
A) seven cervical  
B) five lumbar  
C) twelve thoracic  
D) seven lumbar  
E) five thoracic
- 5) What type of cell does parathyroid hormone (PTH) activate: 5) \_\_\_\_\_  
A) periosteum  
B) lacunae  
C) osteoblast  
D) osteocyte  
E) osteoclast

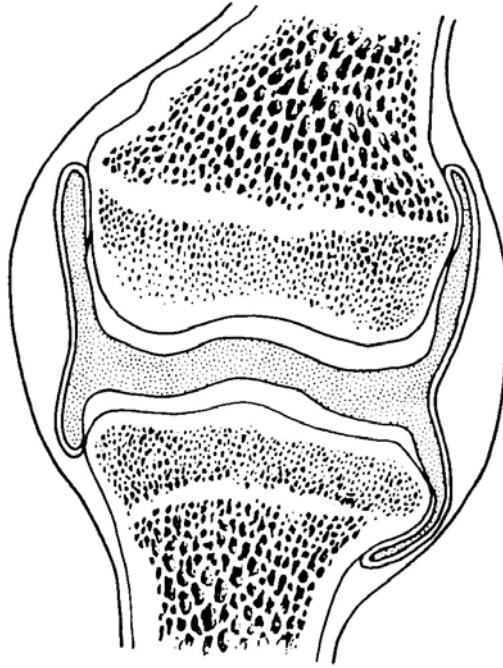

Figure 5.4

- 6) The type of joint shown in Figure 5.4 is: 6) \_\_\_\_\_
- A) a suture
  - B) a cartilaginous joint
  - C) a fibrous joint
  - D) an amphiarthrotic joint
  - E) a synovial joint
- 7) The atlas is the: 7) \_\_\_\_\_
- A) last lumbar vertebra
  - B) part of the sacrum
  - C) first thoracic vertebra
  - D) second cervical vertebra
  - E) first cervical vertebra
- 8) Which of the following is correct of the female pelvis when comparing it with the male pelvis: 8) \_\_\_\_\_
- A) the distance between the female ischial spines is greater
  - B) the angle of the female pubic arch is smaller
  - C) the female pelvis as a whole is deeper, and the bones are heavier and thicker
  - D) the female iliac bones are less flared
  - E) the distance between the female ischial tuberosities is less
- 9) All of the following facial bones are paired except one. Which of the following is the unpaired facial bone: 9) \_\_\_\_\_
- A) maxillae
  - B) lacrimal
  - C) zygomatic
  - D) palatine
  - E) vomer
- 10) The sella turcica is part of the \_\_\_\_\_ bone. 10) \_\_\_\_\_
- A) ethmoid
  - B) parietal
  - C) frontal
  - D) sphenoid
  - E) temporal
- 11) In adults, the function of the yellow marrow is to: 11) \_\_\_\_\_
- A) decrease friction at joint surfaces
  - B) store adipose tissue

- C) form blood cells
  - D) store calcium and phosphorus
  - E) cause lengthwise growth in long bones
- 12) The hyoid bone is unique because: 12) \_\_\_\_\_
- A) it has no specific function
  - B) it largely consists of cartilage
  - C) it has an unusual shape
  - D) it is covered with mucosa
  - E) it is the only bone of the body that does not directly articulate with any other bone
- 13) Which of the following groups of bones in the human body, categorized according to shape, is correct: 13) \_\_\_\_\_
- A) coxal bones - irregular bones
  - B) cranium - sesamoid bones
  - C) skull bones - flat bones
  - D) arm and leg bones - short bones
  - E) wrist and ankle bones - long bones
- 14) A structure found on the femur is the: 14) \_\_\_\_\_
- A) anterior crest
  - B) intercondylar fossa
  - C) trochlea
  - D) lateral malleolus
  - E) medial malleolus
- 15) What kind of tissue is the forerunner of long bones in the embryo: 15) \_\_\_\_\_
- A) dense fibrous connective tissue
  - B) hyaline cartilage
  - C) fibrocartilage
  - D) elastic connective tissue
  - E) loose fibrous connective tissue
- 16) The sternum is the result of fusion of three bones called the: 16) \_\_\_\_\_
- A) ischium, ilium, coccyx
  - B) true ribs, manubrium, xiphoid process
  - C) manubrium, body, xiphoid process
  - D) jugular notch, sternal angle, xiphisternal joint
  - E) pubis, ischium, ilium
- 17) The presence of an epiphyseal plate indicates that: 17) \_\_\_\_\_
- A) bone is dead
  - B) bone diameter is decreasing
  - C) bone diameter is increasing
  - D) bone length is increasing
  - E) bone length is no longer increasing
- 18) The suture found between the parietal and temporal bone is the: 18) \_\_\_\_\_
- A) coronal suture
  - B) sagittal suture
  - C) both the squamous suture and the sagittal suture
  - D) lambdoid suture

E) squamous suture

19) The bone cells within lacunae receive nourishment from blood vessels through passageways called: 19) \_\_\_\_\_

- A) perforating canals
- B) medullary cavities
- C) lamellae
- D) Haversian canals
- E) canaliculi

20) Transverse foramina are found in the: 20) \_\_\_\_\_

- A) lumbar vertebrae
- B) thoracic vertebrae
- C) cervical vertebrae
- D) sacrum
- E) coccyx

21) A shallow, basin-like depression in a bone often serving as an articular surface is a: 21) \_\_\_\_\_

- A) meatus
- B) foramen
- C) fossa
- D) sinus
- E) groove

22) Which is the correct order of ribs, from superior to inferior: 22) \_\_\_\_\_

- A) floating ribs, true ribs, false ribs
- B) floating ribs, false ribs, true ribs
- C) true ribs, false ribs, floating ribs
- D) false ribs, floating ribs, true ribs
- E) true ribs, floating ribs, false ribs

23) The factor(s) that determine *where* bone matrix is to be remodeled is (are): 23) \_\_\_\_\_

- A) sex hormones
- B) stresses of gravity and muscle pull on the skeleton
- C) calcium level of the blood
- D) growth hormone
- E) parathyroid hormone (PTH)

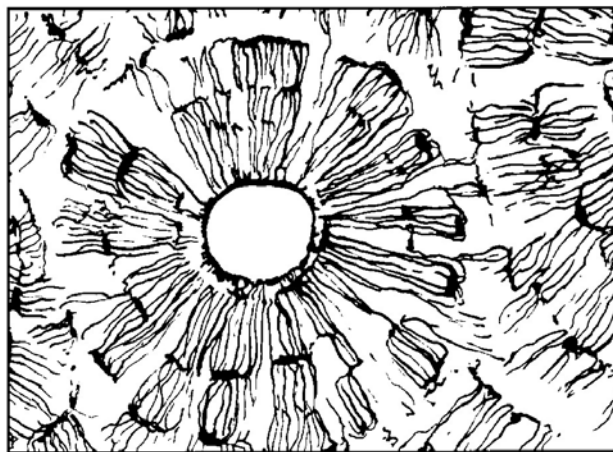

Figure 5.3

24) The type of tissue shown in Figure 5.3 is found mostly in: 24) \_\_\_\_\_

- A) articular cartilage
- B) short bones

- C) yellow marrow
- D) the epiphysis
- E) the diaphysis

- 25) Four of the five answers listed below are parts of the same anatomical area. Select the exception. 25) \_\_\_\_\_  
A) radius            B) clavicle            C) fibula            D) humerus            E) scapula
- 26) A compound fracture can be described as when: 26) \_\_\_\_\_  
A) the bone is broken into many fragments  
B) the bone is crushed  
C) the broken bone ends are forced into each other  
D) the broken bone is exposed to the outside  
E) adjacent bones fracture simultaneously
- 27) The axial skeleton contains: 27) \_\_\_\_\_  
1. skull  
2. arms and legs  
3. ribs and sternum  
4. vertebrae  
5. pelvic girdles  
A) 1, 2, 3, 5            B) 1, 3, 4            C) 1, 3, 4, 5            D) 2, 5            E) 2, 3, 4, 5
- 28) Which of these bones is NOT a long bone found in the leg: 28) \_\_\_\_\_  
A) femur  
B) fibula  
C) metatarsals  
D) tibia  
E) patella
- 29) Osteons are characteristic of \_\_\_\_\_. 29) \_\_\_\_\_  
A) compact bone  
B) articular cartilage  
C) yellow marrow  
D) spongy bone  
E) Sharpey's fibers
- 30) Which of the following is an example of a bone that forms from fibrous membranes: 30) \_\_\_\_\_  
A) the parietal bone  
B) the femur  
C) the humerus  
D) the radius  
E) the tibia
- 31) Fingers and toes are referred to as: 31) \_\_\_\_\_  
A) tarsals  
B) carpals  
C) metatarsals  
D) metacarpals  
E) phalanges
- 32) A round or oval opening through a bone is a: 32) \_\_\_\_\_  
A) fossa            B) fissure            C) facet            D) foramen            E) trochanter

- 33) A fracture that is common in children, whose bones have relatively more collagen in their matrix and are more flexible than those of adults, is a(n): 33) \_\_\_\_\_
- A) depressed fracture
  - B) spiral fracture
  - C) open fracture
  - D) impacted fracture
  - E) greenstick fracture
- 34) The small cavities in bone tissue where osteocytes are found are called: 34) \_\_\_\_\_
- A) lacunae
  - B) lamellae
  - C) trabeculae
  - D) Volkmann's canals
  - E) Haversian canals
- 35) The greater trochanter is located on the: 35) \_\_\_\_\_
- A) femur                      B) humerus                      C) fibula                      D) tibia                      E) radius
- 36) The most important minerals stored in bones are: 36) \_\_\_\_\_
- A) calcium and iron
  - B) calcium and potassium
  - C) sodium and potassium
  - D) calcium and phosphorus
  - E) sodium and phosphorus
- 37) A bone fracture where the bone is broken into many fragments is a: 37) \_\_\_\_\_
- A) compound fracture
  - B) compression fracture
  - C) simple fracture
  - D) comminuted fracture
  - E) greenstick fracture
- 38) The middle nasal conchae are part of the: 38) \_\_\_\_\_
- A) sphenoid bone
  - B) vomer bone
  - C) nasal bone
  - D) ethmoid bone
  - E) maxillae
- 39) A fracture that is common in osteoporotic bones is a(n): 39) \_\_\_\_\_
- A) depressed fracture
  - B) spiral fracture
  - C) simple fracture
  - D) compression fracture
  - E) impacted fracture
- 40) Which of these are bone-forming cells: 40) \_\_\_\_\_
- A) osteocytes
  - B) osteoclasts
  - C) lamellae
  - D) canaliculi

E) osteoblasts

- 41) There are four stages in the healing of a bone fracture. Which of the following best illustrates the sequence of these stages: 41) \_\_\_\_\_
1. bony callus formation      3. fibrocartilage callus formation  
2. bone remodeling          4. hematoma formation
- A) 1, 3, 2, 4      B) 4, 3, 1, 2      C) 1, 2, 3, 4      D) 1, 3, 4, 2      E) 4, 3, 2, 1
- 42) Bone formation can be referred to as: 42) \_\_\_\_\_
- A) osteoarthritis  
B) gout  
C) osteoporosis  
D) ossification  
E) rickets
- 43) The periosteum is secured to the underlying bone by dense connective tissue fibers called: 43) \_\_\_\_\_
- A) endochondral bone  
B) Sharpey's fibers  
C) articular cartilage  
D) a bony matrix with hyaline cartilage  
E) Volkmann's canals
- 44) The tailbone is the: 44) \_\_\_\_\_
- A) pubis      B) sacrum      C) coccyx      D) patella      E) ischium
- 45) Which of the following bone categories is composed of two layers of compact bone sandwiching a layer of spongy bone between them: 45) \_\_\_\_\_
- A) flat bone  
B) irregular bone  
C) compact bone  
D) long bone  
E) sesamoid bone

**SHORT ANSWER. Write the word or phrase that best completes each statement or answers the question.**



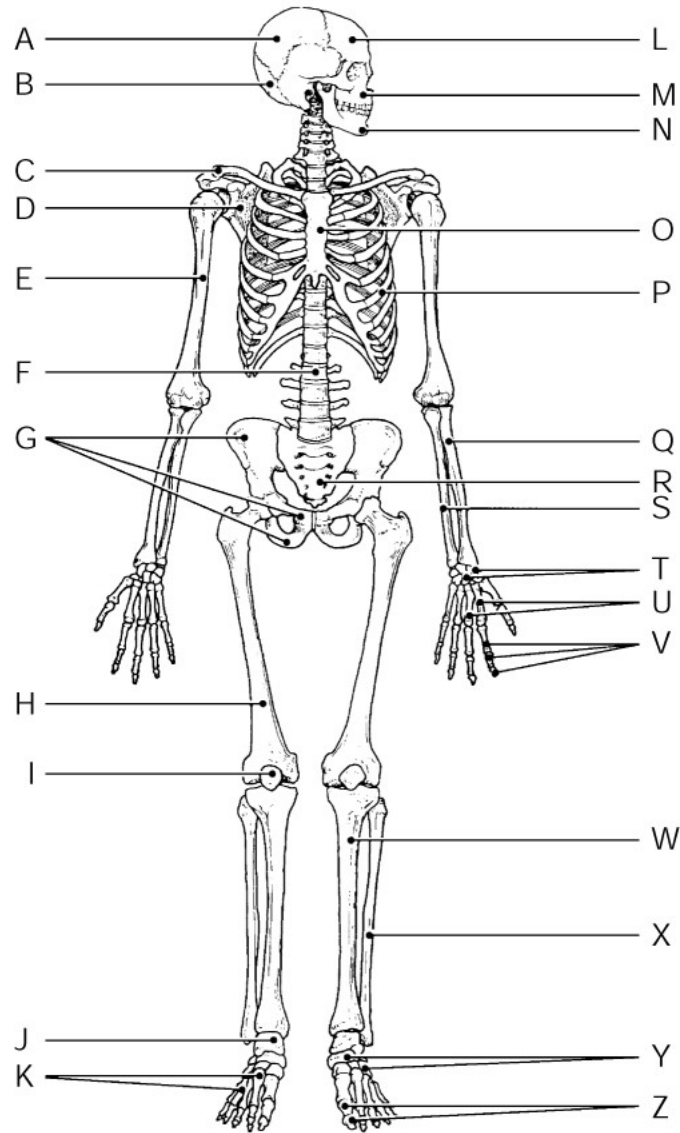

Figure 5.2

Using Figure 5.2, identify the following:

46) The femur is indicated by letter \_\_\_\_\_.

46) \_\_\_\_\_

47) The phalanges of the foot are indicated by letter \_\_\_\_\_.

47) \_\_\_\_\_

48) The sacrum is indicated by letter \_\_\_\_\_.

48) \_\_\_\_\_

Fill in the blank or provide a short answer:

49) The disease in which uric acid accumulates in the blood and may be deposited as needle-shaped crystals in the soft tissues of joints is called \_\_\_\_\_.

49) \_\_\_\_\_

50) The disease in children whose diets lack calcium or vitamin D, where the bones fail to calcify, is called \_\_\_\_\_.

50) \_\_\_\_\_

51) The head of the humerus fits into the \_\_\_\_\_ of the scapula.

51) \_\_\_\_\_

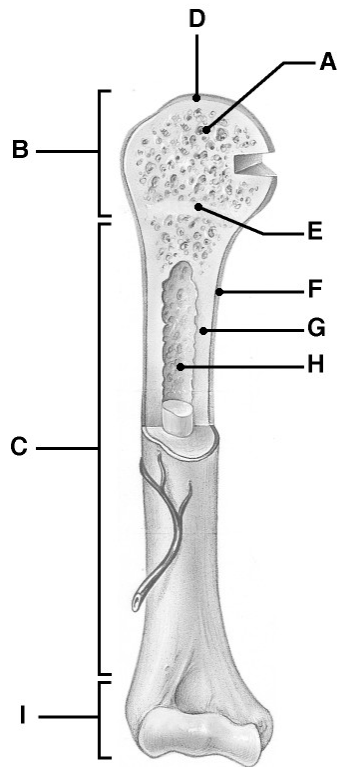

Figure 5.1

Using Figure 5.1, identify the following:

- 52) The area that contains glassy hyaline cartilage that provides a smooth slippery surface which decreases friction is indicated by letter \_\_\_\_\_ 52) \_\_\_\_\_

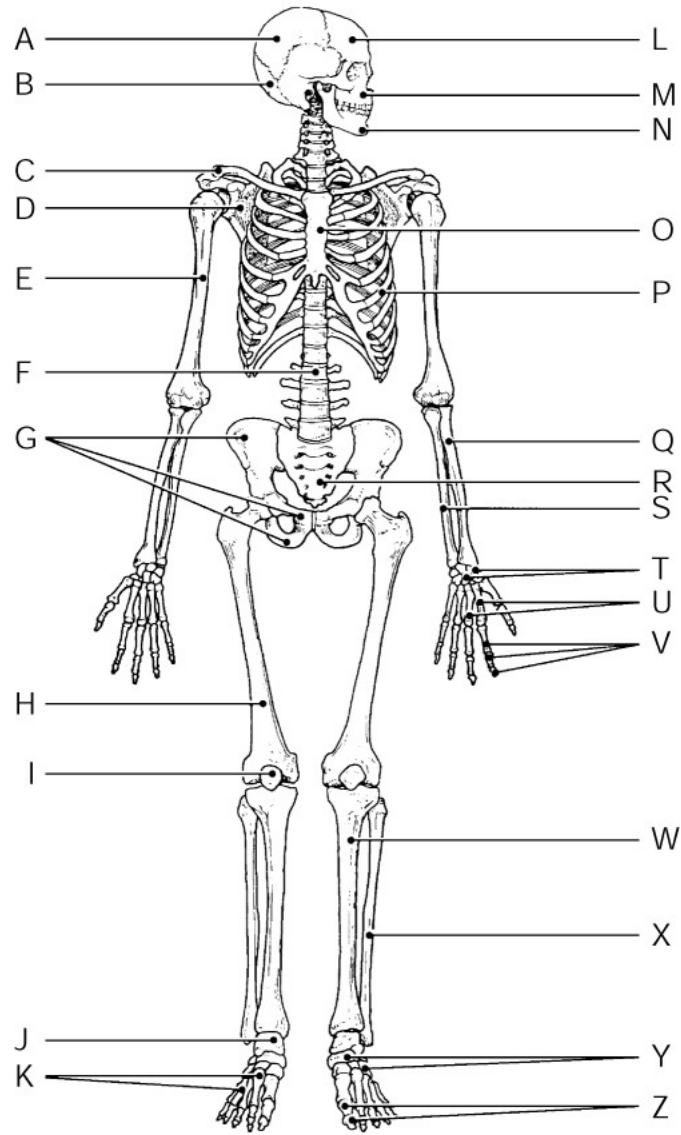

Figure 5.2

Using Figure 5.2, identify the following:

53) The mandible is indicated by letter \_\_\_\_\_.

53) \_\_\_\_\_

Fill in the blank or provide a short answer:

54) A round or oval hole through a bone, which contains blood vessels and/or nerves, is called a \_\_\_\_\_.

54) \_\_\_\_\_

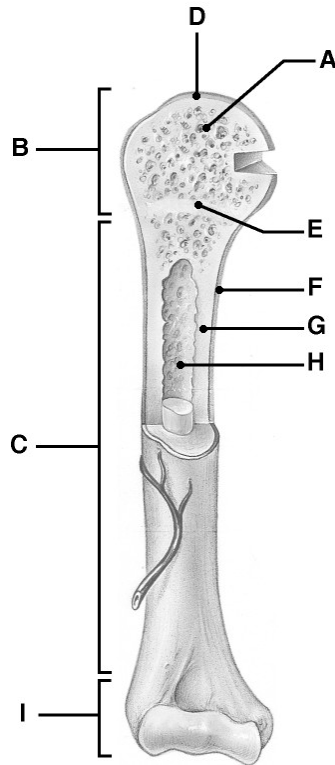

Figure 5.1

Using Figure 5.1, identify the following:

55) The distal epiphysis is indicated by letter \_\_\_\_\_.

55) \_\_\_\_\_

56) The diaphysis is indicated by letter \_\_\_\_\_.

56) \_\_\_\_\_

Fill in the blank or provide a short answer:

57) The heel bone is called the \_\_\_\_\_.

57) \_\_\_\_\_

58) A large rounded projection on a bone is called a \_\_\_\_\_.

58) \_\_\_\_\_

59) The elbow joint is an example of a \_\_\_\_\_ joint in which movement occurs in only one plane.

59) \_\_\_\_\_

60) A fracture where the bone breaks cleanly but does not penetrate the skin is termed a \_\_\_\_\_ fracture.

60) \_\_\_\_\_

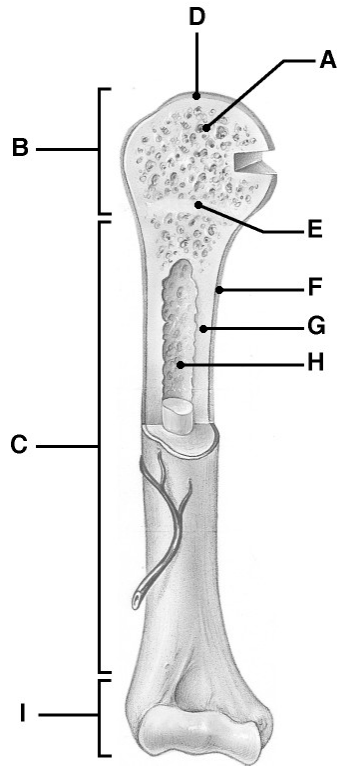

Figure 5.1

Using Figure 5.1, identify the following:

61) The area that causes the lengthwise growth of a long bone is indicated by letter \_\_\_\_\_.

61) \_\_\_\_\_

Fill in the blank or provide a short answer:

62) Cube-shaped bones that contain mostly spongy bone are called \_\_\_\_\_ bones.

62) \_\_\_\_\_

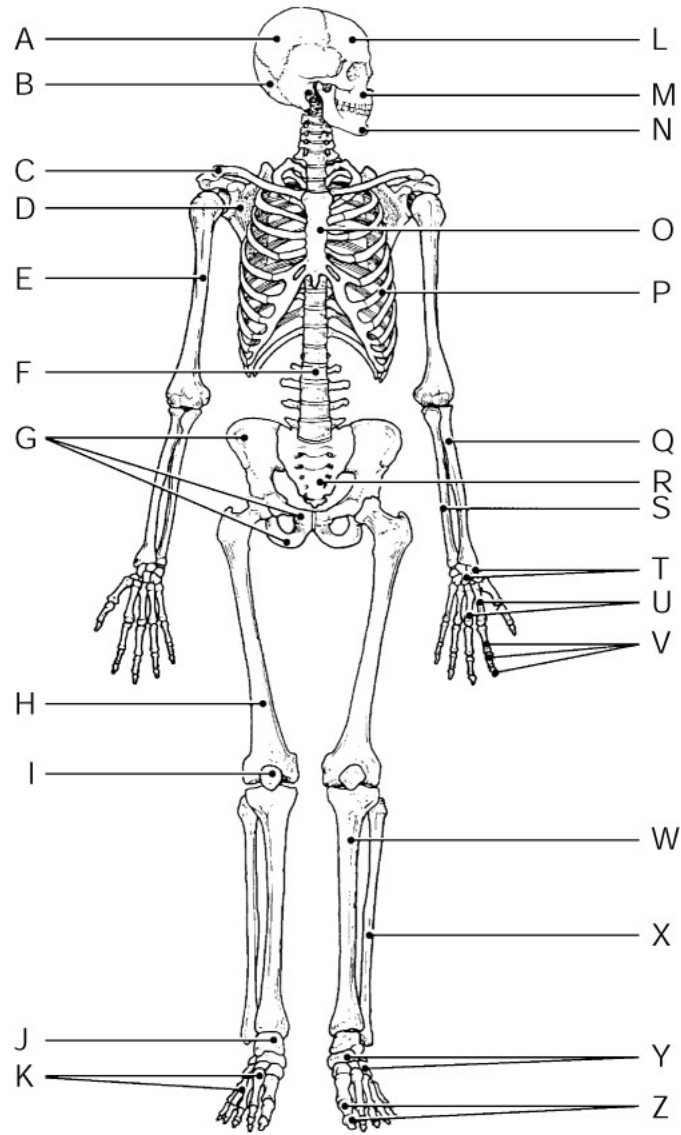

Figure 5.2

Using Figure 5.2, identify the following:

63) The sternum is indicated by letter \_\_\_\_\_.

63) \_\_\_\_\_

64) The radius bone is indicated by letter \_\_\_\_\_.

64) \_\_\_\_\_

Fill in the blank or provide a short answer:

65) The part of the ethmoid bone that contains holey areas with fibers that carry impulses from the olfactory receptors of the nose to the brain is the \_\_\_\_\_.

65) \_\_\_\_\_

66) \_\_\_\_\_ are giant cells that destroy bone.

66) \_\_\_\_\_

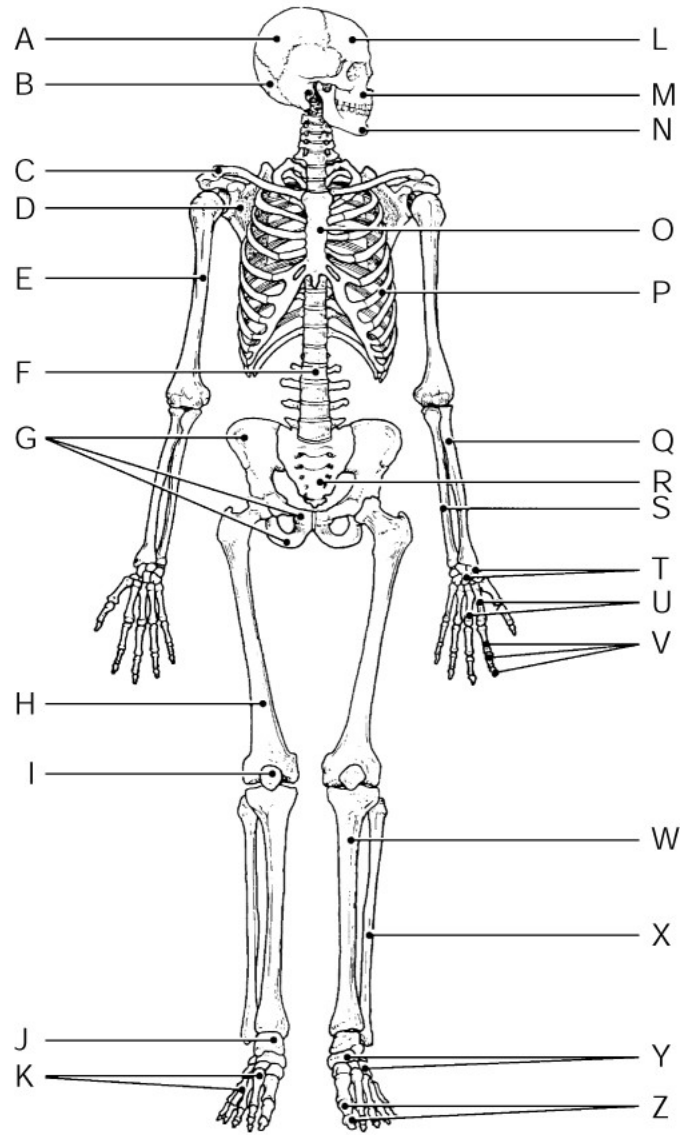

Figure 5.2

Using Figure 5.2, identify the following:

67) The scapula is indicated by letter \_\_\_\_\_.

67) \_\_\_\_\_

68) The frontal bone is indicated by letter \_\_\_\_\_.

68) \_\_\_\_\_

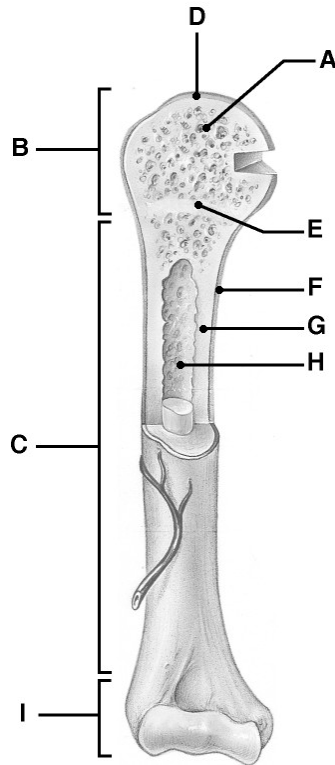

Figure 5.1

Using Figure 5.1, identify the following:

69) The area that serves as a storage area for fat in adults is indicated by letter \_\_\_\_\_. 69) \_\_\_\_\_

Fill in the blank or provide a short answer:

70) The only freely movable bone in the skull is the \_\_\_\_\_. 70) \_\_\_\_\_

71) List and discuss the structures of a long bone. 71) \_\_\_\_\_

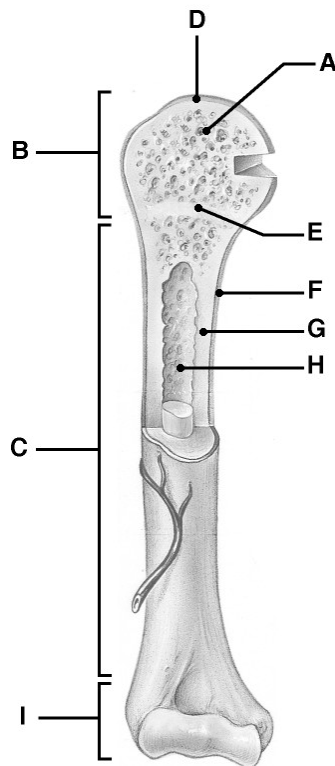



Figure 5.1

Using Figure 5.1, identify the following:

72) Spongy bone is indicated by letter \_\_\_\_\_.

72) \_\_\_\_\_

Fill in the blank or provide a short answer:

73) The external acoustic (auditory) meatus is found on the \_\_\_\_\_ bone.

73) \_\_\_\_\_

74) Blood cell formation is called \_\_\_\_\_.

74) \_\_\_\_\_

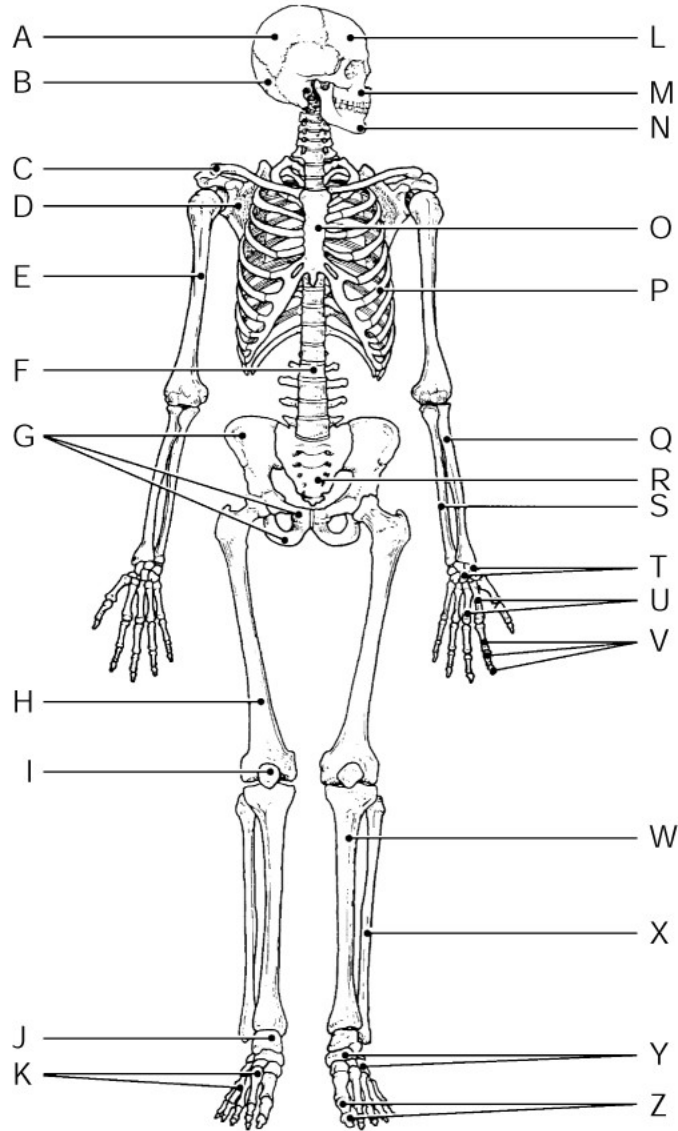

Figure 5.2

Using Figure 5.2, identify the following:

75) The fibula is indicated by letter \_\_\_\_\_.

75) \_\_\_\_\_

Fill in the blank or provide a short answer:

76) An increase in bone diameter is called \_\_\_\_\_ growth.

76) \_\_\_\_\_

**TRUE/FALSE. Write 'T' if the statement is true and 'F' if the statement is false.**

77) Osteoblasts respond to the parathyroid hormone (PTH).

77) \_\_\_\_\_

- 78) Spinal curvatures that are present at birth are called primary curvatures (the cervical and lumbar curvatures) and those that develop later are secondary curvatures (the thoracic and sacral curvatures). 78) \_\_\_\_\_
- 79) In anatomical position, the lateral lower leg bone is the fibula. 79) \_\_\_\_\_
- 80) Most of the stress on the vertebral column occurs on the sturdiest vertebrae in the sacral region. 80) \_\_\_\_\_
- 81) The diaphysis of a long bone is composed of spongy bone. 81) \_\_\_\_\_
- 82) The heaviest, strongest bone in the body is the femur. 82) \_\_\_\_\_
- 83) Hematopoiesis refers to the formation of blood cells within the red marrow cavities of certain bones. 83) \_\_\_\_\_
- 84) The master gland of the body (pituitary gland) is housed in a saddlelike depression in the temporal bone called the *sella turcica*. 84) \_\_\_\_\_
- 85) There are seven cervical, twelve thoracic, and five lumbar vertebrae. 85) \_\_\_\_\_
- 86) Ribs numbered 11 and 12 are true ribs because they have no anterior attachments. 86) \_\_\_\_\_
- 87) The zygomatic bones form the cheekbones. 87) \_\_\_\_\_
- 88) The spinal cord passes through the body of each vertebra. 88) \_\_\_\_\_
- 89) Fontanelles allow for growth of the brain. 89) \_\_\_\_\_
- 90) All flat bones are formed from hyaline cartilage. 90) \_\_\_\_\_

**MATCHING. Choose the item in column 2 that best matches each item in column 1.**

*Match the following:*

- |                    |                          |           |
|--------------------|--------------------------|-----------|
| 91) Knuckle joints | A) ball-and-socket joint | 91) _____ |
| 92) Shoulder joint | B) condyloid joint       | 92) _____ |

*Match the following:*

- |  |               |           |
|--|---------------|-----------|
| 93) Fracture where bone fragments into many pieces | A) comminuted | 93) _____ |
|--|---------------|-----------|

*Match the following:*

- |   |                |           |
|---|----------------|-----------|
| 94) Cells that can dissolve the bony matrix | A) osteons     | 94) _____ |
|   | B) osteoclasts |           |

*Match the following:*

- |                |                   |           |
|----------------|-------------------|-----------|
| 95) Coxal bone | A) irregular bone | 95) _____ |
|----------------|-------------------|-----------|

*Match the following:*

96) Wrist joint	A) plane joint	96) _____
<i>Match the following:</i>		
97) Small channels that radiate through the matrix of bone	A) canaliculi	97) _____
	B) Sharpey's fibers	
<i>Match the following:</i>		
98) Sternum	A) flat bone	98) _____
<i>Match the following:</i>		
99) Type of fracture in which bone is crushed	A) compression	99) _____
<i>Match the following:</i>		
100) Patella	A) short bone	100) _____
101) Carpals	B) short and sesamoid bone	101) _____
<i>Match the following:</i>		
102) Type of fracture in which the broken bone portion is pressed inward	A) depressed	102) _____
<i>Match the following:</i>		
103) True ribs	A) flat bone	103) _____
<i>Match the following:</i>		
104) An incomplete fracture or cracking of the bone without actual separation of the parts (common in children)	A) greenstick	104) _____
<i>Match the following:</i>		
105) Femur	A) long bone	105) _____
<i>Match the following:</i>		
106) Elbow joint	A) hinge joint	106) _____
<i>Match the following:</i>		
107) Parietal bones	A) flat bone	107) _____
<i>Match the following:</i>		
108) Area where bone growth takes place	A) epiphyseal plate	108) _____
109) Cells that can build bony matrix	B) osteocytes	109) _____
	C) osteoblasts	

D) epiphyseal line

*Match the following:*

110) Atlas

A) irregular bone

110) \_\_\_\_\_

*Match the following:*

111) Layers of calcification that are found in bone

A) lacunae

111) \_\_\_\_\_

B) lamellae

*Match the following:*

112) Fracture in which broken bone ends are forced into each other

A) impacted

112) \_\_\_\_\_

*Match the following:*

113) Ulna

A) long bone

113) \_\_\_\_\_

*Match the following:*

114) Joint between atlas and axis

A) pivot joint

114) \_\_\_\_\_

B) saddle joint

*Match the following:*

115) Fibula

A) long bone

115) \_\_\_\_\_

**ESSAY. Write your answer in the space provided or on a separate sheet of paper.**

116) If 6-year-old Sarah fell and broke her femur, damaging the proximal epiphyseal plate, what might she expect as she grows older? What is an epiphyseal plate and why is it significant to this situation?

117) List some of the features of a female pelvis that make it different from a male pelvis.

118) Differentiate the roles of osteoclasts, osteoblasts, and osteocytes in bone.

119) Define fontanel and discuss its functions. Identify the four fontanels in the infant and cite their locations.

120) Explain the five functions of the skeletal system.

121) Differentiate among the three types of joints based on structural and functional classification. Provide examples of each type of joint.

122) Explain how atlas and axis are different from other vertebrae. Discuss the roles they play in the body.

123) Discuss the two factors that cause bone remodeling throughout life.

124) List and explain the steps in the repair process of a simple fracture.

- 1) E
- 2) E
- 3) A
- 4) A
- 5) E
- 6) E
- 7) E
- 8) A
- 9) E
- 10) D
- 11) B
- 12) E
- 13) A
- 14) B
- 15) B
- 16) C
- 17) D
- 18) E
- 19) E
- 20) C
- 21) C
- 22) C
- 23) B
- 24) E
- 25) C
- 26) D
- 27) B
- 28) E
- 29) A
- 30) A
- 31) E
- 32) D
- 33) E
- 34) A
- 35) A
- 36) D
- 37) D
- 38) D
- 39) D
- 40) E
- 41) B
- 42) D
- 43) B
- 44) C
- 45) A
- 46) H
- 47) Z
- 48) R
- 49) gout
- 50) rickets
- 51) glenoid cavity

- 52) D
- 53) N
- 54) foramen
- 55) I
- 56) C
- 57) calcaneus
- 58) tuberosity
- 59) hinge
- 60) simple or closed
- 61) E
- 62) short
- 63) O
- 64) Q
- 65) cribriform plate
- 66) Osteoclasts
- 67) D
- 68) L
- 69) H
- 70) mandible
- 71) 1. Diaphysis—the shaft of the long bone: a) it is made of compact bone; b) it is covered by a fibrous connective tissue membrane, the periosteum. The periosteum is securely held to the compact bone beneath by connective tissue fibers called perforating or Sharpey's fibers; c) it contains a hollow cavity called the medullary cavity that stores adipose tissue as yellow marrow, and is the site of hematopoiesis (red blood cell formation) in infants when it contains red marrow.  
2. Epiphyses—somewhat rounded ends of the long bone: each epiphysis has an outer layer of compact bone covering an inner core of spongy bone. The external surface is covered by a layer of hyaline cartilage, instead of a periosteum, called articular cartilage. This provides for a smooth, gliding joint.  
3. Epiphyseal line/plate—the junction between the epiphyses and the diaphysis. During growth years is made of hyaline cartilage and is called the epiphyseal plate. It causes the lengthwise growth of the bone. By the end of puberty, long bones stop lengthening when the plate has been replaced by bone. It now appears as a thin bony ridge and is called the epiphyseal line.
- 72) A
- 73) temporal
- 74) hematopoiesis
- 75) X
- 76) appositional
- 77) FALSE
- 78) FALSE
- 79) TRUE
- 80) FALSE
- 81) FALSE
- 82) TRUE
- 83) TRUE
- 84) FALSE
- 85) TRUE
- 86) FALSE
- 87) TRUE
- 88) FALSE
- 89) TRUE
- 90) FALSE
- 91) B
- 92) A

- 93) A
- 94) B
- 95) A
- 96) A
- 97) A
- 98) A
- 99) A
- 100) B
- 101) A
- 102) A
- 103) A
- 104) A
- 105) A
- 106) A
- 107) A
- 108) A
- 109) C
- 110) A
- 111) B
- 112) A
- 113) A
- 114) A
- 115) A

116) The epiphyseal plate is a flat plate of hyaline cartilage seen in young growing bone. Epiphyseal plates cause the lengthwise growth of long bone. Since this child is still growing and has not completed puberty, she may expect impaired growth in that one epiphyseal plate. Lucky for Sarah, there is an epiphyseal plate located at both the distal and proximal ends of the femur. The healthy distal plate can continue to grow.

117) The female pelvis:

- a. has a larger and more circular inlet.
- b. is shallower than the male pelvis.
- c. has lighter and thinner bones.
- d. has a shorter and less curved sacrum.
- e. has a more rounded pubic arch.
- f. has shorter ischial spines that are also farther apart.

- 118) 1. Osteoclasts are giant bone-destroying cells that break down bone matrix and release calcium ions into the blood. They are activated by a hormone called parathyroid hormone (PTH).
2. Osteoblasts are bone-forming cells. They add bone tissue to growing bones.
3. Osteocytes are mature bone cells. In their former lives, they were osteoblasts that laid down bone matrix, but became trapped in it.

119) Fontanelles are fibrous membranes connecting the cranial bones of the infant skull.

They serve two functions: they allow the fetal skull to be compressed slightly during childbirth and they allow the infant brain to grow during the later part of pregnancy and early infancy. The four fontanelles are:

- 1. Anterior fontanel—this is the largest fontanel and is located between the parietal bones and the frontal bone. It is diamond-shaped.
  - 2. Mastoid fontanel—superior to the posterior part of the temporal bone on a lateral view of the cranium.
  - 3. Posterior fontanel—smaller, triangular fontanel located posteriorly on the lateral view of the cranium.
  - 4. Sphenoidal fontanel—superior to the anterior part of the temporal bone on the lateral view of the cranium.
- 120) 1. Support—the skeletal system forms the body's internal structural framework. The bones of the legs act as pillars to support the body trunk when we stand, and the rib cage supports the thoracic wall.
2. Movement—the skeletal muscles, attached to bones by tendons, use the bones as levers to move the body and its parts.
3. Protection—bones, such as the skull, thorax, and pelvis, protect the enclosed soft body organs.

4. Fat is stored in the internal cavities of bones. Bones also serve as a storehouse for minerals, the most important being calcium and phosphorus.

5. Hematopoiesis—blood cell formation occurs within the red marrow of certain bones.

- 121) 1. Synarthroses are immovable joints. These joints are structurally classified as fibrous joints since the bones are united by fibrous tissue. Skull sutures are one example of a fibrous joint.
2. Amphiarthroses are slightly movable joints. These joints are structurally classified as cartilaginous joints since the bone ends are connected by cartilage. The pubic symphysis and intervertebral joints are two examples.
3. Diarthroses are freely movable joints. These joints are structurally classified as synovial joints since the articulating bone ends are separated by a joint cavity containing synovial fluid. There are many examples of synovial joints, including the elbow, knee, and shoulder.
- 122) 1. Unlike all other vertebra, atlas (C1) has no body. Axis (C2) has a large process called the dens or odontoid process.
2. The structural differences of these two vertebrae allow you to rotate your head from side to side to indicate "no." The joint between these two vertebrae is a pivot joint.
- 123) 1. Calcium levels in the bloodstream determine when bone is to be broken down. When calcium levels in the bloodstream drop below normal, the parathyroid glands produce and release parathyroid hormone (PTH) into the blood. PTH activates osteoclasts (giant bone-destroying cells in bone) to break down bone and release calcium into the blood. Conversely, when calcium levels in the bloodstream are too high, osteoblasts (bone-forming cells in bone) are activated and calcium is deposited in bone matrix as hard calcium salts.
2. Stresses of muscle pull and gravity acting on the skeleton determine where bone matrix is to be broken down or formed so that the skeleton can remain strong for as long as possible. Long bones grow in length and in thickness as the body increases in size and as a result of the activity of bulky muscles. At these sites, osteoblasts (bone-forming cells) lay down new matrix and become trapped within it. Once they are trapped, they become osteocytes or true bone cells.
- 124) Step 1 is hematoma formation. A hematoma, or bloodfilled swelling, forms when bone breaks and blood vessels rupture. Bone cells are deprived of nutrition and die.
- Step 2 is fibrocartilaginous callus formation. The site of damage experiences growth of new capillaries into the clotted blood and disposal of dead tissue by phagocytes. Connective tissue cells of various types form a mass of repair tissue called fibrocartilage callus. This fibrocartilage callus contains several elements: some cartilage matrix, some bony matrix, and collagen fibers. This fibrocartilage callus acts to splint the broken bone, closing the gap.
- Step 3 is bony callus formation. As more osteoblasts and osteoclasts migrate into the area and multiply, fibrocartilage is gradually replaced by a callus of spongy bone (the bony callus).
- Step 4 is bone remodeling. Over the next few months, bony callus is remodeled in response to the mechanical stresses placed on it, so that it forms a strong, permanent patch at the fracture site.



Exam

Name \_\_\_\_\_

**MULTIPLE CHOICE. Choose the one alternative that best completes the statement or answers the question.**

- 1) The muscle tissue type that consists of single, very long, cylindrical, multinucleate cells with very obvious striations is: 1) \_\_\_\_\_
  - A) skeletal muscle only
  - B) cardiac and smooth muscle
  - C) cardiac and skeletal muscle
  - D) cardiac muscle only
  - E) smooth muscle only
  
- 2) Which one of the following does NOT compress the abdomen: 2) \_\_\_\_\_
  - A) rectus abdominis
  - B) internal oblique
  - C) latissimus dorsi
  - D) external oblique
  - E) transversus abdominis
  
- 3) Neurotransmitters are released upon stimulation from a nerve impulse by the: 3) \_\_\_\_\_
  - A) thick filaments
  - B) motor unit
  - C) axon terminals of the motor neuron
  - D) sarcolemma of the muscle cell
  - E) myofibrils
  
- 4) What type of membrane wraps a fascicle: 4) \_\_\_\_\_
  - A) perimysium
  - B) aponeuroses
  - C) tendons
  - D) epimysium
  - E) endomysium
  
- 5) Which one of the following muscles is involved in abduction of the arm at the shoulder joint: 5) \_\_\_\_\_
  - A) biceps brachii
  - B) triceps brachii
  - C) deltoid
  - D) latissimus dorsi
  - E) pectoralis major
  
- 6) While doing "jumping jacks" during an exercise class, your arms and legs move laterally away from the midline of your body. This motion is called: 6) \_\_\_\_\_
  - A) extension
  - B) adduction
  - C) circumduction
  - D) flexion
  - E) abduction
  
- 7) Which of the following muscles closes the jaw: 7) \_\_\_\_\_
  - A) the frontalis
  - B) the masseter and the temporalis
  - C) the sternocleidomastoid

- D) the masseter
- E) the buccinator

- 8) An elaborate and specialized network of membranes in skeletal muscle cells that function in calcium storage is the: 8) \_\_\_\_\_
- A) sarcolemma
  - B) mitochondria
  - C) sarcoplasmic reticulum
  - D) myofibrillar network
  - E) intermediate filament network
- 9) A sarcomere is: 9) \_\_\_\_\_
- A) the area between two intercalated discs
  - B) the nonfunctional unit of skeletal muscle
  - C) the wavy lines on the cell, as seen in a microscope
  - D) the contractile unit between two Z discs
  - E) a compartment in a myofilament
- 10) A muscle located on the ventral (anterior) side of the body is the: 10) \_\_\_\_\_
- A) occipitalis
  - B) gluteus medius
  - C) gastrocnemius
  - D) latissimus dorsi
  - E) pectoralis major
- 11) Which of the following muscles is not involved in dorsiflexion and/or plantar flexion of the foot: 11) \_\_\_\_\_
- A) gastrocnemius
  - B) extensor digitorum longus
  - C) soleus
  - D) iliopsoas
  - E) tibialis anterior
- 12) During skeletal muscle contraction, myosin cross bridges attach to active sites of: 12) \_\_\_\_\_
- A) the H zone
  - B) Z discs
  - C) actin filaments
  - D) myosin filaments
  - E) thick filaments
- 13) The plasma membrane of a muscle cell is called the: 13) \_\_\_\_\_
- A) myofilament
  - B) sarcomere
  - C) sarcolemma
  - D) sarcoplasm
  - E) sarcoplasmic reticulum
- 14) The gap between the axon terminal of a motor neuron and the sarcolemma of a skeletal muscle cell is called the: 14) \_\_\_\_\_
- A) cross bridge
  - B) motor unit
  - C) neuromuscular junction
  - D) sarcomere

E) synaptic cleft

- 15) Which of these pathways to regenerate ATP during muscle activity is the fastest: 15) \_\_\_\_\_  
A) direct phosphorylation of ADP by creatine phosphate  
B) aerobic respiration  
C) both aerobic respiration and anaerobic glycolysis  
D) oxidative phosphorylation  
E) anaerobic glycolysis and lactic acid formation
- 16) Which of the following muscles inserts on the calcaneus: 16) \_\_\_\_\_  
A) the soleus  
B) the iliopsoas  
C) the tibialis anterior  
D) the sartorius  
E) the semitendinosus
- 17) A nursing infant develops a powerful sucking muscle that adults also use for whistling or blowing a trumpet called the: 17) \_\_\_\_\_  
A) zygomaticus  
B) temporalis  
C) masseter  
D) buccinator  
E) platysma
- 18) Anaerobic glycolysis occurs without: 18) \_\_\_\_\_  
A) glucose  
B) oxygen  
C) lactic acid  
D) ATP  
E) carbon dioxide

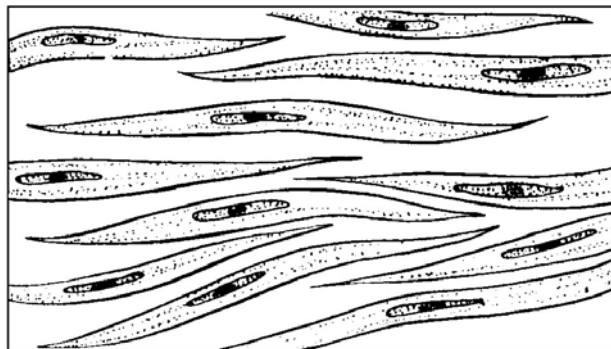

Figure 6.3

- 19) The type of muscle tissue pictured in Figure 6.3 is: 19) \_\_\_\_\_  
A) striated  
B) found only in the heart  
C) skeletal muscle  
D) voluntary  
E) smooth muscle
- 20) Paralysis of which of the following would make an individual unable to flex the thigh: 20) \_\_\_\_\_

- A) biceps femoris
- B) vastus intermedius
- C) vastus lateralis
- D) vastus medialis
- E) iliopsoas and rectus femoris

21) Acetylcholine is: 21) \_\_\_\_\_

- A) an oxygen-binding protein
- B) a component of thick myofilaments
- C) a source of energy for muscle contraction
- D) an ion pump on the postsynaptic membrane
- E) a neurotransmitter that stimulates skeletal muscle

22) Which one of the following is composed of myosin protein: 22) \_\_\_\_\_

- A) light bands
- B) Z discs
- C) thick filaments
- D) thin filaments
- E) all myofilaments

23) Place these structures of the skeletal muscle in order from largest to smallest: 23) \_\_\_\_\_

1. fascicle
2. myofilament
3. muscle fiber (cell)
4. myofibril
5. sarcomere

- A) 1, 3, 4, 5, 2      B) 2, 5, 4, 3, 1      C) 1, 4, 3, 2, 5      D) 3, 1, 2, 4, 5      E) 3, 2, 5, 4, 1

24) A muscle group that works with and assists the action of a prime mover is a(n): 24) \_\_\_\_\_

- A) synergist only
- B) antagonist and fixator
- C) antagonist and synergist
- D) fixator only
- E) antagonist only

25) Which of the following muscles are antagonists: 25) \_\_\_\_\_

- A) vastus medialis and vastus lateralis
- B) biceps brachii and triceps brachii
- C) biceps femoris and biceps brachii
- D) gastrocnemius and soleus
- E) masseter and temporalis

26) Muscle tissue that has involuntary regulation of contraction is: 26) \_\_\_\_\_

- A) skeletal muscle only
- B) cardiac muscle only
- C) cardiac muscle and skeletal muscle
- D) smooth muscle only
- E) cardiac muscle and smooth muscle

27) Which of these muscles is not responsible for flexion or extension of the arm? 27) \_\_\_\_\_

- A) platysma
- B) triceps brachii

- C) biceps brachii
- D) brachialis
- E) latissimus dorsi

- 28) Which one of the following functions do calcium ions perform during skeletal muscle contraction: 28) \_\_\_\_\_
- A) release the inhibition on Z discs
  - B) bind to regulatory proteins on the myosin filaments, changing both their shape and their position on the thick filaments
  - C) increase the action potential transmitted along the sarcolemma
  - D) cause ATP binding to actin
  - E) expose myosin binding sites on the actin
- 29) The striations that give skeletal muscle its characteristic striped appearance are produced, for the most part, by: 29) \_\_\_\_\_
- A) a difference in the thickness of the sarcolemma
  - B) the sarcoplasmic reticulum
  - C) the arrangement of myofilaments
  - D) the "cocked" positions of the heads of the thick filaments
  - E) the T tubules
- 30) Which one of the following muscle actions would NOT be classified as an ISOTONIC contraction: 30) \_\_\_\_\_
- A) tying your shoe
  - B) throwing a ball
  - C) lifting a glass of water to your mouth
  - D) pushing against a stationary wall
  - E) writing a letter
- 31) Sandra is playing the piano for her recital. Which muscle is not involved in the movement of her hands and/or fingers: 31) \_\_\_\_\_
- A) extensor digitorum longus
  - B) extensor carpi radialis
  - C) flexor carpi ulnaris
  - D) flexor carpi radialis
  - E) extensor digitorum
- 32) The mechanical force of contraction is generated by: 32) \_\_\_\_\_
- A) the temporary disappearance of thin filaments
  - B) shortening of the thin filaments
  - C) shortening of the thick filaments
  - D) the "accordion-like" folding of thin and thick filaments
  - E) a sliding of thin filaments past thick ones
- 33) A skeletal muscle twitch differs from a tetanic contraction in that: 33) \_\_\_\_\_
- A) the muscle twitch is a brief and "jerky" movement, while the tetanic contraction is prolonged and continuous
  - B) the tetanic contraction is considered abnormal, while the twitch is a normal muscle response
  - C) the tetanic contraction is caused by a single stimulus, while the twitch is caused by very rapid multiple stimuli
  - D) the muscle twitch is prolonged and continuous while a tetanic contraction is brief and

"jerky"

E) the muscle twitch occurs only in small muscles while a tetanic contraction occurs in large muscle groups

- 34) Which of these events must occur first to trigger the skeletal muscle to generate an action potential and contract: 34) \_\_\_\_\_
- A) acetylcholine (ACh) causes temporary permeability to sodium
  - B) acetylcholinesterase (AChE) breaks down acetylcholine (ACh)
  - C) diffusion of potassium ions out of the cell
  - D) sodium ions rush into the cell
  - E) operation of the sodium-potassium pump
- 35) Creatine phosphate (CP) functions within the muscle cells by: 35) \_\_\_\_\_
- A) forming a chemical compound with actin
  - B) storing energy that will be transferred to ATP to resynthesize ADP as needed
  - C) inducing a conformational change in the myofilaments
  - D) storing energy that will be transferred to ADP to resynthesize ATP as needed
  - E) forming a temporary chemical compound with myosin
- 36) Which of the following does not describe cardiac muscle tissue: 36) \_\_\_\_\_
- A) rhythmic contractions
  - B) involuntary
  - C) striations
  - D) uninucleate
  - E) attached to bones
- 37) Which of the following is NOT a function of the muscular system: 37) \_\_\_\_\_
- A) maintenance of posture
  - B) production of movement
  - C) hematopoiesis
  - D) stabilization of joints
  - E) generation of heat
- 38) The condition of skeletal muscle fatigue can be best explained by: 38) \_\_\_\_\_
- A) a total lack of ATP
  - B) the inability to generate sufficient quantities of ATP due to feedback regulation of synthesis
  - C) the all-or-none law
  - D) inadequate numbers of mitochondria
  - E) insufficient intracellular quantities of ATP due to excessive consumption
- 39) Which one of the following is NOT a criteria generally used in naming muscles: 39) \_\_\_\_\_
- A) number of origins of the muscle
  - B) shape of the muscle
  - C) method of attachment of the muscle to bone
  - D) relative size of the muscle
  - E) action of the muscle
- 40) Which one of the following is the action of the orbicularis oris: 40) \_\_\_\_\_
- A) allows blinking, squinting, and various other protective mechanisms for the eye
  - B) pulls the lower lip down and back
  - C) draws the eyebrows together
  - D) closes the jaw

E) closes, purses, and protrudes the lips

- 41) The axon terminals of a nerve cell and the sarcolemma of a skeletal muscle cell join at the: 41) \_\_\_\_\_  
A) myofibril  
B) motor unit  
C) synaptic cleft  
D) neuromuscular junction  
E) action potential
- 42) Paralysis of which of the following would make an individual unable to flex the knee: 42) \_\_\_\_\_  
A) iliopsoas  
B) hamstring muscle group  
C) sartorius  
D) gastrocnemius  
E) gluteal muscle group
- 43) The insertion of the gluteus maximus is the: 43) \_\_\_\_\_  
A) sacrum            B) ilium            C) femur            D) tibia            E) calcaneus
- 44) The major function of the sarcoplasmic reticulum in skeletal muscle contraction is to: 44) \_\_\_\_\_  
A) make and store phosphocreatine  
B) provide a source of myosin for the contraction process  
C) synthesize actin and myosin myofilaments  
D) regulate intracellular calcium concentration  
E) store ATP
- 45) Which of the following muscles adducts the thigh: 45) \_\_\_\_\_  
A) peroneus muscles  
B) adductor muscles  
C) gluteus maximus  
D) quadriceps group  
E) sartorius

**SHORT ANSWER. Write the word or phrase that best completes each statement or answers the question.**

*Fill in the blank or provide a short answer:*

- 46) Only \_\_\_\_\_ muscle cells are cylindrical and multinucleated. 46) \_\_\_\_\_
- 47) The \_\_\_\_\_ zone of a sarcomere contains no actin filaments while the skeletal muscle is at rest (noncontractile state). 47) \_\_\_\_\_
- 48) The \_\_\_\_\_ of a muscle is attached to the immovable or less movable bone. 48) \_\_\_\_\_
- 49) When a skeletal muscle is fully contracted, the \_\_\_\_\_ are closer to the thick filaments. 49) \_\_\_\_\_
- 50) The \_\_\_\_\_ muscle runs deep to the external oblique muscle. 50) \_\_\_\_\_
- 51) Fascicle arrangements produce skeletal muscles with different structures and functional properties, and determine their individual range of motion and power. List the seven different fascicle arrangements of human skeletal muscles and give a specific example of each: 51) \_\_\_\_\_

Fill in the blank or provide a short answer:

52) The gap between the motor neuron and the muscle fiber it supplies at the neuromuscular junction is called the \_\_\_\_\_.

52) \_\_\_\_\_

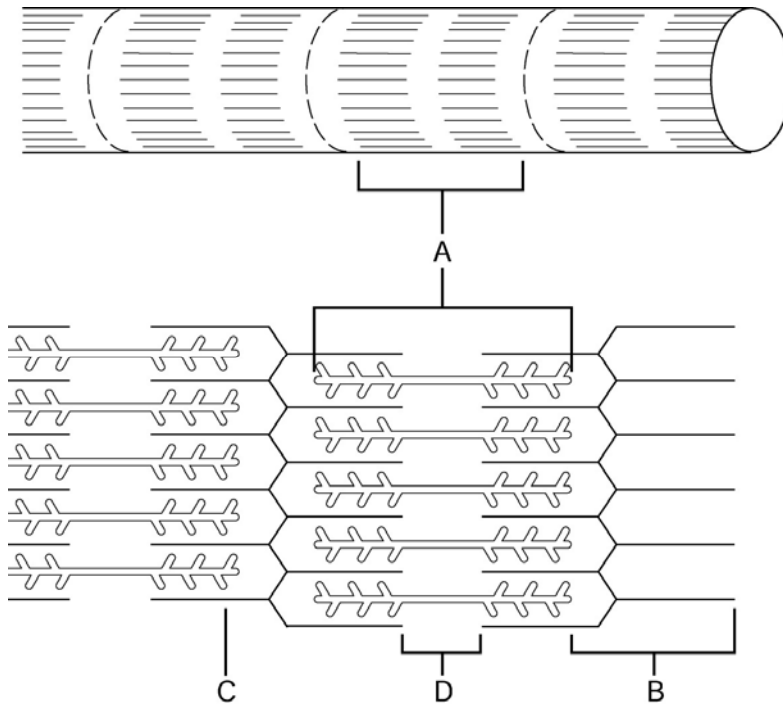

Figure 6.1

Using Figure 6.1, match the following:

53) The lighter central area of the A band is indicated by letter \_\_\_\_\_.

53) \_\_\_\_\_

54) The A band within a skeletal muscle fiber is indicated by letter \_\_\_\_\_.

54) \_\_\_\_\_

55) The I band within a skeletal muscle fiber is indicated by letter \_\_\_\_\_.

55) \_\_\_\_\_

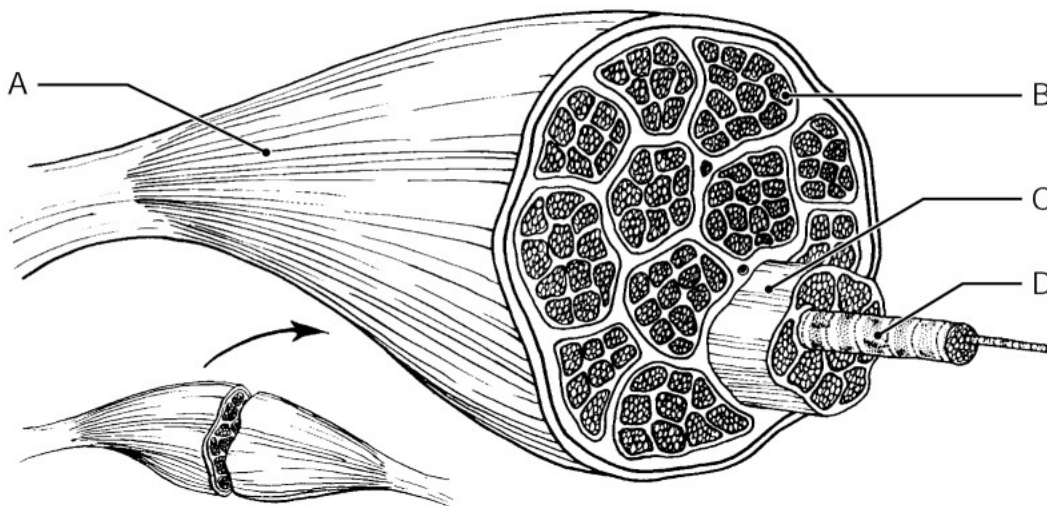

Figure 6.2



Using Figure 6.2, match the following:

- 56) The connective tissue that wraps a fascicle, or bundle of muscle fibers, is indicated by letter \_\_\_\_\_. 56) \_\_\_\_\_

Fill in the blank or provide a short answer:

- 57) The muscle tissue that normally exhibits voluntary contractions is \_\_\_\_\_ muscle. 57) \_\_\_\_\_
- 58) The muscle that has the major responsibility for causing a particular movement is the \_\_\_\_\_. 58) \_\_\_\_\_
- 59) The quadriceps femoris muscle group is composed of the three vastus muscles and the \_\_\_\_\_ muscle. 59) \_\_\_\_\_
- 60) The muscle referred to as the "smiling" muscle because it raised the corners of the mouth upward is the \_\_\_\_\_. 60) \_\_\_\_\_
- 61) An inherited disease that causes muscles to degenerate and atrophy is known as \_\_\_\_\_. 61) \_\_\_\_\_
- 62) The heads of the myosin myofilaments are called \_\_\_\_\_ when they link the thick and thin filaments together during skeletal muscle contraction. 62) \_\_\_\_\_

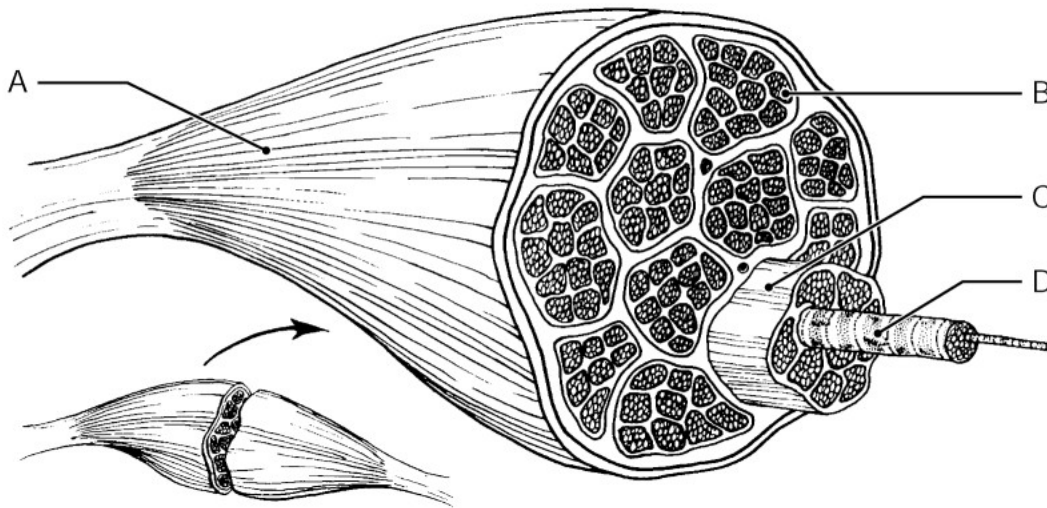

Figure 6.2

Using Figure 6.2, match the following:

- 63) The endomysium that wraps individual muscle fibers is indicated by letter \_\_\_\_\_. 63) \_\_\_\_\_
- 64) List the "five golden rules" of gross skeletal muscle activity. 64) \_\_\_\_\_

Fill in the blank or provide a short answer:

- 65) The arrangement of fascicles in orbicularis oris is \_\_\_\_\_. 65) \_\_\_\_\_
- 66) A smooth, sustained contraction is called \_\_\_\_\_. 66) \_\_\_\_\_
- 67) Skeletal muscle is often attached to bone by strong, cordlike structures called \_\_\_\_\_. 67) \_\_\_\_\_

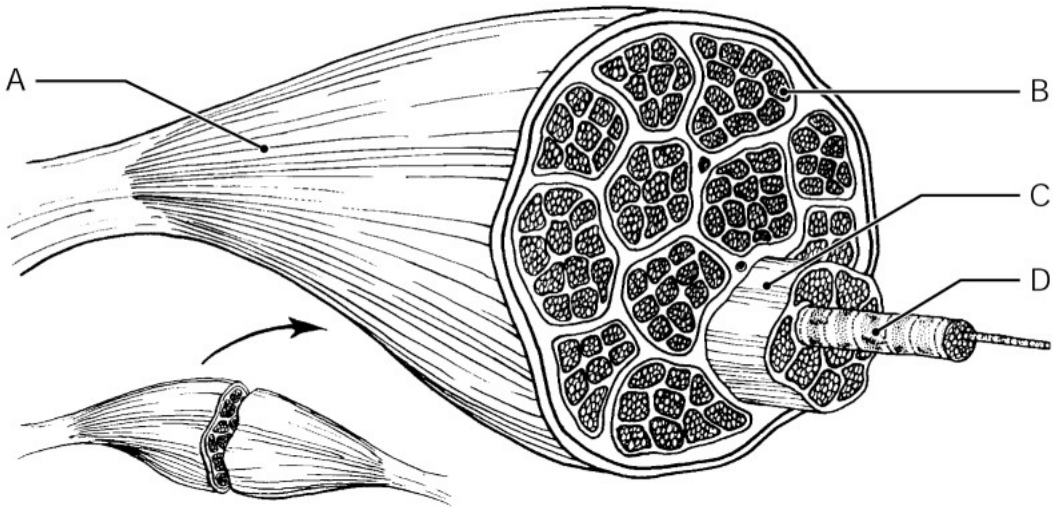

Figure 6.2

Using Figure 6.2, match the following:

68) The connective tissue "overcoat" that wraps the entire muscle is indicated by letter \_\_\_\_\_ 68) \_\_\_\_\_

Fill in the blank or provide a short answer:

69) The movement that is commonly seen in a ball-in-socket joint, that includes a combination of flexion, extension, abduction, and adduction, is called \_\_\_\_\_ 69) \_\_\_\_\_

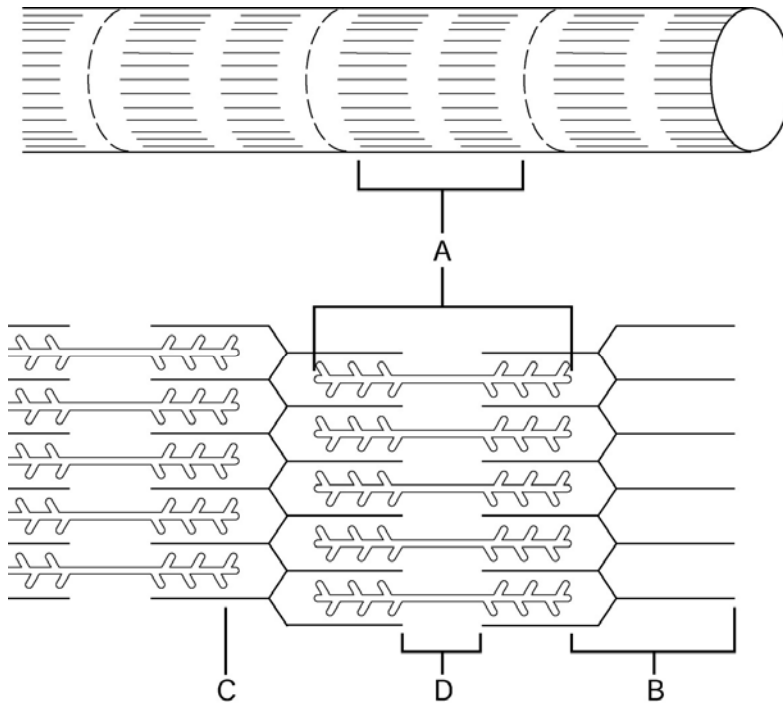

Figure 6.1

Using Figure 6.1, match the following:

70) The thin filament is indicated by letter \_\_\_\_\_.

70) \_\_\_\_\_

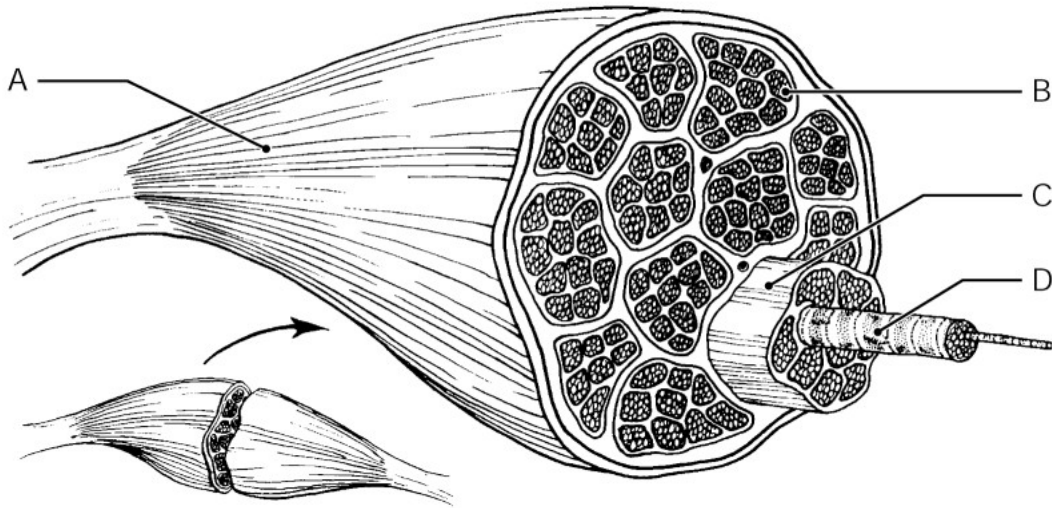

Figure 6.2

Using Figure 6.2, match the following:

71) The muscle fiber is indicated by letter \_\_\_\_\_.

71) \_\_\_\_\_

Fill in the blank or provide a short answer:

72) The only energy source that can be used to directly power muscle activity is \_\_\_\_\_.

72) \_\_\_\_\_

73) Only \_\_\_\_\_ muscle cells possess intercalated discs.

73) \_\_\_\_\_

**TRUE/FALSE. Write 'T' if the statement is true and 'F' if the statement is false.**

74) An aponeurosis is a ropelike piece of muscle fascia that forms indirect connections to muscles of the leg.

74) \_\_\_\_\_

75) Skeletal muscles need nerve stimulation for contraction to occur.

75) \_\_\_\_\_

76) The deepest muscle of the abdominal wall is the transversus abdominis.

76) \_\_\_\_\_

77) Thick filaments are made of a protein called actin.

77) \_\_\_\_\_

78) One of the important functions of skeletal muscle is to generate heat.

78) \_\_\_\_\_

79) A sustained partial contraction of skeletal muscle is called muscle tone.

79) \_\_\_\_\_

80) The insertion of the biceps brachii muscle is on the radius.

80) \_\_\_\_\_

81) Supination and pronation refer to up and down movements of the foot at the ankle.

81) \_\_\_\_\_

82) Dorsiflexion and plantar flexion are synergistic actions.

82) \_\_\_\_\_

83) A muscle twitch results when the muscle is stimulated so rapidly that no evidence of relaxation is seen.

83) \_\_\_\_\_

- 84) A prime mover of the arm that acts in adduction is the deltoid. 84) \_\_\_\_\_
- 85) A nerve cell and all the muscle cells that it stimulates are referred to as a motor unit. 85) \_\_\_\_\_
- 86) The biceps brachii muscle is named for the two heads that originate from the shoulder girdle. 86) \_\_\_\_\_
- 87) A contraction in which a skeletal muscle does not shorten but its tension increases is called isometric. 87) \_\_\_\_\_
- 88) The neurotransmitter used by the nervous system to activate skeletal muscle cells is acetylcholine. 88) \_\_\_\_\_
- 89) The epimysium covers individual muscle fibers. 89) \_\_\_\_\_
- 90) There are 206 skeletal muscles in the human body. 90) \_\_\_\_\_
- 91) Skeletal muscle is considered involuntary because it is the only type of muscle usually subject to conscious control. 91) \_\_\_\_\_
- 92) Cardiac muscle fibers are relatively short, tapering cells within a single centrally located nucleus. 92) \_\_\_\_\_
- 93) When a muscle fiber contracts, the I bands diminish in size, the H zones disappear, and the A bands move closer together but do not diminish in length. 93) \_\_\_\_\_
- 94) Plantar flexion at the ankle joint is accomplished by the tibialis anterior muscle. 94) \_\_\_\_\_
- 95) The effect of the neurotransmitter on the muscle cell membrane is to temporarily modify its permeability of ions such as Na<sup>+</sup> and K<sup>+</sup>. 95) \_\_\_\_\_
- 96) Lactic acid results from aerobic respiration. 96) \_\_\_\_\_

**MATCHING. Choose the item in column 2 that best matches each item in column 1.**

*Match the following:*

- |  |                     |           |
|--|---------------------|-----------|
| 97) The distance between two Z discs                         | A) myosin filaments | 97) _____ |
| 98) The type of filament that is studded with myosin heads   | B) Z discs          | 98) _____ |
| 99) Actin filaments are anchored to these disclike membranes | C) sarcomere        | 99) _____ |

*Match the following:*

- |  |                        |            |
|--|------------------------|------------|
| 100) A reserve, high-energy compound used to convert ADP to ATP by the transfer of a high-energy phosphate group | A) creatine phosphate  | 100) _____ |
|  | B) aerobic respiration |            |

*Match the following:*

- |  |              |          |
|--|--------------|----------|
| 101) The movement of a limb toward the | body midline | A) adduc |
|--|--------------|----------|

tion 101) \_\_\_\_\_  
\_\_\_\_\_

*Match the following:*

102) Both actin and myosin are found in this band

A) I band

102) \_\_\_\_\_

B) A band

*Match the following:*

103) Destroys acetylcholine (ACh)

A) potassium ions

103) \_\_\_\_\_

B) enzymes

*Match the following:*

104) Type of movement that results when the forearm rotates laterally so that the palm faces anteriorly

A) supination

104) \_\_\_\_\_

B) pronation

105) Type of movement that results when the forearm rotates medially so the palm faces posteriorly

105) \_\_\_\_\_

*Match the following:*

106) Lighter central portion of the A band

A) H zone

106) \_\_\_\_\_

*Match the following:*

107) The movement of a bone around its longitudinal axis

A) rotation

107) \_\_\_\_\_

*Match the following:*

108) Otherwise known as thick filaments

A) myosin filaments

108) \_\_\_\_\_

B) actin filaments

*Match the following:*

109) The movement of a limb away from the body midline

A) abduction

109) \_\_\_\_\_

B) flexion

110) Primary action of the rectus abdominis

110) \_\_\_\_\_

*Match the following:*

111) Neurotransmitter substance released at motor end plates by the motor neuron

A) enzymes

111) \_\_\_\_\_

B)

acetylcholine

*Match the following:*

112) Tiny contractile unit that shortens during muscle contraction

A) sarcomere

112) \_\_\_\_\_

*Match the following:*

113) Serves as the actual "go" signal for muscle contraction

A) sodium ions

113) \_\_\_\_\_

B) calcium ions

*Match the following:*

114) Primary action of the adductor muscles

A) adduction

114) \_\_\_\_\_

B) extension

115) Type of movement that increases the angle of the joint

115) \_\_\_\_\_

*Match the following:*

116) A metabolic pathway that produces water, carbon dioxide, and ATP, and provides for a large amount of ATP per glucose because oxygen is used

A) aerobic respiration

116) \_\_\_\_\_

B) anaerobic respiration

*Match the following:*

117) Primary action of the deltoid

A) abduction

117) \_\_\_\_\_

*Match the following:*

118) Normally stored in the sarcoplasmic reticulum

A) acetylcholine

118) \_\_\_\_\_

B) calcium ions

*Match the following:*

119) Primary action of the erector spinae

A) extension

119) \_\_\_\_\_

*Match the following:*

120) Contains only the actin filaments

A) A band

120) \_\_\_\_\_

B) I band

*Match the following:*

121) Type of movement that decreases the angle of the joint

A) flexion

121) \_\_\_\_\_

**ESSAY. Write your answer in the space provided or on a separate sheet of paper.**

- 122) Explain the difference between a motor unit and a neuromuscular junction.
- 123) Explain how isometric and isotonic contractions differ, using examples of each.
- 124) Describe the events that occur from the time that a motor neuron releases acetylcholine at the neuromuscular junction until muscle cell contraction occurs.
- 125) Compare skeletal, smooth, and cardiac muscles as to their body location, microscopic anatomy, regulation of contraction, speed of contraction, and rhythmicity.
- 126) Explain the steps in the sliding filament theory of muscle contraction, following the spreading of an action potential along the sarcolemma.
- 127) List the seven criteria that are used in naming muscles and give an example of each.
- 128) What is the effect of aging on skeletal muscles?
- 129) Explain how muscle movements mature in a baby, using examples of each.

- 1) A
- 2) C
- 3) C
- 4) A
- 5) C
- 6) E
- 7) B
- 8) C
- 9) D
- 10) E
- 11) D
- 12) C
- 13) C
- 14) E
- 15) E
- 16) A
- 17) D
- 18) B
- 19) E
- 20) E
- 21) E
- 22) C
- 23) A
- 24) A
- 25) B
- 26) E
- 27) A
- 28) E
- 29) C
- 30) D
- 31) A
- 32) E
- 33) A
- 34) A
- 35) D
- 36) E
- 37) C
- 38) E
- 39) C
- 40) E
- 41) D
- 42) B
- 43) C
- 44) D
- 45) B
- 46) skeletal
- 47) H
- 48) origin
- 49) Z discs
- 50) internal oblique
- 51) 1. Circular—orbicularis oris, orbicularis oculi



- 2. major
- Con 3. Parallel—sartorius
- verg 4. Unipennate—extensor digitorum longus
- ent— 5. Multipennate—deltoid
- pecto 6. Fusiform—biceps brachii
- ralis 7. Bipennate—rectus femoris

52) synaptic cleft

53) D

54) A

55) B

56) C

57) skeletal

58) prime mover

59) rectus femoris

60) zygomaticus

61) muscular dystrophy

62) cross bridges

63) B

64) 1. With few exceptions, all muscles cross at least one joint.

2. Typically, the bulk of the muscle lies proximal to the joint crossed.

3. All muscles have at least two attachments: the origin and the insertion.

4. Muscles can only pull: they never push.

5. During contraction, the muscle insertion moves toward the origin.

65) circular

66) tetanus

67) tendons

68) A

69) circumduction

70) C

71) D

72) ATP

73) cardiac

74) FALSE

75) TRUE

76) TRUE

77) FALSE

78) TRUE

79) TRUE

80) FALSE

81) FALSE

82) FALSE

83) FALSE

84) FALSE

85) TRUE

86) TRUE

87) TRUE

88) TRUE

89) FALSE

90) FALSE

91) FALSE

92) FALSE

93) TRUE

- 94) FALSE  
95) TRUE  
96) FALSE  
97) C  
98) A  
99) B  
100) A  
101) A  
102) B  
103) B  
104) A  
105) B  
106) A  
107) A  
108) A  
109) A  
110) B  
111) B  
112) A  
113) B  
114) A  
115) B  
116) A  
117) A  
118) B  
119) A  
120) B  
121) A  
122) 1. The motor unit is the one neuron and all of the skeletal muscle cells it stimulates.  
2. The neuromuscular junction occurs between the axon terminals of one neuron and the sarcolemma of a skeletal muscle cell.  
123) 1. Isometric contractions are contractions in which the muscles do not shorten. An example of an isometric contraction is pushing against a wall with bent elbows. The muscles cannot shorten since the wall doesn't move.  
2. Isotonic contractions occur when muscles shorten and movement occurs due to the sliding of the myofilaments. Flexion and extension of the arm are just two examples of isotonic contractions.  
124) Acetylcholine is released, which diffuses through the synaptic cleft and attaches to receptors on the sarcolemma. The sarcolemma permeability to sodium ions increases briefly, causing sodium ions to rush into the muscle cell, which changes the electrical conditions of the resting sarcolemma. An action potential is initiated and sweeps over the entire sarcolemma. Calcium ions are released from storage areas inside the sarcoplasmic reticulum of the muscle cell. They attach to the myofilaments, which triggers the sliding of the myofilaments and causes a muscle cell contraction.  
125) Body location—skeletal muscle is attached to bones or to skin (some facial muscles); cardiac muscle is located in the walls of the heart; smooth muscle is found in the walls of hollow visceral organs (other than the heart).  
Microscopic anatomy—skeletal muscle consists of very long, cylindrical, multinucleated cells with very obvious striations; cardiac muscle consists of branching chains of cells that are uninucleated and possess striations; smooth muscle consists of single fusiform uninucleated cells that lack striations.  
Regulation of contraction—skeletal muscle is voluntary via nervous system controls, but this normal voluntary control can be overridden by involuntary reflex arcs (as explained in later chapters); cardiac muscle is involuntary via the heart pacemaker, nervous system controls, and hormones; smooth muscle is involuntary via nervous system controls, hormones, other chemicals, and stretching.  
Speed of contraction—skeletal muscle is slow to fast; cardiac muscle is slow; smooth muscle is the slowest.  
Rhythmicity—skeletal muscle is arrhythmic; cardiac muscle is rhythmic; smooth muscle is sometimes rhythmic.

- 126) An action potential triggers the sarcoplasmic reticulum to release calcium ions into the sarcoplasm of the muscle cell. The calcium ions bind to regulatory proteins on the actin filaments, changing both their shape and their position on the actin filaments. This action allows myosin receptor sites on the thin actin filaments to become exposed. The myosin heads attach to the myosin binding sites on the actin filaments. Energized by ATP, the myosin heads swivel toward the center of the sarcomere, attaching and detaching several times. In the process the thin actin filaments are pulled toward the center of the sarcomere. As this event occurs simultaneously in sarcomeres throughout the cell, the muscle cell shortens. When the action potential ends, the calcium ions are reabsorbed back into the sarcoplasmic reticulum storage areas, causing the regulatory proteins to resume their original shape and position. Since the myosin heads now have nothing to attach to, the muscle cell relaxes and returns to its original length.
- 127) 1. Direction of the muscle fibers (e.g., external oblique)  
2. Relative size of the muscle (e.g., maximus, minimus, longus)  
3. Location of the muscle (e.g., temporalis, frontalis)  
4. Number of origins (e.g., biceps, triceps, quadriceps)  
5. Location of the muscle's origin and insertion (e.g., the sternocleidomastoid muscle has its origin on the sternum [sterno] and clavicle [cleido] and inserts on the mastoid process of the temporal bone)  
6. Shape of the muscle (e.g., the deltoid muscle is roughly triangular—deltoid means "triangular")  
7. Action of the muscle (e.g., the adductor muscles of the thigh all bring about its adduction, and the extensor muscles of the wrist all extend the wrist)
- 128) With aging, the amount of connective tissue in muscle increases and the amount of skeletal muscle tissue decreases, thus the muscles become stringier (more sinewy). Since skeletal muscle represents a larger portion of body weight, it begins to decline in elderly persons as this normal loss of muscle mass occurs. Another result of the loss in muscle mass is a decrease in muscle strength—strength decreases by about 50% by the age of 80. Regular exercise can help offset the effects of aging on the muscular system, and frail elders who begin to "pump iron" can rebuild muscle mass and significantly increase their functional strength.
- 129) 1. Muscle development proceeds in a cephalic/caudal direction. For instance, babies can raise their heads before they can walk.  
2. Muscle control proceeds in a proximal/distal direction. For instance, babies can perform gross movements like wave "bye-bye" before they can use the pincher grasp to pick up a pin.

Exam

Name \_\_\_\_\_

**MULTIPLE CHOICE. Choose the one alternative that best completes the statement or answers the question.**

- 1) The vital centers for the control of visceral activities such as heart rate, breathing, blood pressure, swallowing, and vomiting are located in the: 1) \_\_\_\_\_
  - A) hypothalamus
  - B) pons
  - C) cerebrum
  - D) midbrain
  - E) medulla oblongata
  
- 2) Immediately after an action potential is propagated, which one of the following ions rapidly diffuses out of the cell into the tissue fluid: 2) \_\_\_\_\_
  - A) potassium
  - B) calcium
  - C) sodium
  - D) chloride
  - E) magnesium
  
- 3) The blood-brain barrier is effective against the passage of: 3) \_\_\_\_\_
  - A) nutrients such as glucose
  - B) metabolic waste such as urea
  - C) water
  - D) anesthetics
  - E) alcohol
  
- 4) The sympathetic and parasympathetic nervous systems are subdivisions of the: 4) \_\_\_\_\_
  - A) autonomic nervous system
  - B) voluntary nervous system
  - C) somatic nervous system
  - D) central nervous system
  - E) peripheral nervous system
  
- 5) An action potential: 5) \_\_\_\_\_
  - A) involves the outflux of negative ions to depolarize the membrane
  - B) involves the influx of negative ions to depolarize the membrane
  - C) is initiated by potassium ion movements
  - D) involves the outflux of positive ions to depolarize the membrane
  - E) is essential for nerve impulse propagation
  
- 6) Cell bodies of the sensory neurons of the spinal nerves are located in: 6) \_\_\_\_\_
  - A) the dorsal root ganglia of the spinal cord
  - B) the thalamus
  - C) the hypothalamus
  - D) the ventral root ganglia of the spinal cord
  - E) sympathetic ganglia
  
- 7) The effects of the sympathetic nervous system are essentially opposite of the: 7) \_\_\_\_\_
  - A) motor division
  - B) parasympathetic nervous system
  - C) sensory division

- D) central nervous system
- E) autonomic nervous system

8) Cerebrospinal fluid circulates through all of the following except: 8) \_\_\_\_\_

- A) corpus callosum
- B) lateral ventricles
- C) fourth ventricle
- D) cerebral aqueduct
- E) subarachnoid space

9) Which one of the following is the correct sequence in connective tissue sheaths, going from outermost to innermost layer: 9) \_\_\_\_\_

- A) perineurium, endoneurium, epineurium
- B) epineurium, perineurium, endoneurium
- C) perineurium, epineurium, endoneurium
- D) epineurium, endoneurium, perineurium
- E) endoneurium, epineurium, perineurium

10) Sally has a brain injury; she knows what she wants to say but can't vocalize the words. The part of her brain that deals with the ability to speak is the: 10) \_\_\_\_\_

- A) central sulcus
- B) Broca's area
- C) primary motor area
- D) longitudinal fissure
- E) gyrus

11) Which one of the following is the correct sequence of events that follows a threshold potential: 11) \_\_\_\_\_

1. the membrane becomes depolarized
2. sodium channels open and sodium ions diffuse inward
3. the membrane becomes repolarized
4. potassium channels open and potassium ions diffuse outward while sodium is actively transported out of the cell

A) 2, 1, 4, 3      B) 3, 2, 4, 1      C) 2, 1, 3, 4      D) 4, 1, 3, 2      E) 1, 2, 4, 3

12) Which one of the following best describes the waxy-appearing material called *myelin*: 12) \_\_\_\_\_

- A) a mass of white lipid material that surrounds the dendrites of a neuron
- B) an outer membrane on a neuroglial cell
- C) a mass of white lipid material that insulates the axon of a neuron
- D) a lipid-protein (lipoprotein) cell membrane on the outside of axons
- E) a mass of white lipid material that surrounds the cell body of a neuron

13) Which of these cells are not a type of neuroglia found in the CNS: 13) \_\_\_\_\_

- A) Schwann cells
- B) oligodendrocytes
- C) ependymal cells
- D) astrocytes
- E) microglia

14) Bipolar neurons are commonly: 14) \_\_\_\_\_

- A) motor neurons
- B) found in the eye and nose
- C) more abundant in adults than in children

- D) called neuroglia
- E) found in ganglia

- 15) Which one of the following statements about aging is most accurate: 15) \_\_\_\_\_
- A) the brain reaches its maximum weight around the seventh decade of life
  - B) synaptic connections are too fixed to permit a great deal of learning after the age of 35
  - C) despite some neuronal loss, an unlimited number of neural pathways are available and ready to be developed; therefore, additional learning can occur throughout life
  - D) increased efficiency of the sympathetic nervous system enhances the ability to learn
  - E) learning throughout the adult and aging years is supported primarily by glial proliferation
- 16) Lobe that contains the primary motor area that enables voluntary control of skeletal muscle movements: 16) \_\_\_\_\_
- A) frontal lobe
  - B) occipital lobe
  - C) parietal lobe
  - D) diencephalon
  - E) temporal lobe
- 17) The elevated ridges of tissue on the surface of the cerebral hemispheres are known as \_\_\_\_\_ while the shallow grooves are termed \_\_\_\_\_. 17) \_\_\_\_\_
- A) sulci; gyri
  - B) tracts; ganglia
  - C) ganglia; gyri
  - D) gyri; sulci
  - E) receptors; effectors
- 18) An action potential is caused by an influx of these ions into the cell: 18) \_\_\_\_\_
- A) both potassium and sodium
  - B) potassium
  - C) sodium
  - D) magnesium
  - E) calcium
- 19) The function of the olfactory nerve concerns: 19) \_\_\_\_\_
- A) smell
  - B) chewing
  - C) vision
  - D) eye movement
  - E) hearing
- 20) The gap between two communicating neurons is termed: 20) \_\_\_\_\_
- A) node of Ranvier
  - B) synaptic cleft
  - C) effector
  - D) cell body
  - E) Schwann cell
- 21) Which of the nerves plexuses originates from ventral rami <sup>L1-L4</sup>: 21) \_\_\_\_\_
- A) brachial
  - B) lumbar
  - C) sacral
  - D) spinal
  - E) cervical
- 22) The area of the brain stem that plays a role in consciousness and the awake/sleep cycles is the: 22) \_\_\_\_\_

- A) cerebellum
- B) thalamus
- C) reticular activating system (RAS)
- D) pineal gland
- E) limbic system

- 23) A neuron with a cell body located in the CNS whose primary function is connecting other neurons is called a(n): 23) \_\_\_\_\_
- A) efferent neuron
  - B) glial cell
  - C) afferent neuron
  - D) satellite cell
  - E) association neuron
- 24) Afferent nerves are called \_\_\_\_\_, and motor nerves are called \_\_\_\_\_. 24) \_\_\_\_\_
- A) peripheral nerves; cranial nerves
  - B) sensory nerves; efferent nerves
  - C) cranial nerves; peripheral nerves
  - D) motor nerves; sensory nerves
  - E) mixed nerves; motor nerves
- 25) Loss of muscle coordination results from damage to the: 25) \_\_\_\_\_
- A) hypothalamus
  - B) cerebrum
  - C) midbrain
  - D) cerebellum
  - E) thalamus
- 26) The olfactory area is found within the: 26) \_\_\_\_\_
- A) occipital lobe
  - B) parietal lobe
  - C) frontal lobe
  - D) temporal lobe
  - E) pyramidal tract
- 27) The sciatic nerve is the largest nerve in the body resulting from a combination of which two nerves: 27) \_\_\_\_\_
- A) pudendal and femoral nerves
  - B) pudendal and common peroneal nerves
  - C) pudendal and tibial nerves
  - D) common fibular and tibial nerves
  - E) femoral and tibial nerves
- 28) The substance that is released at axonal endings to propagate a nervous impulse is called: 28) \_\_\_\_\_
- A) an ion
  - B) an action potential
  - C) the sodium-potassium pump
  - D) a neurotransmitter
  - E) nerve glue
- 29) Impulse conduction is fastest in neurons that are: 29) \_\_\_\_\_
- A) sensory

- B) unmyelinated
- C) cerebral
- D) motor
- E) myelinated

- 30) Which one of the following represents the correct sequence from outermost to innermost layers of the meninges: 30) \_\_\_\_\_
- A) dura mater, arachnoid mater, pia mater
  - B) pia mater, dura mater, arachnoid mater
  - C) arachnoid mater, dura mater, pia mater
  - D) dura mater, pia mater, arachnoid mater
  - E) pia mater, arachnoid mater, dura mater
- 31) The nerve that contains sensory fibers that are involved in hearing is: 31) \_\_\_\_\_
- A) cranial nerve VIII
  - B) cranial nerve II
  - C) cranial nerve IX
  - D) cranial nerve III
  - E) cranial nerve V
- 32) The diffusion of potassium ions out of a neuron causes it to experience: 32) \_\_\_\_\_
- A) repolarization
  - B) an action potential
  - C) a nerve impulse
  - D) a graded potential
  - E) depolarization
- 33) Damage to this nerve results in "wristdrop," the inability to extend the hand at the wrist: 33) \_\_\_\_\_
- A) obturator
  - B) radial
  - C) axillary
  - D) phrenic
  - E) femoral
- 34) Spinal nerves exiting the cord from the level of L<sub>4</sub> to S<sub>4</sub> form the: 34) \_\_\_\_\_
- A) lumbar plexus
  - B) sacral plexus
  - C) femoral plexus
  - D) obturator plexus
  - E) thoracic plexus
- 35) Which of the following is a traumatic brain injury: 35) \_\_\_\_\_
- A) aphasia
  - B) cerebral edema
  - C) cerebrovascular accident (CVA)
  - D) Parkinson's disease
  - E) Alzheimer's disease
- 36) The peripheral nervous system consists of: 36) \_\_\_\_\_
- A) the spinal and cranial nerves
  - B) the brain and spinal cord
  - C) spinal nerves only
  - D) cranial nerves only
  - E) the brain only
- 37) The neuron processes that normally receive incoming stimuli are called: 37) \_\_\_\_\_



- A) Schwann cells
- B) dendrites
- C) neurolemmas
- D) satellite cells
- E) axons

- 38) Which of the nerve plexuses serves the shoulder and arm: 38) \_\_\_\_\_  
A) sacral            B) cervical            C) phrenic            D) lumbar            E) brachial
- 39) Preparing the body for the "fight-or-flight" response during threatening situations is the role of the: 39) \_\_\_\_\_  
A) sympathetic nervous system  
B) somatic nervous system  
C) cerebrum  
D) afferent nervous system  
E) parasympathetic nervous system
- 40) The cerebrospinal fluid: 40) \_\_\_\_\_  
A) enters the four ventricles after filling and circulating through the subarachnoid space  
B) is secreted by the arachnoid villi  
C) is identical in composition to whole blood  
D) is secreted mostly by the ependymal cells lining the brain ventricles  
E) is continually formed mostly by the choroid plexuses
- 41) The term *central nervous system* refers to the: 41) \_\_\_\_\_  
A) spinal cord and spinal nerves  
B) autonomic and peripheral nervous systems  
C) brain, spinal cord, and cranial nerves  
D) brain and cranial nerves  
E) brain and spinal cord
- 42) Which one of these effectors is NOT directly controlled by the autonomic nervous system: 42) \_\_\_\_\_  
A) smooth muscle  
B) cardiac muscle  
C) most glands  
D) skeletal muscle  
E) abdominal organs
- 43) Sympathetic nervous system stimulation causes: 43) \_\_\_\_\_  
A) increased blood glucose, decreased GI peristalsis, and increased heart rate and blood pressure  
B) decreased blood glucose, increased GI peristalsis, and decreased heart rate and blood pressure  
C) increased blood glucose, increased GI peristalsis, and decreased heart rate and blood pressure  
D) decreased blood glucose, decreased GI peristalsis, and decreased heart rate and blood pressure  
E) decreased blood glucose, increased GI peristalsis, and increased heart rate and blood pressure
- 44) In contrast to the somatic nervous system, the autonomic nervous system: 44) \_\_\_\_\_  
A) stimulates its effector cells

- B) has centers in the brain and spinal cord
- C) has both afferent and efferent fibers
- D) has two motor neurons
- E) has two afferent neurons

- 45) Which of the following is the correct sequence in a typical reflex arc: 45) \_\_\_\_\_
- A) receptor, afferent neuron, efferent neuron, integration center, effector
  - B) effector, efferent neuron, integration center, afferent neuron, receptor
  - C) receptor, afferent neuron, integration center, efferent neuron, effector
  - D) effector, afferent neuron, integration center, efferent neuron, receptor
  - E) receptor, efferent neuron, integration center, afferent neuron, effector
- 46) The ability to respond to a stimulus is termed: 46) \_\_\_\_\_
- A) polarized
  - B) depolarized
  - C) irritability
  - D) all-or-none response
  - E) conductivity
- 47) Which of the following effects is characteristic of the parasympathetic nervous system: 47) \_\_\_\_\_
- A) increases metabolic rate
  - B) stimulates sweat glands to produce perspiration
  - C) decreases heart rate
  - D) decreases urine output
  - E) decreases activity of the digestive system
- 48) Which of the following sensory receptors is a touch receptor: 48) \_\_\_\_\_
- A) Golgi tendon organ
  - B) Pacinian corpuscle
  - C) Meissner's corpuscle
  - D) muscle spindles
  - E) naked nerve endings
- 49) The midbrain, pons, and medulla oblongata are housed in the: 49) \_\_\_\_\_
- A) diencephalon
  - B) brain stem
  - C) pineal gland
  - D) hypothalamus
  - E) cerebellum
- 50) The gray matter of the spinal cord: 50) \_\_\_\_\_
- A) surrounds the white matter of the spinal cord
  - B) surrounds the central canal
  - C) contains myelinated fiber tracts
  - D) always carries sensory information to the brain
  - E) is made up of the dorsal, lateral, and ventral columns
- 51) Which one of the following is the correct sequence of nerves that exit the spinal cord, going from superior to inferior: 51) \_\_\_\_\_
- A) cervical spinal nerves, lumbar spinal nerves, thoracic spinal nerves, sacral spinal nerves
  - B) cervical spinal nerves, thoracic spinal nerves, sacral spinal nerves, lumbar spinal nerves
  - C) thoracic spinal nerves, cervical spinal nerves, sacral spinal nerves, lumbar spinal nerves

- D) thoracic spinal nerves, cervical spinal nerves, lumbar spinal nerves, sacral spinal nerves
- E) cervical spinal nerves, thoracic spinal nerves, lumbar spinal nerves, sacral spinal nerves

- 52) Collections of nerve cell bodies inside the CNS are called: 52) \_\_\_\_\_
- A) nuclei
  - B) ganglia
  - C) nerves
  - D) tracts
  - E) tracts or ganglia
- 53) Which one of the following describes saltatory conduction: 53) \_\_\_\_\_
- A) is faster than conduction on an unmyelinated fiber
  - B) occurs only if nodes of Ranvier are lacking
  - C) occurs only if the myelin sheath is continuous
  - D) is slower than conduction on an unmyelinated fiber
  - E) occurs only in the absence of axon hillocks
- 54) The Schwann cell forms a myelin sheath around the: 54) \_\_\_\_\_
- A) nucleus
  - B) cell body
  - C) axon
  - D) nodes of Ranvier
  - E) dendrites
- 55) The pituitary gland is most closely associated with the: 55) \_\_\_\_\_
- A) hypothalamus
  - B) medulla oblongata
  - C) pineal gland
  - D) midbrain
  - E) thalamus
- 56) Muscles and glands are: 56) \_\_\_\_\_
- A) effectors
  - B) part of the central nervous system
  - C) part of the peripheral nervous system
  - D) receptors
  - E) myelinated
- 57) White matters refers to myelinated fibers in the: 57) \_\_\_\_\_
- A) SNS
  - B) PNS
  - C) ANS
  - D) CNS
  - E) both ANS and SNS
- 58) Sympathetic division fibers leave the spinal cord in the: 58) \_\_\_\_\_
- A) thoracolumbar region, and the postganglionic fibers secrete acetylcholine
  - B) craniosacral regions, and the postganglionic fibers secrete norepinephrine
  - C) craniosacral region, and the preganglionic fibers secrete norepinephrine
  - D) craniosacral region, and the postganglionic fibers secrete acetylcholine
  - E) thoracolumbar region, and the postganglionic fibers secrete norepinephrine

- 59) Control of temperature, endocrine activity, metabolism, and thirst are functions associated with the: 59) \_\_\_\_\_
- A) thalamus
  - B) cerebellum
  - C) hypothalamus
  - D) medulla oblongata
  - E) cerebrum
- 60) The subarachnoid space lies directly between the: 60) \_\_\_\_\_
- A) arachnoid mater and cerebellum
  - B) arachnoid mater and cerebrum
  - C) skull and arachnoid mater
  - D) arachnoid mater and dura mater
  - E) arachnoid mater and pia mater
- 61) The three major parts of the brain stem are the: 61) \_\_\_\_\_
- A) basal nuclei, pineal body, and choroid plexus
  - B) dura mater, arachnoid mater, and pia mater
  - C) midbrain, pons, and medulla oblongata
  - D) thalamus, epithalamus, and hypothalamus
  - E) cerebrum, cerebellum, and diencephalon

**SHORT ANSWER. Write the word or phrase that best completes each statement or answers the question.**

*Fill in the blank or provide a short answer:*

- 62) Diminished effectiveness of the sympathetic nervous system that can cause a type of low blood pressure during rapid changes in body position (such as when elderly persons stand up quickly after sitting or lying down) is called \_\_\_\_\_. 62) \_\_\_\_\_
- 63) A type of reflex that stimulates the skeletal muscles is called a \_\_\_\_\_ reflex. 63) \_\_\_\_\_
- 64) The gaps between Schwann cells found at regular intervals in peripheral system neurons are called \_\_\_\_\_. 64) \_\_\_\_\_
- 65) When there are fewer positive ions sitting on the inner face of the neuron's plasma membrane than there are on the outer face of the tissue fluid that surrounds it, the membrane is said to be \_\_\_\_\_. 65) \_\_\_\_\_
- 66) The cranial nerve responsible for controlling tongue movements is the \_\_\_\_\_ nerve, number \_\_\_\_\_. 66) \_\_\_\_\_

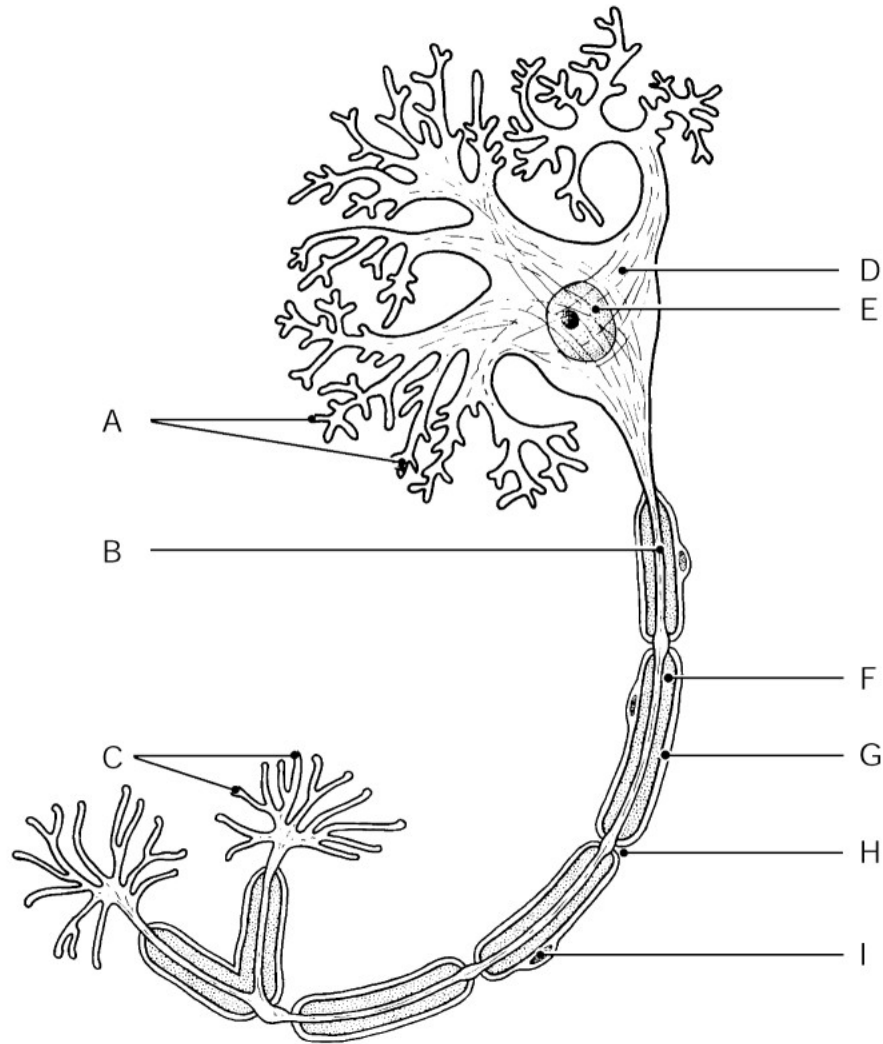

Figure 7.1

Using Figure 7.1, identify the following:

67) The neural processes that convey incoming messages toward the cell body are indicated by letter \_\_\_\_\_.

Fill in the blank or provide a short answer:

68) Cells found in the CNS that cling to neurons and anchor them to blood vessels are called \_\_\_\_\_.

69) The large fiber tract that allows communication between the two cerebral hemispheres is called the \_\_\_\_\_.

70) Myelinated regions of the CNS are referred to as \_\_\_\_\_ matter.

71) The thalamus, hypothalamus, and epithalamus collectively constitute the \_\_\_\_\_.

72) A \_\_\_\_\_ is a type of traumatic brain injury that results in marked tissue destruction.

73) The fissure in the brain that separates the two cerebral hemispheres is called the \_\_\_\_\_.

74) The progressive degenerative disease that results in dementia associated with a shortage of acetylcholine and structural changes in brain areas involving cognition and memory is called \_\_\_\_\_.

74) \_\_\_\_\_

75) The hypothalamus regulates the \_\_\_\_\_ gland.

75) \_\_\_\_\_

76) That part of the Peripheral Nervous System (PNS) that is voluntary and conducts impulses from the Central Nervous System (CNS) to the skeletal muscles is the \_\_\_\_\_ nervous system.

76) \_\_\_\_\_

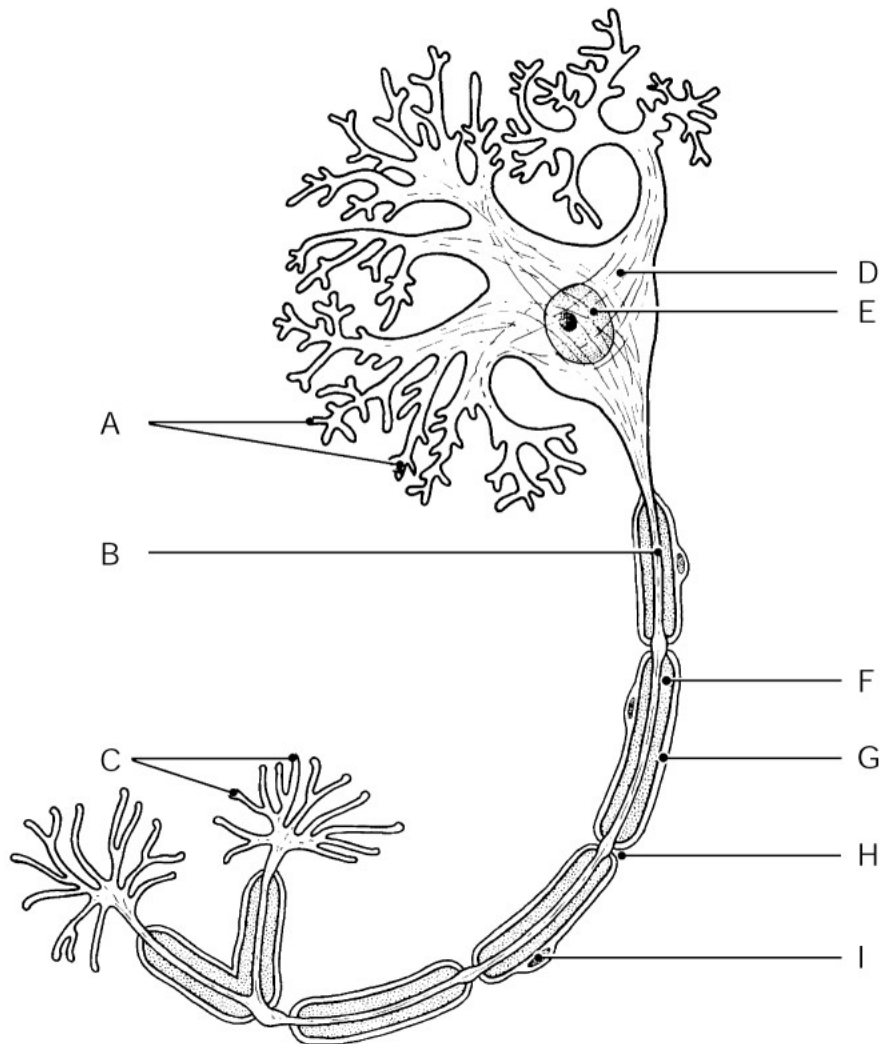

Figure 7.1

Using Figure 7.1, identify the following:

77) The axon is indicated by letter \_\_\_\_\_.

77) \_\_\_\_\_

Fill in the blank or provide a short answer:

78) The cell bodies of the \_\_\_\_\_ neurons are always located within the CNS.

78) \_\_\_\_\_

79) Cranial nerve III is known as the \_\_\_\_\_ nerve.

79) \_\_\_\_\_

80) The autonomic nervous system is also referred to as the \_\_\_\_\_ nervous system since it controls

\_\_\_\_\_

activities 80)  
of  
smooth  
and  
cardiac  
muscles  
and  
glands.

—  
—  
—  
—  
—

81) The only major nerve out of the cervical plexus that supplies the diaphragm and muscles of the shoulder and neck is the \_\_\_\_\_ nerve. 81) \_\_\_\_\_

82) One of the last areas of the CNS to mature is the \_\_\_\_\_, which regulates body temperature. 82) \_\_\_\_\_

*Fill in the blank or provide a short answer:*

83) The area in the center of the gray matter of the spinal cord that contains cerebrospinal fluid—fluid that continues down the fourth ventricle—is called the \_\_\_\_\_. 83) \_\_\_\_\_

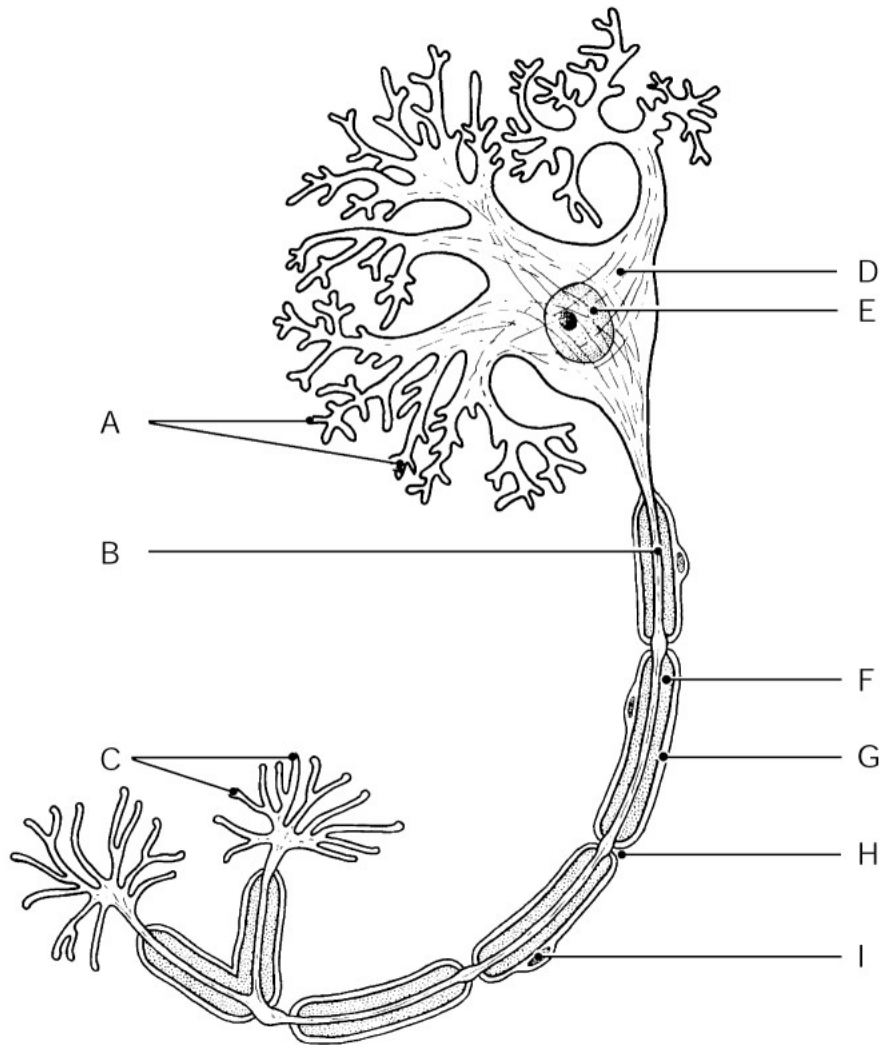

Figure 7.1

Using Figure 7.1, identify the following:

84) The gaps between Schwann cells are indicated by letter \_\_\_\_\_.

84) \_\_\_\_\_

Fill in the blank or provide a short answer:

85) All motor and association neurons are classified structurally as \_\_\_\_\_ neurons.

85) \_\_\_\_\_

86) \_\_\_\_\_ cells form the myelin sheaths around nerve fibers in the PNS.

86) \_\_\_\_\_

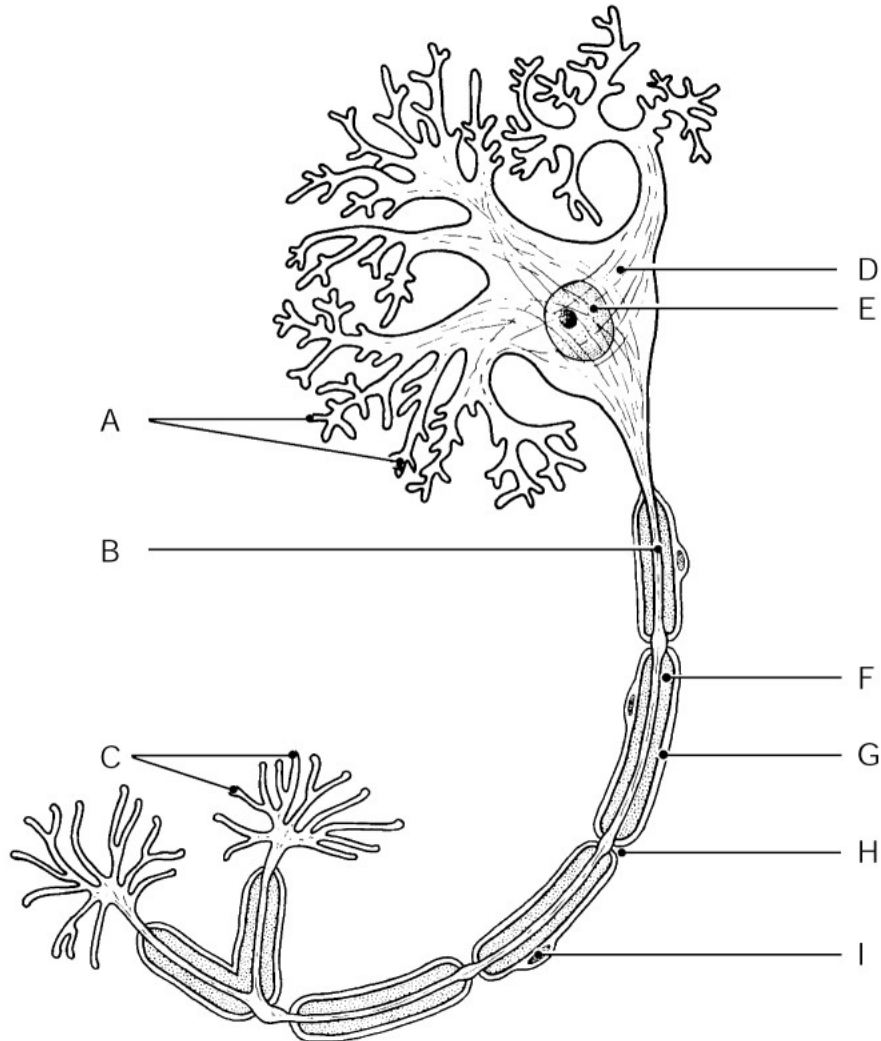

Figure 7.1

Using Figure 7.1, identify the following:

87) The metabolic center of the neuron is indicated by letter \_\_\_\_\_.

87) \_\_\_\_\_

88) The nucleus of the neuron is indicated by letter \_\_\_\_\_.

88) \_\_\_\_\_

Fill in the blank or provide a short answer:

89) The perineurium is a coarse connective wrapping that defines the boundary of a fiber bundle called a(n) \_\_\_\_\_.

89) \_\_\_\_\_

90) The \_\_\_\_\_ is a connective tissue wrapping around fascicles of neuron fibers.

90) \_\_\_\_\_

91) Cerebrospinal fluid is formed from blood by the \_\_\_\_\_.

91) \_\_\_\_\_



92) Each spinal nerve divides into a dorsal and a ventral \_\_\_\_\_. 92) \_\_\_\_\_

*Fill in the blank or provide a short answer:*

93) The brain dysfunction where blood supply to a region (or regions) of the brain is blocked and vital brain tissue dies, as by a blood clot or a ruptured blood vessel, is called \_\_\_\_\_. 93) \_\_\_\_\_

94) Neurons with two processes, an axon and a dendrite, are structurally classified as \_\_\_\_\_ neurons. 94) \_\_\_\_\_

95) The only pair of cranial nerves to extend to the thoracic and abdominal cavities is the \_\_\_\_\_ nerves. 95) \_\_\_\_\_

96) The brain and spinal cord are protected and cushioned by three connective tissue membranes that are collectively called \_\_\_\_\_. 96) \_\_\_\_\_

97) Explain how multiple sclerosis affects nerve functioning. 97) \_\_\_\_\_

98) The \_\_\_\_\_ division of the ANS activates when we are frightened or stressed. 98) \_\_\_\_\_

*Fill in the blank or provide a short answer:*

99) \_\_\_\_\_ disease results from a degeneration of the dopamine-releasing neurons of the substantia nigra. 99) \_\_\_\_\_

100) The primary motor area of the brain allows us to consciously control our \_\_\_\_\_ muscles. 100) \_\_\_\_\_

101) Bundles of nerve fibers (neuron processes) running through the CNS are called \_\_\_\_\_, whereas in the PNS they are called \_\_\_\_\_. 101) \_\_\_\_\_

102) The \_\_\_\_\_ nerve, the largest nerve in the body, splits into the common fibular and tibial nerves. 102) \_\_\_\_\_

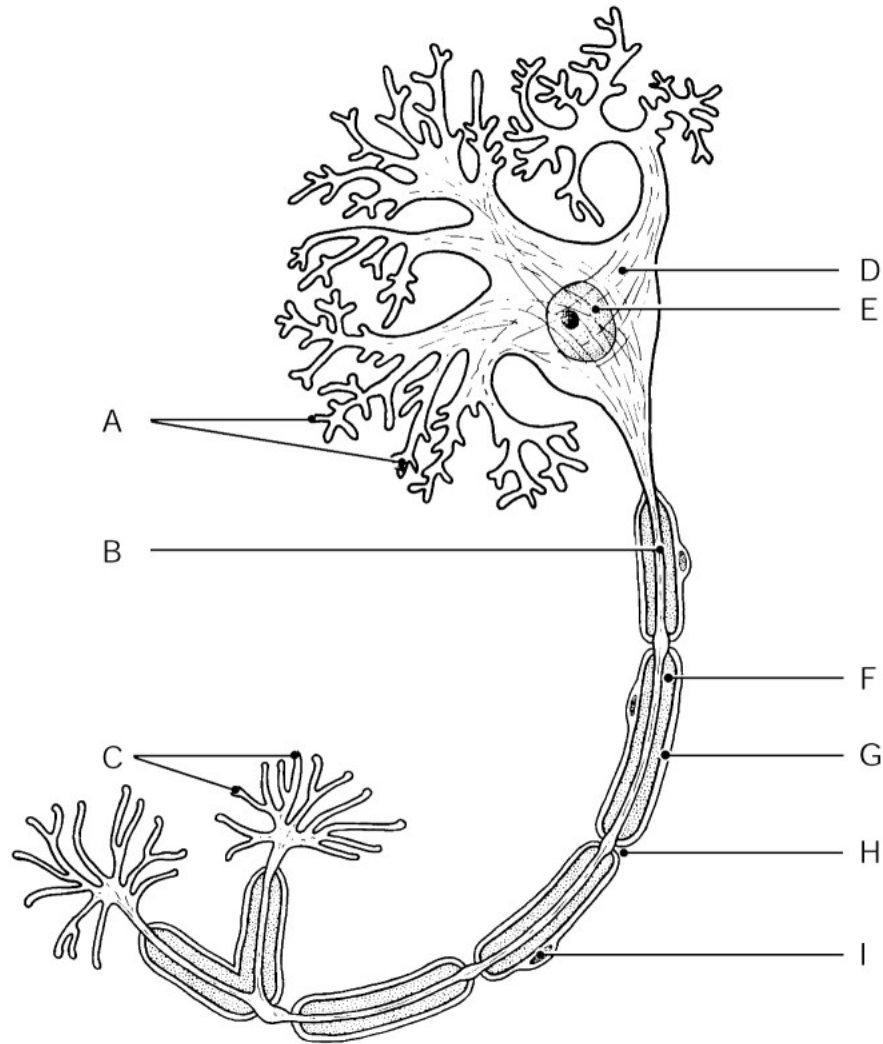

Figure 7.1

Using Figure 7.1, identify the following:

103) The axon terminals are indicated by letter \_\_\_\_\_. 103) \_\_\_\_\_

Fill in the blank or provide a short answer:

104) Sweat glands that produce perspiration when stimulated are innervated only by the \_\_\_\_\_ fibers. 104) \_\_\_\_\_

**TRUE/FALSE. Write 'T' if the statement is true and 'F' if the statement is false.**

105) An afferent sensory neuron carries stimuli from the central nervous system to the effector. 105) \_\_\_\_\_

106) Sympathetic postganglionic fibers release norepinephrine and the preganglionic axon releases acetylcholine. 106) \_\_\_\_\_

107) There is no possibility of damaging the spinal cord below the third lumbar vertebra. 107) \_\_\_\_\_

108) The glossopharyngeal nerve is the only cranial nerve pair that contains sensory fibers. 108) \_\_\_\_\_

109) A polarized neuron has fewer positive ions inside in comparison to the outside of the neuron. 109) \_\_\_\_\_

110) One of the major functions of the pons is to produce releasing factors that control the function of the anterior \_\_\_\_\_

- or 110) \_\_\_\_\_  
pituitary. -
- 111) Myelination of nerve fibers in the central nervous system is the job of the oligodendrocyte. 111) \_\_\_\_\_
- 112) The musculocutaneous nerve is a major nerve of the brachial plexus. 112) \_\_\_\_\_
- 113) Neurons in adults do not undergo mitosis. 113) \_\_\_\_\_
- 114) Sensory neurons carry information away from the CNS. 114) \_\_\_\_\_
- 115) The collection of spinal nerves at the inferior end of the spinal cord is called the cauda equina. 115) \_\_\_\_\_
- 116) Cerebrospinal fluid circulates within the ventricles of the brain and also in the subarachnoid space outside the brain. 116) \_\_\_\_\_
- 117) Part of the diencephalon structure is formed by the hypothalamus. 117) \_\_\_\_\_
- 118) Most body organs are innervated by only the sympathetic division of the nervous system. 118) \_\_\_\_\_
- 119) Reflexes are rapid, predictable, and automatic responses to stimuli. 119) \_\_\_\_\_
- 120) Oligodendrocytes produce myelin sheaths in the PNS. 120) \_\_\_\_\_
- 121) In contrast to the parasympathetic division, the sympathetic division has numerous ganglionic neurons in the gray matter of the spinal cord. 121) \_\_\_\_\_
- 122) Bipolar neurons are rare in adults. 122) \_\_\_\_\_
- 123) There are 31 pairs of cranial nerves and 12 pairs of spinal nerves. 123) \_\_\_\_\_
- 124) The all-or-none phenomenon as applied to nerve conduction states that the whole nerve cell must be stimulated for conduction to take place. 124) \_\_\_\_\_
- 125) Saltatory conduction occurs due to the presence of salt (NaCl) around the neuron. 125) \_\_\_\_\_
- 126) Cranial nerve XI is the accessory nerve that controls tongue movement. 126) \_\_\_\_\_
- 127) The nodes of Ranvier are found at regular intervals only on myelinated, peripheral nerve fibers. 127) \_\_\_\_\_
- 128) Cell bodies of sensory neurons are always located in ganglia lying outside the central nervous system. 128) \_\_\_\_\_
- 129) Difficulty in breathing may reflect damage to respiratory centers located in the cerebellum. 129) \_\_\_\_\_

**MATCHING. Choose the item in column 2 that best matches each item in column 1.**

*Match the following:*

- 130) Motor control of the visceral organs                  A) reticular formation                  130) \_\_\_\_\_

*Match the following:*

- 131) Cranial nerve VII                  A) Facial                  131) \_\_\_\_\_  
B)

Olfactory

Match the following:

132) Somatic motor cortex

A) corticospinal tract

132) \_\_\_\_\_

133) Motor speech area

B) basal nuclei

133) \_\_\_\_\_

C)  
frontal lobe

Match the following:

134) Cranial nerve IX

A) Glossopharyngeal

134) \_\_\_\_\_

Match the following:

135) Auditory area

A) temporal lobe

135) \_\_\_\_\_

B)  
occipital lobe

Match the following:

136) Contains centers that control heart rate, blood pressure, breathing, swallowing, and vomiting

A) medulla oblongata

136) \_\_\_\_\_

Match the following:

137) Fibers emerge from the medulla and run to the throat

A) Vagus

137) \_\_\_\_\_

138) Cranial nerve IV

B) Trigeminal

138) \_\_\_\_\_

139) Promotes digestive activity and regulates heart activity

C) Accessory

139) \_\_\_\_\_

D) Trochlear

E) Hypoglossal

Match the following:

140) Composed of cerebral peduncles and the corpora quadrigemina

A) thalamus

140) \_\_\_\_\_

141) Relay station for sensory impulses passing to the sensory cortex

B) midbrain

141) \_\_\_\_\_

Match the following:

142) Premotor area

A) parietal lobe

142) \_\_\_\_\_

143) Primary sensory cortex

B) frontal lobe

143) \_\_\_\_\_

C)  
interbrain

D) pyramidal tract

*Match the following:*

144) Specific period during which potassium ions diffuse out of the neuron due to a change in membrane permeability

A) polarization

144) \_\_\_\_\_

B)  
repolarization

*Match the following:*

145) Regulates body temperature, water balance, and metabolism

A) hypothalamus

145) \_\_\_\_\_

*Match the following:*

146) Moves eyes laterally

A) Abducens

146) \_\_\_\_\_

B)  
Vestibulocochlear

*Match the following:*

147) Period when the interior of the cell becomes less negative due to an influx of sodium ions

A) action potential

147) \_\_\_\_\_

B)  
repolarization

148)  
Termed a nerve impulse when transmitted

C) depolarization

148) \_\_\_\_\_

*Match the following:*

149) Visual area

A) occipital lobe

149) \_\_\_\_\_

B)  
midbrain

*Match the following:*

150) Controls lens shape and pupil size

A) Optic

150) \_\_\_\_\_

151) Cranial nerve II

B) Oculomotor

151) \_\_\_\_\_

*Match the following:*

152) Gland that hangs from the hypothalamus

A) pituitary gland

152) \_\_\_\_\_

*Match the following:*

153) Period when the neuron is at rest; it has a more negative interior in comparison to the positive exterior

A) graded potential

153) \_\_\_\_\_

B)  
polarization

154)

Local depolarization is also known as  
this term

154) \_\_\_\_\_

**ESSAY. Write your answer in the space provided or on a separate sheet of paper.**

- 155) Compare the sympathetic and parasympathetic branches of the autonomic nervous system with respect to the location of the centers, location of the ganglia, neurotransmitters, and their specific effects.
- 156) List and explain the three general functions of the nervous system
- 157) List the four events that lead to transmission of an impulse across a synapse.
- 158) List and describe the two principal divisions of the peripheral nervous system and their subdivisions.
- 159) List and describe the protective structures found in the CNS.
- 160) Describe the cells that form myelin sheaths in the CNS and PNS.
- 161) List and explain the four major events that take place during the conduction of a nerve impulse beginning with the resting membrane.

- 1) E
- 2) A
- 3) B
- 4) A
- 5) E
- 6) A
- 7) B
- 8) A
- 9) B
- 10) B
- 11) A
- 12) C
- 13) A
- 14) B
- 15) C
- 16) A
- 17) D
- 18) C
- 19) A
- 20) B
- 21) B
- 22) C
- 23) E
- 24) B
- 25) D
- 26) D
- 27) D
- 28) D
- 29) E
- 30) A
- 31) A
- 32) A
- 33) B
- 34) B
- 35) B
- 36) A
- 37) B
- 38) E
- 39) A
- 40) E
- 41) E
- 42) D
- 43) A
- 44) D
- 45) C
- 46) C
- 47) C
- 48) C
- 49) B
- 50) B
- 51) E

- 52) B
- 53) A
- 54) C
- 55) A
- 56) A
- 57) D
- 58) E
- 59) C
- 60) E
- 61) C
- 62) orthostatic hypotension
- 63) somatic
- 64) nodes of Ranvier
- 65) polarized
- 66) hypoglossal; XII
- 67) A
- 68) astrocytes
- 69) corpus callosum
- 70) white
- 71) diencephalon (interbrain)
- 72) contusion
- 73) longitudinal fissure
- 74) Alzheimer's disease
- 75) pituitary
- 76) somatic
- 77) B
- 78) motor
- 79) oculomotor
- 80) involuntary
- 81) phrenic
- 82) hypothalamus
- 83) central canal
- 84) H
- 85) multipolar
- 86) Schwann
- 87) D
- 88) E
- 89) fascicle
- 90) perineurium
- 91) choroid plexuses
- 92) ramus
- 93) cerebrovascular accident (CVA), commonly called a stroke
- 94) bipolar
- 95) vagus
- 96) meninges
- 97) People with multiple sclerosis (MS) experience destruction of their myelin sheaths. As destruction progresses, the electrical current is short-circuited. The person affected with MS may experience visual and speech disturbances and lose muscle control.
- 98) sympathetic
- 99) Parkinson's
- 100) skeletal
- 101) tracts; nerves



- 102) sciatic
- 103) C
- 104) sympathetic
- 105) FALSE
- 106) TRUE
- 107) TRUE
- 108) FALSE
- 109) TRUE
- 110) FALSE
- 111) TRUE
- 112) TRUE
- 113) TRUE
- 114) FALSE
- 115) TRUE
- 116) TRUE
- 117) TRUE
- 118) FALSE
- 119) TRUE
- 120) FALSE
- 121) FALSE
- 122) TRUE
- 123) FALSE
- 124) FALSE
- 125) FALSE
- 126) FALSE
- 127) TRUE
- 128) TRUE
- 129) FALSE
- 130) A
- 131) A
- 132) C
- 133) C
- 134) A
- 135) A
- 136) A
- 137) E
- 138) D
- 139) A
- 140) B
- 141) A
- 142) B
- 143) A
- 144) B
- 145) A
- 146) A
- 147) C
- 148) A
- 149) A
- 150) B
- 151) A
- 152) A
- 153) B

154) A

155) 1. Location of the Centers

Sympathetic Nervous System—centers are located in the gray matter of the spinal cord from T<sub>1</sub> to L<sub>2</sub> (therefore it is also called the thoracolumbar nervous system).

Parasympathetic Nervous System—centers are located in the brain (in nuclei of several of the cranial nerves) and in the sacral region of the spinal cord (S<sub>2</sub> to S<sub>4</sub>).

2. Location of Ganglia

Sympathetic Nervous System—ganglia are located in a sympathetic chain or trunks located just outside the spinal cord on each side. Accordingly, preganglionic neurons have short axons and postganglionic neurons have long axons.

Parasympathetic Nervous System—ganglia are located in terminal ganglia, a short distance from the organs served. Accordingly, preganglionic neurons have long axons and postganglionic neurons have short axons.

3. Neurotransmitters

Sympathetic Nervous System—preganglionic axons are cholinergic fibers (produce acetylcholine) and postganglionic axons are adrenergic fibers (produce norepinephrine).

Parasympathetic Nervous System—both preganglionic and postganglionic axons are cholinergic fibers (produce acetylcholine).

4. General Effects—generally speaking, the sympathetic and parasympathetic branches of the autonomic nervous system are antagonistic: on any one organ, these two branches have opposite and counter-balancing effects.

Sympathetic Nervous System—often referred to as the "fight or flight" nervous system; it is active when in an emergency or a threatening situation.

Parasympathetic Nervous System—often referred to as the "rest and digest" nervous system; it is most active when the body is not threatened in any way and is functioning to conserve body energy and promote normal digestion and elimination.

156) 1. Sensory (input) function—the nervous system uses millions of sensory receptors to monitor changes (stimuli) inside and outside the body; the gathered information is called the sensory function.

2. Integrative function—the nervous system processes and interprets sensory input and makes decisions about what should be done and the magnitude to which it should be done at each moment.

3. Motor (output) function—the process of reaction to stimuli; the body responds by activating muscles that can produce motion or glands that can produce and secrete hormones.

157) 1. The impulse arrives at the synaptic knob of the presynaptic neuron.

2. The synaptic vesicle fuses with the presynaptic neuron membrane and the chemical neurotransmitter is released via exocytosis.

3. The neurotransmitter is released, travels across the synaptic cleft, and binds to receptor sites on the postsynaptic neuron. If sufficient neurotransmitter is released, the entire series of events involved in the conduction of a nerve impulse will occur in the postsynaptic neuron.

4. The electrical changes prompted by neurotransmitter binding are very brief because the neurotransmitter is quickly removed from the synapse either by re-uptake into the axonal terminal or by enzymatic breakdown.

158) 1. Sensory (afferent) division—consists of nerve fibers that convey impulses to the central nervous system from sensory receptors located in various parts of the body (i.e., skin, skeletal muscle, visceral organs). This is further subdivided into:

a. Somatic sensory (afferent) fibers—consist of nerve fibers that convey impulses from the skin, skeletal muscle, and joints to the central nervous system.

b. Visceral sensory (afferent) fibers—consist of nerve fibers that convey impulses from the visceral organs to the central nervous system.

2. Motor (efferent) division—consists of nerve fibers that convey impulses from the central nervous system to effected organs called effectors (i.e., muscles and glands). This is further subdivided into:

a. Somatic (voluntary) nervous system—carries impulses from the central nervous system to effectors (skeletal muscles); allows for conscious control of skeletal muscle.

b. Autonomic (involuntary) nervous system—carries impulses from the central

nervous system, the primary capillary plexus, and the lymphatic systems.

- 159) 1. The brain and spinal cord are protected by a bony skull and a bony vertebral column.
2. There are three layers of membranes (meninges) covering the structures in the CNS.
- a. The outermost dura mater surrounds the brain. This double-layered membrane is a leathery covering.
- b. The middle membrane layer is the arachnoid mater, which has a cobweb appearance.
- c. The pia mater is the innermost layer, which clings to the surface of the brain and spinal cord.
3. Cerebrospinal fluid forms a water cushion that circulates in and around the brain and spinal cord. The CSF protects the CNS from blows and other trauma. Also, remember from a previous chapter that water has a high heat capacity that prevents changes in temperature.
- 160) 1. In the CNS, oligodendrocytes wrap their extensions around nerve fibers producing myelin sheaths. Oligodendrocytes can wrap as many as 60 different nerve fibers at the same time.
2. In the PNS, Schwann cells wrap around the axons of nerve fibers.
- 161) 1. Electrical condition of a resting (polarized) membrane—in a resting membrane, the external face of the membrane is slightly positive; its internal face is slightly negative. The chief extracellular ion is sodium, whereas the chief intracellular ion is potassium. A polarized membrane is relatively impermeable to both ions.
2. Depolarization and generation of an action potential—a stimulus changes the permeability of a "patch" of the membrane, and sodium ions diffuse rapidly into the cell. This changes the polarity of the membrane (the outside becomes more negative). If the stimulus is strong enough, an action potential is initiated.
3. Propagation of an action potential—depolarization of the first membrane patch causes permeability changes in the adjacent membrane and the events described in "2" (above) are repeated. Thus the action potential propagates rapidly along the entire length of the membrane.
4. Repolarization—potassium ions diffuse out of the cell as membrane permeability changes again, restoring the negative charge on the inside of the membrane and the positive charge on the outside surface. Repolarization occurs in the same direction as depolarization. The ionic conditions of the resting state are later restored by the activity of the sodium-potassium pump.

Exam

Name \_\_\_\_\_

**MULTIPLE CHOICE. Choose the one alternative that best completes the statement or answers the question.**

- 1) Which one of the following correctly lists the order of the parts through which light passes as it enters the eye: 1) \_\_\_\_\_
  - A) vitreous humor, lens, aqueous humor, cornea
  - B) lens, aqueous humor, cornea, vitreous humor
  - C) cornea, aqueous humor, lens, vitreous humor
  - D) cornea, lens, aqueous humor, vitreous humor
  - E) aqueous humor, cornea, lens, vitreous humor
  
- 2) Sensorineural deafness occurs when there is damage or degeneration of receptor cells of the: 2) \_\_\_\_\_
  - A) spiral organ of Corti or cochlear nerve
  - B) semicircular canals
  - C) spiral organ of Corti
  - D) round window
  - E) ossicles
  
- 3) The oily secretions that lubricate the eye are produced by the: 3) \_\_\_\_\_
  - A) ceruminous glands
  - B) apocrine glands
  - C) ciliary glands
  - D) lacrimal glands
  - E) tarsal glands
  
- 4) The greatest visual acuity is found at the: 4) \_\_\_\_\_
  - A) lens
  - B) fovea centralis
  - C) ciliary body
  - D) optic disc
  - E) iris
  
- 5) Tarsal glands associated with the edges of the eyelids are considered modified: 5) \_\_\_\_\_
  - A) sweat glands
  - B) sebaceous glands
  - C) ceruminous glands
  - D) apocrine glands
  - E) lacrimal glands
  
- 6) The pigmented portion of the eye that has a rounded opening through which light passes is the: 6) \_\_\_\_\_

A) cornea            B) sclera            C) iris            D) lens            E) retina
  
- 7) The gel-like substance that reinforces the eyeball and prevents it from collapsing inward is the: 7) \_\_\_\_\_
  - A) choroid coat
  - B) canal of Schlemm
  - C) aqueous humor
  - D) vitreous humor
  - E) ciliary body
  
- 8) Inflammation of the conjunctiva involves which of the following: 8) \_\_\_\_\_
  - A) portion of the eye that contains the optic nerve



- 16) The middle coat of the eyeball that contains pigment which prevents light from scattering in the eyeball is the: 16) \_\_\_\_\_  
A) sclera                      B) pupil                      C) retina                      D) choroid                      E) cornea
- 17) Stimulation of sour receptors occurs in response to: 17) \_\_\_\_\_  
A) sugar                      B) salt                      C) beef steak                      D) saccharine                      E) lemons
- 18) Which layer of the eye contains rods and cones: 18) \_\_\_\_\_  
A) iris  
B) retina  
C) sclera  
D) choroid  
E) optic nerve
- 19) Hair cells that function as hearing receptors are located within the: 19) \_\_\_\_\_  
A) auditory tube  
B) oval window  
C) auricle  
D) spiral organ of Corti  
E) ossicles
- 20) Which one of the following is NOT part of the inner ear? 20) \_\_\_\_\_  
A) semicircular canals  
B) ossicles  
C) vestibule  
D) cochlea  
E) membranous labyrinth
- 21) Which one of the following is NOT a primary taste sensation: 21) \_\_\_\_\_  
A) salty                      B) sweet                      C) pungent                      D) sour                      E) bitter
- 22) Sound waves entering the external auditory canal hit the eardrum, also known as the: 22) \_\_\_\_\_  
A) oval window  
B) ossicles  
C) tympanic membrane  
D) pinna  
E) auricle
- 23) The auditory ossicle called the "anvil" is also called the: 23) \_\_\_\_\_  
A) incus  
B) stapes  
C) malleus  
D) bony labyrinth  
E) cochlea
- 24) What structure of the eye focuses light on the retina: 24) \_\_\_\_\_  
A) optic chiasma  
B) lens  
C) choroid  
D) sclera  
E) iris

- 25) The congenital condition of "crossed eyes" is also known as: 25) \_\_\_\_\_  
A) hemianopia  
B) hyperopia  
C) presbyopia  
D) strabismus  
E) myopia
- 26) The portion of the bony labyrinth responsible for static equilibrium is the: 26) \_\_\_\_\_  
A) oval window  
B) ossicles  
C) semicircular canals  
D) vestibule  
E) cochlea
- 27) The inability to see distant objects is termed "nearsighted" or: 27) \_\_\_\_\_  
A) emmetropia  
B) presbyopia  
C) myopia  
D) hyperopia  
E) astigmatism
- 28) An ear infection following an illness such as a cold has passed from the throat through the auditory tube to the: 28) \_\_\_\_\_  
A) middle ear  
B) semicircular canals  
C) inner ear  
D) eardrum  
E) outer ear
- 29) The pathway of vibrations through the ossicles from the tympanic membrane, or eardrum, to the oval window is: 29) \_\_\_\_\_  
A) incus, malleus, stapes  
B) stapes, incus, malleus  
C) malleus, stapes, incus  
D) malleus, incus, stapes  
E) stapes, malleus, incus
- 30) The highly contagious bacterial infection known as "pinkeye" is caused by bacterial or viral irritation of the: 30) \_\_\_\_\_  
A) cornea  
B) conjunctiva  
C) retina  
D) choroid  
E) sclera
- 31) Which one of the following cranial nerves is NOT involved in either taste or smell: 31) \_\_\_\_\_  
A) vestibular (VIII)  
B) glossopharyngeal (IX)  
C) olfactory nerve (I)  
D) facial nerve (VII)  
E) vagus (X)

- 32) The aqueous humor of the eye is reabsorbed into venous blood through the: 32) \_\_\_\_\_  
A) inferior lacrimal canal  
B) pupil  
C) nasolacrimal duct  
D) scleral venous sinus (canal of Schlemm)  
E) ciliary body
- 33) The gland that produces tears in the eye is called the: 33) \_\_\_\_\_  
A) ceruminous gland  
B) ciliary gland  
C) tarsal gland  
D) lacrimal gland  
E) sebaceous gland
- 34) Dynamic equilibrium receptors are found in the: 34) \_\_\_\_\_  
A) oval window  
B) cochlea  
C) semicircular canals  
D) malleus  
E) vestibule
- 35) Which one of the following is NOT true of color blindness: 35) \_\_\_\_\_  
A) lack of red or green receptors is the most common type  
B) it is sex-linked, inherited homeostatic imbalance  
C) it is caused by a defect in genes on the X (female) sex chromosome  
D) it occurs most often in women  
E) it results from lack of cones
- 36) Receptors stimulated by the physical forces that cause movement of fluid or vibration within the body are: 36) \_\_\_\_\_  
A) proprioceptors  
B) thermoreceptors  
C) chemoreceptors  
D) gustatory receptors  
E) mechanoreceptors
- 37) The transparent central anterior portion of the sclera through which light enters the eye is called the: 37) \_\_\_\_\_  
A) cornea            B) choroid            C) pupil            D) iris            E) retina
- 38) Gustatory hairs are to taste as olfactory hairs are to: 38) \_\_\_\_\_  
A) both hearing and dynamic equilibrium  
B) dynamic equilibrium  
C) sight  
D) hearing  
E) smell
- 39) Hearing receptors within the spiral organ of Corti are called: 39) \_\_\_\_\_  
A) cone cells  
B) Corti cells  
C) hair cells  
D) rod cells



E) ceruminous cells

40) The fibrous outermost tunic seen anteriorly as the "white of the eye" is the:

40) \_\_\_\_\_

- A) retina
- B) sclera
- C) choroid
- D) cornea
- E) fovea centralis

**SHORT ANSWER. Write the word or phrase that best completes each statement or answers the question.**

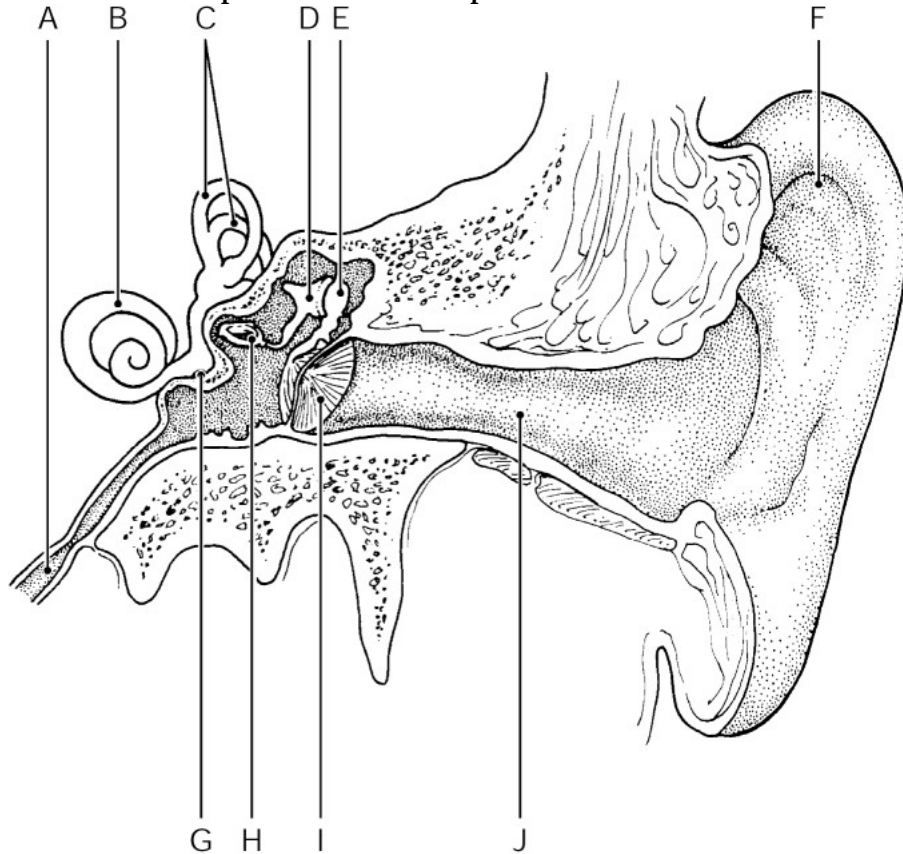

Figure 8.1

Using Figure 8.1, identify the following:

41) The tympanic membrane is indicated by letter \_\_\_\_\_.

41) \_\_\_\_\_

42) A condition in which ear ossicles fuse is known as \_\_\_\_\_.

42) \_\_\_\_\_

43) Bitter receptors on the tongue's taste buds respond to \_\_\_\_\_.

43) \_\_\_\_\_

Fill in the blank or provide a short answer:

44) The eye condition resulting from the inability of the aqueous humor to drain from the eye is called \_\_\_\_\_.

44) \_\_\_\_\_

45) Fibers from the medial side of each eye cross over to the opposite side of the brain at the \_\_\_\_\_.

45) \_\_\_\_\_

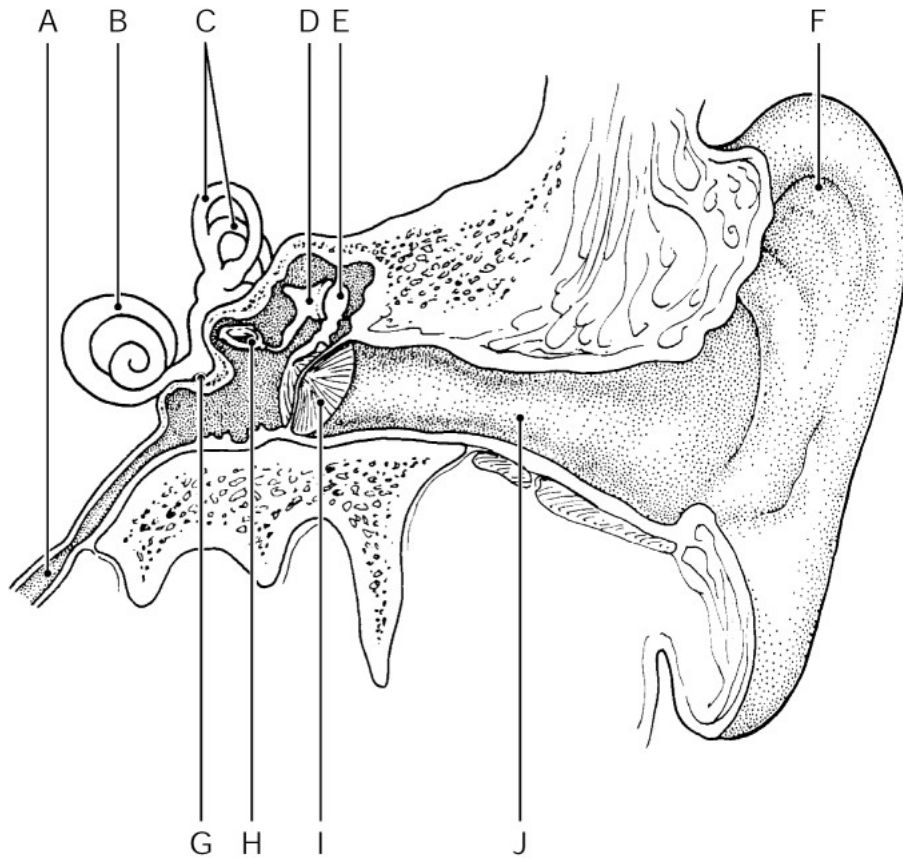

Figure 8.1

Using Figure 8.1, identify the following:

46) The stapes (stirrup) is indicated by letter \_\_\_\_\_.

46) \_\_\_\_\_

Fill in the blank or provide a short answer:

47) Tiny stones made of calcium salts that roll in response to changes in gravitational pull are called \_\_\_\_\_.

47) \_\_\_\_\_

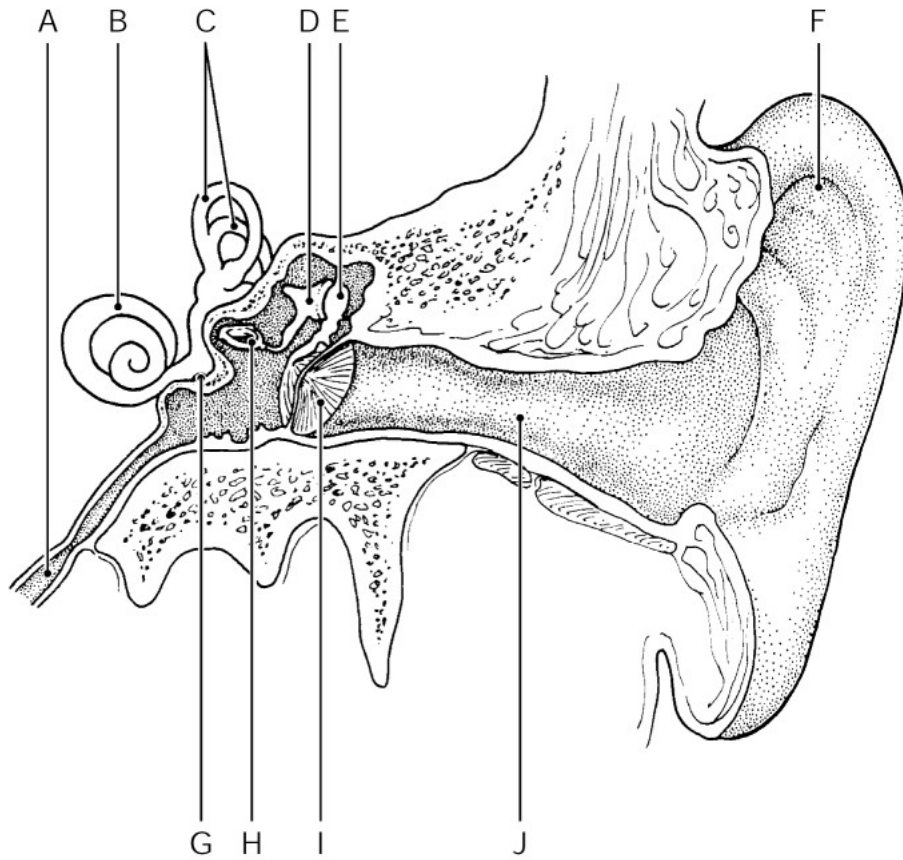

Figure 8.1

Using Figure 8.1, identify the following:

48) The pharyngotympanic (auditory) tube is indicated by letter \_\_\_\_\_.

48) \_\_\_\_\_

Fill in the blank or provide a short answer:

49) Earwax is produced by \_\_\_\_\_.

49) \_\_\_\_\_

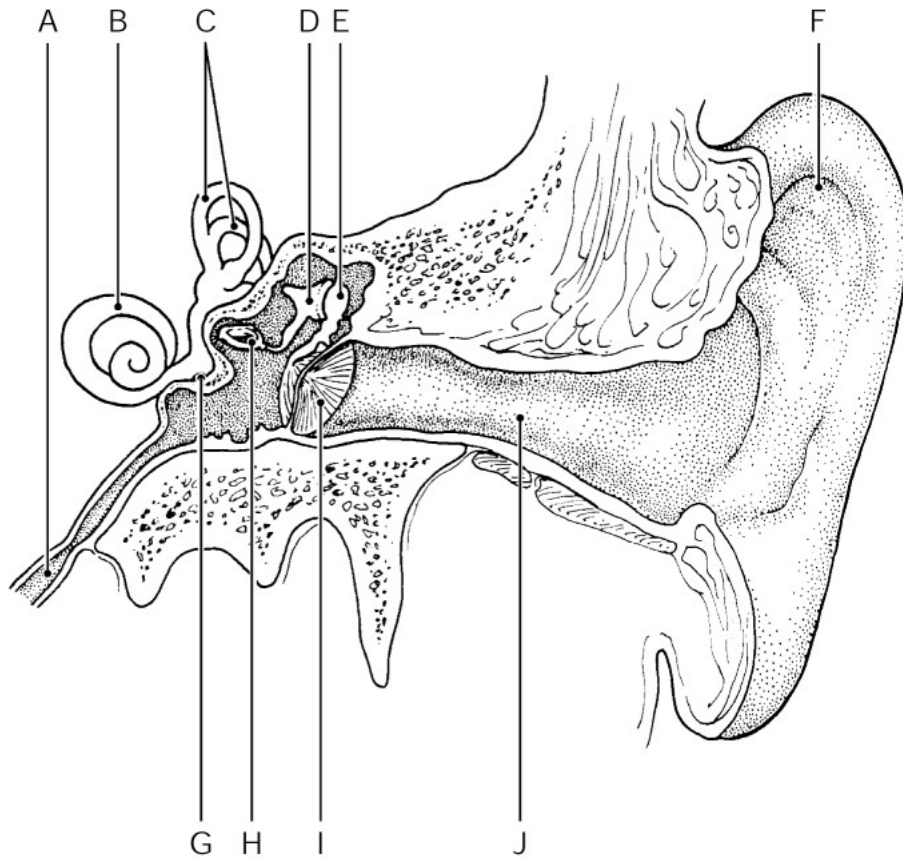

Figure 8.1

Using Figure 8.1, identify the following:

50) The cochlea is indicated by letter \_\_\_\_\_.

50) \_\_\_\_\_

Fill in the blank or provide a short answer:

51) The six muscles attached to the outer surface of the eye that produce gross eye movements and make it possible for the eyes to follow objects are the \_\_\_\_\_.

51) \_\_\_\_\_

52) The area of sharpest visual acuity that normally contains only cones is the \_\_\_\_\_.

52) \_\_\_\_\_

53) The serious inner ear condition that causes nausea, vertigo, and progressive deafness is called \_\_\_\_\_.

53) \_\_\_\_\_

54) The three subdivisions of the bony labyrinth of the internal ear are \_\_\_\_\_, \_\_\_\_\_, and \_\_\_\_\_.

54) \_\_\_\_\_

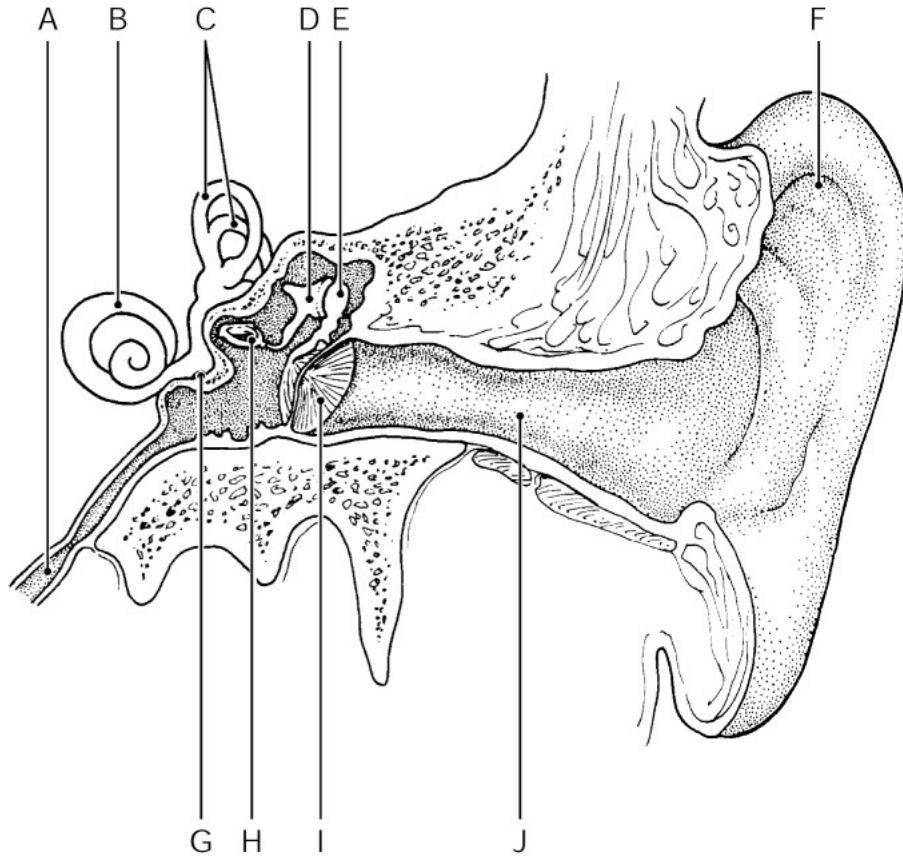

Figure 8.1

Using Figure 8.1, identify the following:

- 55) The semicircular canals are indicated by letter \_\_\_\_\_ . 55) \_\_\_\_\_
- 56) The malleus (hammer) is indicated by letter \_\_\_\_\_ . 56) \_\_\_\_\_

Fill in the blank or provide a short answer:

- 57) The small, peglike projections of the tongue's surface are called \_\_\_\_\_ . 57) \_\_\_\_\_
- 58) Rods and cones are called \_\_\_\_\_ because they respond to light. 58) \_\_\_\_\_
- 59) The upside-down image formed on the retina as a result of the light-bending activity of the lens is the \_\_\_\_\_ . 59) \_\_\_\_\_
- 60) The receptors for taste and smell are classified as \_\_\_\_\_ . 60) \_\_\_\_\_
- 61) The stirrup bone of the internal ear is also known as \_\_\_\_\_ . 61) \_\_\_\_\_
- 62) A division of the cranial nerve, the \_\_\_\_\_ transmits information to the cerebellum about equilibrium. 62) \_\_\_\_\_
- 63) \_\_\_\_\_ glands are located on the lateral end of each eye. 63) \_\_\_\_\_
- 64) Aqueous humor is reabsorbed into venous blood at the sclera-cornea conjunction through the \_\_\_\_\_ . 64) \_\_\_\_\_
- 65) Loss of the same side of the visual field of both eyes from damage to the visual cortex on one side only is called \_\_\_\_\_ . 65) \_\_\_\_\_

- 66) The cochlear nerve transmits impulses to the auditory cortex located in the \_\_\_\_\_. 66) \_\_\_\_\_
- 67) The overlapping of the two visual fields that provides for depth perception (3-D vision) results in \_\_\_\_\_. 67) \_\_\_\_\_
- 68) After age 40 the lens of the eye becomes less elastic; this condition is called \_\_\_\_\_. 68) \_\_\_\_\_

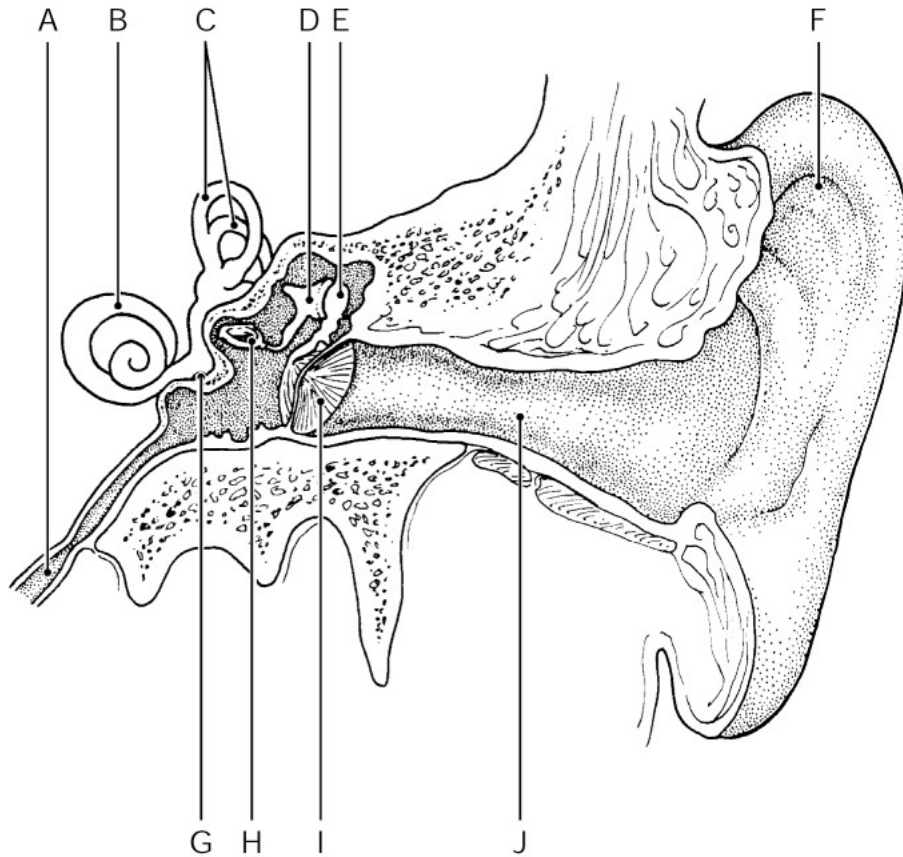

Figure 8.1

Using Figure 8.1, identify the following:

- 69) The auricle (pinna) is indicated by the letter \_\_\_\_\_. 69) \_\_\_\_\_

Fill in the blank or provide a short answer:

- 70) The lens divides the eye into two segments, the \_\_\_\_\_ and the \_\_\_\_\_ segments. 70) \_\_\_\_\_

**TRUE/FALSE. Write 'T' if the statement is true and 'F' if the statement is false.**

- 71) The pinna, also called the auricle, is what most people call the "ear." 71) \_\_\_\_\_
- 72) Deafness is defined as hearing loss ranging from slight to total loss. 72) \_\_\_\_\_
- 73) The conjunctiva is another name for the sclera. 73) \_\_\_\_\_
- 74) The "stirrup" is also referred to as the stapes. 74) \_\_\_\_\_
- 75) Unlike the taste sensation, it is NOT necessary to have the chemicals associated with smells dissolved in body fluids. 75) \_\_\_\_\_

- 76) The pupil is the circular opening in the iris through which light passes. 76) \_\_\_\_\_
- 77) In order to hear sound, vibrations pass from the eardrum to the ossicles, and on to the oval window. 77) \_\_\_\_\_
- 78) Tears are secreted from lacrimal glands located on the medial end of each eye. 78) \_\_\_\_\_
- 79) The normal resting eye is generally "set" for distant vision. 79) \_\_\_\_\_
- 80) The ciliary body is a smooth muscle structure to which the lens is attached. 80) \_\_\_\_\_
- 81) The olfactory receptors are responsible for the sense of taste. 81) \_\_\_\_\_
- 82) An astigmatism results from unequal curvatures of the cornea or lens. 82) \_\_\_\_\_
- 83) There are two varieties of cones; one responds to red light and the other responds to green light. 83) \_\_\_\_\_
- 84) The function of the auditory tube is to transmit sound vibrations. 84) \_\_\_\_\_
- 85) The bony labyrinth of the internal ear consists of the cochlea, vestibule, and the semicircular canals. 85) \_\_\_\_\_
- 86) Gross eye movements are produced by five extrinsic eye muscles attached to the outer surface of each eye. 86) \_\_\_\_\_
- 87) In close vision and bright light, the pupil will dilate. 87) \_\_\_\_\_
- 88) There are five basic taste sensations that correspond to one of the five major types of taste buds. 88) \_\_\_\_\_
- 89) Dynamic equilibrium receptors report the position of the head with respect to the pull of gravity when the body is not moving. 89) \_\_\_\_\_
- 90) Cones enable vision in dim light. 90) \_\_\_\_\_

**MATCHING. Choose the item in column 2 that best matches each item in column 1.**

*Match the following taste sensations:*

- 91) Amino acid glutamate                              A) umami receptors                              91) \_\_\_\_\_
- 92) Hydrogen ions in solution                              A) sour receptors                              92) \_\_\_\_\_

*Match the following ear structures to their appropriate descriptions:*

- 93) Auditory tube                              A) outer ear                              93) \_\_\_\_\_
- 94) Pinna                              B) middle ear                              94) \_\_\_\_\_
- C)  
   links the middle ear and the throat
- D) links the inner ear and the cochlea

*Match the following descriptions to their appropriate eye structure:*

- 95) Blood-rich tunic that contains dark pigment                              A) cornea                              95) \_\_\_\_\_

B) choroid

Match the following taste sensations:

96) Oranges, tomatoes

A) sour receptors

96) \_\_\_\_\_

Match the following descriptions to their appropriate eye structure:

97) Blind spot

A) fovea centralis

97) \_\_\_\_\_

98) Area of greatest visual acuity

B) optic disk

98) \_\_\_\_\_

C)  
optic disc

Match the following taste sensations:

99) Metal ions in solution

A) salty receptors

99) \_\_\_\_\_

Match the following ear structures to their appropriate descriptions:

100) Malleus

A) stirrup

100) \_\_\_\_\_

101) Spiral organ of Corti

B) hammer

101) \_\_\_\_\_

C)  
contains the hair cells

D) snail-like subdivision of the osseous  
labyrinth

Match the following eye disorders with their descriptions:

102) Eyeball is "too short"

A) hyperopia

102) \_\_\_\_\_

Match the following ear structures to their appropriate descriptions:

103) Stapes

A) saddle horn

103) \_\_\_\_\_

B)  
stirrup

104) Semicircular canals

A) contains receptors for dynamic  
equilibrium

104) \_\_\_\_\_

B) contains the cochlea

Match the following descriptions to their appropriate eye structure:

105) Contains millions of photoreceptors

A) fovea centralis

105) \_\_\_\_\_

106) Smooth muscle structures attached to  
the lens

B) retina

106) \_\_\_\_\_

C) ciliary body

D) extrinsic eye muscles

Match the following taste sensations:

107) Sugar, saccharine

A) sweet receptors

107) \_\_\_\_\_



*Match the following descriptions to their appropriate eye structure:*

108) Flexible biconvex crystal-like structure

A) cornea

108) \_\_\_\_

B) lens

*Match the following taste sensations:*

109) Alkaloids

A) bitter receptors

109) \_\_\_\_

*Match the following eye disorders with their descriptions:*

110) Blurry images due to unequal curvatures of the cornea or lens

A) glaucoma

110) \_\_\_\_

B) astigmatism

111) Increased pressure within the eye

C) cataracts

111) \_\_\_\_

*Match the following ear structures to their appropriate descriptions:*

112) Vestibule

A) snail-like subdivision of the osseous labyrinth

112) \_\_\_\_

113) Cochlea

B) contains the ossicles

113) \_\_\_\_

114) Tympanic membrane

C) eardrum

114) \_\_\_\_

D) contains the receptors for static equilibrium

E) contains the receptors for dynamic equilibrium

F) outer ear

*Match the following eye disorders with their descriptions:*

115) Prolonged vitamin A deficiency results in deterioration of the neural retina

A) night blindness

115) \_\_\_\_

*Match the following descriptions to their appropriate eye structure:*

116) Rounded opening through which light passes

A) cornea

116) \_\_\_\_

B) sclera

117) "White of the eye"

C) iris

117) \_\_\_\_

D) pupil

*Match the following eye disorders with their descriptions:*

118) Inflammation of the conjunctiva

A) conjunctivitis

118) \_\_\_\_\_

*Match the following ear structures to their appropriate descriptions:*

119) Incus

A) anvil

119) \_\_\_\_\_

B)  
wedge

*Match the following descriptions to their appropriate eye structure:*

120) Circularly and radially arranged  
pigmented smooth muscle fibers

A) iris

120) \_\_\_\_\_

B) suspensory ligaments

*Match the following eye disorders with their descriptions:*

121) Nearsightedness

A) myopia

121) \_\_\_\_\_

B)  
presbyopia

**ESSAY. Write your answer in the space provided or on a separate sheet of paper.**

122) Describe the path of the optic fibers from the optic nerve to the occipital lobe of the brain.

123) Describe the pathway of light through the eyeball and the process of light refraction.

124) Discuss the age-related disorders presbyopia and presbycusis. Identify the structures each disorder affects.

125) Explain static and dynamic equilibrium and their interrelationships.

126) Explain the meaning of an "odor snapshot" and its relevance to human beings.

127) Explain the mechanism of hearing.

128) Describe the role of the lens in vision. Name and explain the disease caused by the hardening of the lens.

- 1) C
- 2) A
- 3) E
- 4) B
- 5) B
- 6) C
- 7) D
- 8) D
- 9) A
- 10) A
- 11) D
- 12) B
- 13) B
- 14) D
- 15) B
- 16) D
- 17) E
- 18) B
- 19) D
- 20) B
- 21) C
- 22) C
- 23) A
- 24) B
- 25) D
- 26) D
- 27) C
- 28) A
- 29) D
- 30) B
- 31) A
- 32) D
- 33) D
- 34) C
- 35) D
- 36) E
- 37) A
- 38) E
- 39) C
- 40) B
- 41) I
- 42) otosclerosis
- 43) alkaloids
- 44) glaucoma
- 45) optic chiasma
- 46) H
- 47) otoliths
- 48) A
- 49) ceruminous glands
- 50) B
- 51) extrinsic muscles

- 52) fovea centralis
- 53) Meniere's syndrome
- 54) cochlea, vestibule, semicircular canals
- 55) C
- 56) E
- 57) papillae
- 58) photoreceptors
- 59) real image
- 60) chemoreceptors
- 61) stapes
- 62) vestibular nerve
- 63) Lacrimal
- 64) scleral venous sinus or canal of Schlemm
- 65) hemianopia
- 66) temporal lobe
- 67) binocular vision
- 68) presbyopia
- 69) F
- 70) anterior (aqueous); posterior (vitreous)
- 71) TRUE
- 72) TRUE
- 73) FALSE
- 74) TRUE
- 75) FALSE
- 76) TRUE
- 77) TRUE
- 78) FALSE
- 79) TRUE
- 80) TRUE
- 81) FALSE
- 82) TRUE
- 83) FALSE
- 84) FALSE
- 85) TRUE
- 86) FALSE
- 87) FALSE
- 88) TRUE
- 89) FALSE
- 90) FALSE
- 91) B
- 92) A
- 93) C
- 94) A
- 95) B
- 96) A
- 97) C
- 98) A
- 99) A
- 100) B
- 101) A
- 102) A
- 103) D

- 104) A
- 105) B
- 106) C
- 107) A
- 108) B
- 109) A
- 110) B
- 111) A
- 112) D
- 113) A
- 114) C
- 115) A
- 116) D
- 117) B
- 118) A
- 119) A
- 120) A
- 121) A

- 122) Optic fibers from each eye leave the back of the eyeball through the optic nerve. At the optic chiasma, the medial fibers of each eye cross over to the opposite side. The resultant optic tracts contain fibers from the lateral side of the eye on the same side and the medial side of the opposite eye. The optic fibers synapse with neurons in the thalamus, which then continue on to the occipital lobe of the brain.
- 123) Light travels through the cornea, aqueous humor, lens, and vitreous humor before being focused on the retina during normal vision. Refraction by the cornea and humors is constant, whereas the lens changes its shape to be either more or less convex as needed. The greater the convexity, the more light is bent.
- 124) 1. Presbyopia literally means "old vision" and occurs around age 40 and later. As we age, the lens of the eye becomes less elastic. As a result, we have a difficult time focusing on things close to us, such as reading a newspaper, and we essentially become farsighted.
2. Presbycusis is a type of sensorineural deafness that often occurs as we age into our sixties. The deterioration and atrophy of the organ of Corti lead to a loss in the ability to hear high tones and speech sounds. In some cases of presbycusis, the ossicles of the ear fuse leading to difficulty conducting sound in the inner ear.
- 125) Static equilibrium is regulated by the maculae of the vestibule. The maculae report on the position of the head with respect to the pull of gravity when the body is at rest. Each macula is a patch of receptor cells embedded in the otolithic membrane. The otolithic membrane contains otoliths which roll in response to changes in the pull of gravity. This movement causes the hair cells of the membrane to bend, sending impulses along the vestibular nerve to the cerebellum, relating information regarding the position of the head in space. Dynamic equilibrium is regulated by the semicircular canals. The crista ampullaris of the membranous semicircular canal consists of a tuft of hair cells and their gelatinous cap called the cupula. Movement of the head causes the cupula to move in the opposite direction, stimulating the hair cells, which then transmit impulses up the vestibular nerve to the cerebellum. Static and dynamic equilibrium work together to provide information to the cerebellum to help control balance.
- 126) Olfactory receptor cells transmit impulses to the olfactory cortex of the brain for interpretation. An "odor snapshot" is made, which then becomes part of our long-term memory. The olfactory pathways are closely tied to the limbic system, the emotional-visceral part of the brain. Odors elicit strong emotional responses, both positive and negative. The smell of freshly baked cookies, a certain perfume, or a dentist's office all engender their own unique response.
- 127) Sound waves enter the pinna and are transmitted down the external auditory canal until they hit the tympanic membrane and cause it to vibrate. Vibration of the tympanic membrane then causes the ossicles of the middle ear to vibrate, which in turn presses on the oval window of the inner ear. Vibration of the oval window sets the fluids of the inner ear in motion. Movement of the cochlear fluids then stimulate the hair cells of the organ of Corti, which in turn transmit impulses along the cochlear nerve to the auditory cortex in the temporal lobe, where interpretation of sound occurs.

- 128) 1. The lens is the only structure in the eye that can change shape to refract light. The lens becomes more or less convex in order to properly focus light on the retina.
2. Cataracts are caused when the lens becomes increasingly hard and opaque. Vision becomes hazy and blindness can occur in the affected eye.

Exam

Name \_\_\_\_\_

**MULTIPLE CHOICE. Choose the one alternative that best completes the statement or answers the question.**

- 1) Insulin causes: 1) \_\_\_\_\_
  - A) a decrease in the concentration of blood glucose
  - B) an increase in blood pressure
  - C) a decrease in blood pressure
  - D) an increase in the production of glucagon
  - E) an increase in the concentration of blood glucose
  
- 2) The cells in the testes that produce testosterone are called: 2) \_\_\_\_\_
  - A) interstitial cells
  - B) alpha cells
  - C) gonadotropic cells
  - D) beta cells
  - E) pancreatic islet cells
  
- 3) Which one of the following is NOT a sign of diabetes mellitus: 3) \_\_\_\_\_
  - A) polydipsia
  - B) polyuria
  - C) polyphagia
  - D) moon face
  - E) acidosis
  
- 4) Diabetes insipidus is caused by hyposecretion of: 4) \_\_\_\_\_
  - A) glucagon
  - B) antidiuretic hormone (ADH)
  - C) growth hormone
  - D) prolactin (PRL)
  - E) parathyroid hormone (PTH)
  
- 5) Tetany resulting from uncontrolled muscle spasms may indicate a malfunction of the: 5) \_\_\_\_\_
  - A) pineal gland
  - B) adrenal cortex
  - C) thymus
  - D) posterior pituitary
  - E) parathyroid glands
  
- 6) Which one of the following is NOT a symptom of Cushing's syndrome: 6) \_\_\_\_\_
  - A) bronze skin tones
  - B) high blood pressure
  - C) buffalo hump
  - D) moon face
  - E) water retention
  
- 7) Which one of the following hormones exerts its primary effects on the reproductive organs: 7) \_\_\_\_\_
  - A) prolactin
  - B) adrenocorticotrophic hormone
  - C) thyroid-stimulating hormone
  - D) follicle-stimulating hormone
  - E) growth hormone

- 8) Which one of the following is NOT an anterior pituitary hormone: 8) \_\_\_\_\_
- A) prolactin
  - B) antidiuretic hormone
  - C) follicle-stimulating hormone
  - D) adrenocorticotrophic hormone
  - E) luteinizing hormone
- 9) Insulin works as an antagonist to: 9) \_\_\_\_\_
- A) oxytocin
  - B) glucagon
  - C) testosterone
  - D) thyroid hormone
  - E) thymosin
- 10) An enlargement of the thyroid gland resulting from a deficiency of dietary iodine is called: 10) \_\_\_\_\_
- A) goiter
  - B) acromegaly
  - C) cretinism
  - D) myxedema
  - E) exophthalmos
- 11) Which one of the following is NOT a function of oxytocin: 11) \_\_\_\_\_
- A) stimulation of uterine contractions
  - B) stimulation of menstruation
  - C) stimulation of breast milk ejection
  - D) labor induction
  - E) postpartum bleeding control
- 12) Insulin is produced by cells of the pancreatic islets called: 12) \_\_\_\_\_
- A) alpha cells
  - B) delta cells
  - C) gamma cells
  - D) beta cells
  - E) theta cells
- 13) Which one of the following is NOT an action of the catecholamines: 13) \_\_\_\_\_
- A) increased heart rate
  - B) dilation of the small passages of the lungs
  - C) stimulation of the sympathetic nervous system
  - D) decreased blood pressure
  - E) increased blood glucose levels
- 14) Which one of the following is NOT one of the major processes controlled by hormones: 14) \_\_\_\_\_
- A) mobilizing body defenses against stressors
  - B) growth and development
  - C) maintaining electrolyte balance
  - D) body coordination
  - E) regulating cellular metabolism
- 15) Estrogens do all of the following EXCEPT: 15) \_\_\_\_\_
- A) stimulate menstruation



- B) stimulate the development of secondary sex characteristics in females
- C) help maintain pregnancy
- D) stimulate growth of facial hair
- E) prepare the uterus to receive a fertilized egg

- 16) Hypersecretion of growth hormone after long bone growth has ended (as an adult) is called: 16) \_\_\_\_\_
- A) pituitary dwarfism
  - B) acromegaly
  - C) gigantism
  - D) myxedema
  - E) Cushing's disease
- 17) Rising blood levels of aldosterone cause the kidney tubules to: 17) \_\_\_\_\_
- A) reabsorb calcium
  - B) reabsorb sodium
  - C) reabsorb iodine
  - D) reabsorb potassium
  - E) reabsorb hydrogen
- 18) The chemical messengers of the endocrine system are known as: 18) \_\_\_\_\_
- A) stimuli
  - B) neurons
  - C) effectors
  - D) hormones
  - E) target cells
- 19) Alcohol inhibits the secretion of: 19) \_\_\_\_\_
- A) prolactin (PRL)
  - B) antidiuretic hormone (ADH)
  - C) parathyroid hormone (PTH)
  - D) oxytocin
  - E) glucagon
- 20) The hormone that appears to help regulate our sleep-awake cycles is: 20) \_\_\_\_\_
- A) melatonin
  - B) thyroxine
  - C) progesterone
  - D) thymosin
  - E) glucagon
- 21) Which hormone works with estrogen to bring about the menstrual cycle: 21) \_\_\_\_\_
- A) prolactin
  - B) oxytocin
  - C) testosterone
  - D) human chorionic gonadotropin
  - E) progesterone
- 22) Most endocrine organs are prodded into action by other hormones; this type of stimulus is called: 22) \_\_\_\_\_
- A) neural stimulus
  - B) humoral stimulus
  - C) hormonal stimulus

- D) receptor-mediated stimulus
- E) steroid stimulus

- 23) Which one of the following is NOT produced by the adrenal cortex: 23) \_\_\_\_\_
- A) mineralocorticoids
  - B) glucocorticoids
  - C) sex hormones
  - D) aldosterone
  - E) epinephrine
- 24) The element necessary in the diet for proper thyroid function is: 24) \_\_\_\_\_
- A) sodium
  - B) potassium
  - C) iodine
  - D) bromine
  - E) calcium
- 25) Which one of the following is NOT typical of the changes that follow the binding of a hormone to its target cells: 25) \_\_\_\_\_
- A) mitosis is stimulated
  - B) cellular mutations occur
  - C) proteins are synthesized in the cell
  - D) plasma membrane permeability changes
  - E) enzymes are activated or inactivated
- 26) Which of these hormones is released by the adrenal medulla: 26) \_\_\_\_\_
- A) sex hormones
  - B) aldosterone
  - C) glucocorticoids
  - D) epinephrine
  - E) cortisone
- 27) The body's major metabolic hormone is called: 27) \_\_\_\_\_
- A) calcitonin
  - B) growth hormone
  - C) thyroid hormone
  - D) prolactin
  - E) adrenaline
- 28) The hormone that triggers ovulation of an egg from the female ovary is: 28) \_\_\_\_\_
- A) luteinizing hormone
  - B) prolactin
  - C) interstitial cell-stimulating hormone
  - D) progesterone
  - E) follicle-stimulating hormone
- 29) Tropic hormones: 29) \_\_\_\_\_
- A) stimulate the pineal gland to secrete hormones
  - B) stimulate nervous tissue
  - C) stimulate prostaglandins
  - D) stimulate other endocrine glands to secrete hormones
  - E) stimulate the thymus gland to secrete hormones
- 30) The hormone responsible for the maturation of white blood cells known as T lymphocytes is: 30) \_\_\_\_\_
- A) aldosterone
  - B) progesterone

- C) thymosin
- D) melatonin
- E) thyroxine

- 31) The hypothalamus is most closely associated with the: 31) \_\_\_\_\_
- A) thymus gland
  - B) thyroid gland
  - C) pituitary gland
  - D) pineal gland
  - E) pancreas
- 32) Growth hormone: 32) \_\_\_\_\_
- A) results in Cushing's disease if produced in excess
  - B) is produced by the thyroid gland
  - C) promotes growth in long bones and skeletal muscles
  - D) is secreted by the thymus gland
  - E) prevents urine production
- 33) Negative feedback mechanisms regulate: 33) \_\_\_\_\_
- A) steroid hormones only
  - B) very few hormones
  - C) most hormones
  - D) prostaglandin hormones only
  - E) amino acid-based hormones only
- 34) The enzyme produced by the kidneys when blood pressure drops, stimulating a release of aldosterone, is called: 34) \_\_\_\_\_
- A) cortisol
  - B) renin
  - C) angiotensin
  - D) vasopressin
  - E) cortisone
- 35) Prostaglandins are: 35) \_\_\_\_\_
- A) lipid hormones manufactured in cell plasma membranes
  - B) steroid hormones
  - C) amino acid-based hormones
  - D) target organs
  - E) glycerol hormones
- 36) The secondary sex characteristics brought about by testosterone secretion do NOT include: 36) \_\_\_\_\_
- A) development of heavy muscles
  - B) growth of facial hair
  - C) lowering the voice
  - D) development of heavy bones
  - E) development of breasts
- 37) The thyroid gland is located: 37) \_\_\_\_\_
- A) within the parathyroid glands
  - B) below the Adam's apple
  - C) within the mediastinum
  - D) within the pancreas

E) above the kidneys

- 38) Being lipid soluble, steroids can do all the following EXCEPT: 38) \_\_\_\_\_  
A) bind to receptor proteins within the nucleus  
B) catalyze cyclic AMP  
C) enter the nucleus  
D) activate genes to transcribe mRNA for protein synthesis  
E) diffuse through the plasma membranes of target cells
- 39) Glucocorticoids do all of the following EXCEPT: 39) \_\_\_\_\_  
A) decrease edema  
B) suppress inflammation  
C) increase blood glucose levels  
D) help resist long-term stress  
E) regulate salt content of the blood
- 40) Which of these hormones does NOT play a role in reproduction: 40) \_\_\_\_\_  
A) estrogen  
B) luteinizing hormone  
C) testosterone  
D) follicle-stimulating hormone  
E) antidiuretic hormone
- 41) Which one of the following hormones is NOT produced by the anterior lobe of the pituitary gland: 41) \_\_\_\_\_  
A) thyroid-stimulating hormone  
B) oxytocin  
C) growth hormone  
D) prolactin  
E) luteinizing hormone
- 42) Hyposecretion of thyroxine in early childhood leads to: 42) \_\_\_\_\_  
A) exophthalmos  
B) myxedema  
C) cretinism  
D) acromegaly  
E) dwarfism
- 43) The "fight-or-flight" response triggers the release of: 43) \_\_\_\_\_  
A) growth hormone  
B) epinephrine  
C) melatonin  
D) prolactin  
E) ADH
- 44) The pineal gland produces 44) \_\_\_\_\_  
A) insulin            B) cortisol            C) melatonin            D) thymosin            E) estrogen
- 45) Which of these hormones regulate calcium levels in the body: 45) \_\_\_\_\_  
A) T3 and T4  
B) calcitonin and parathyroid hormone  
C) melatonin and glucocorticoids

- D) oxytocin and prolactin
- E) insulin and glucagon

**SHORT ANSWER. Write the word or phrase that best completes each statement or answers the question.**

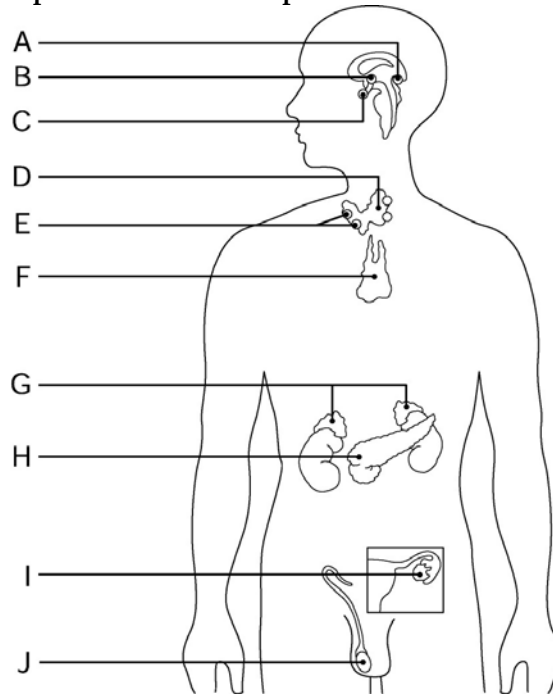

Figure 9.1

Using Figure 9.1, identify the following:

46) The producer of hormones released by the posterior pituitary is indicated by letter \_\_\_\_\_.

46) \_\_\_\_\_

Fill in the blank or provide a short answer:

47) A hormone called \_\_\_\_\_ plays an important role in incubating a special group of white blood cells.

47) \_\_\_\_\_

48) The \_\_\_\_\_ cells of the testes produce testosterone.

48) \_\_\_\_\_

49) A hormone called \_\_\_\_\_ is believed to play an important role in establishing the body's day-night cycle.

49) \_\_\_\_\_

50) Adrenocorticotrophic hormone stimulates the cortex portion of the \_\_\_\_\_ gland.

50) \_\_\_\_\_

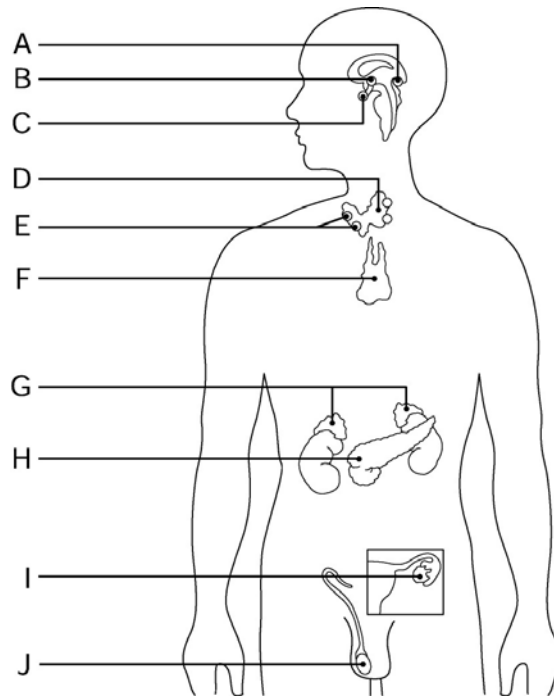

Figure 9.1

Using Figure 9.1, identify the following:

51) The pineal gland is indicated by letter \_\_\_\_\_. 51) \_\_\_\_\_

Fill in the blank or provide a short answer:

52) Calcitonin is made by the \_\_\_\_\_ of the thyroid gland. 52) \_\_\_\_\_

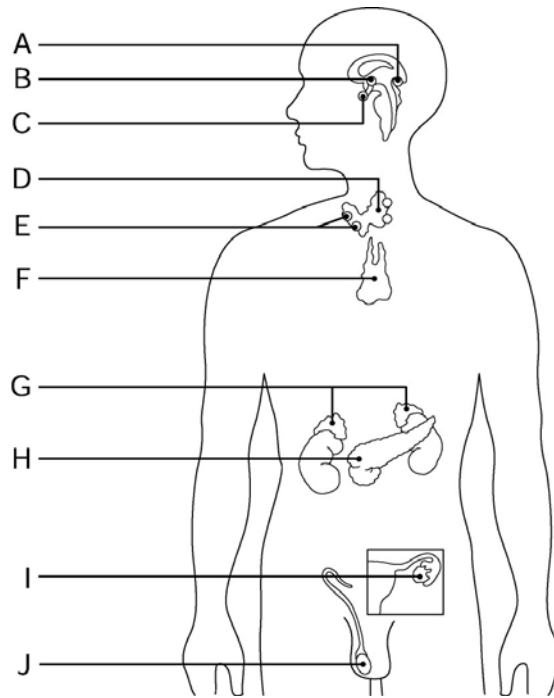

Figure 9.1

Using Figure 9.1, identify the following:

53) The glands that produce steroids and catecholamines are indicated by letter \_\_\_\_\_. 53) \_\_\_\_\_

Fill in the blank or provide a short answer:

54) Cortisone and cortisol and types of \_\_\_\_\_ produced by the middle cortical layer of the adrenal gland. 54) \_\_\_\_\_

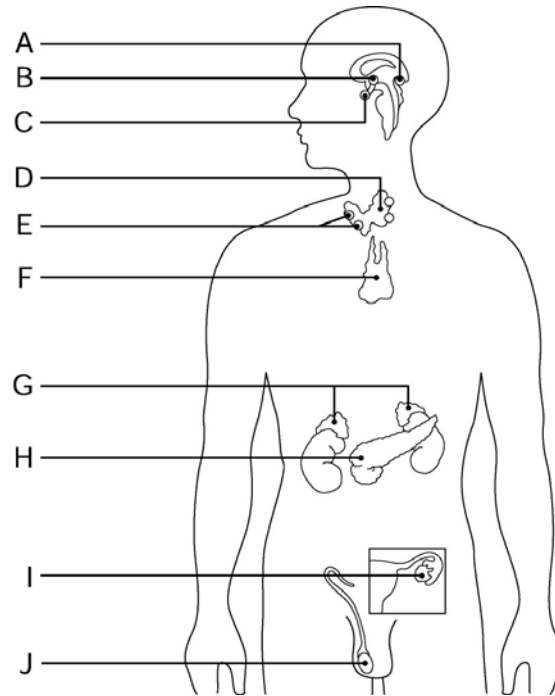

Figure 9.1

Using Figure 9.1, identify the following:

55) The gland that is primarily responsible for body metabolism is indicated by letter \_\_\_\_\_ 55) \_\_\_\_\_

56) The pancreas is indicated by letter \_\_\_\_\_. 56) \_\_\_\_\_

57) The gland that is the major producer of female hormones is indicated by letter \_\_\_\_\_. 57) \_\_\_\_\_

58) The parathyroid glands are indicated by letter \_\_\_\_\_. 58) \_\_\_\_\_

Fill in the blank or provide a short answer:

59) Another name for antidiuretic hormone (ADH) is \_\_\_\_\_. 59) \_\_\_\_\_

60) Another name for epinephrine is \_\_\_\_\_. 60) \_\_\_\_\_

61) Hypersecretion of growth hormone during childhood results in \_\_\_\_\_. 61) \_\_\_\_\_

62) Mineralocorticoids regulate the concentration of \_\_\_\_\_ and \_\_\_\_\_ ions in our blood. 62) \_\_\_\_\_

63) An enlargement of the thyroid gland is called a \_\_\_\_\_. 63) \_\_\_\_\_

64) Insulin and glucagon are both hormones that are produced by \_\_\_\_\_. 64) \_\_\_\_\_

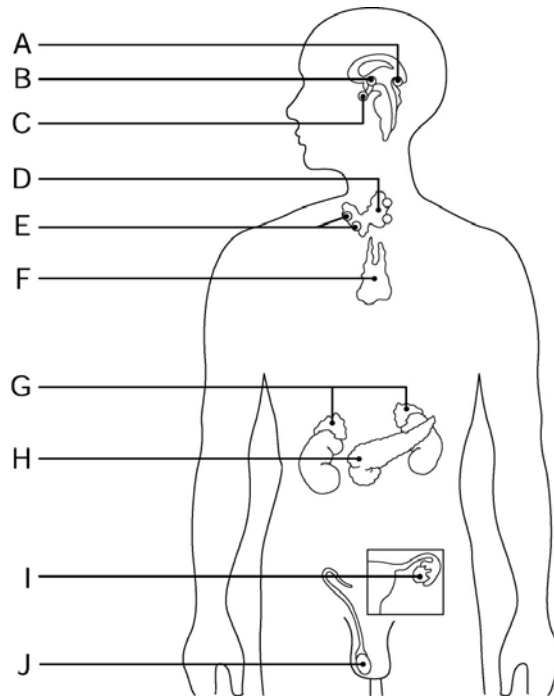

Figure 9.1

Using Figure 9.1, identify the following:

- 65) The thymus gland is indicated by letter \_\_\_\_\_.
- 66) The gland that produces melatonin is indicated by letter \_\_\_\_\_.
- 67) The gland that produces insulin and glucagon is indicated by letter \_\_\_\_\_.

Fill in the blank or provide a short answer:

- 68) The enzyme produced by the kidneys when blood pressure drops, which causes the release of aldosterone, is called \_\_\_\_\_.
- 69) Hypersecretion of glucocorticoids, often caused by a tumor, results in \_\_\_\_\_.
- 70) Home pregnancy tests check for a hormone in the female's urine called \_\_\_\_\_.
- 71) Generalized hyposecretion of all adrenal cortex hormones leads to \_\_\_\_\_.
- 72) Glucagon acts as an antagonist to a hormone called \_\_\_\_\_.
- 73) The posterior pituitary gland releases two hormones called \_\_\_\_\_ and \_\_\_\_\_.



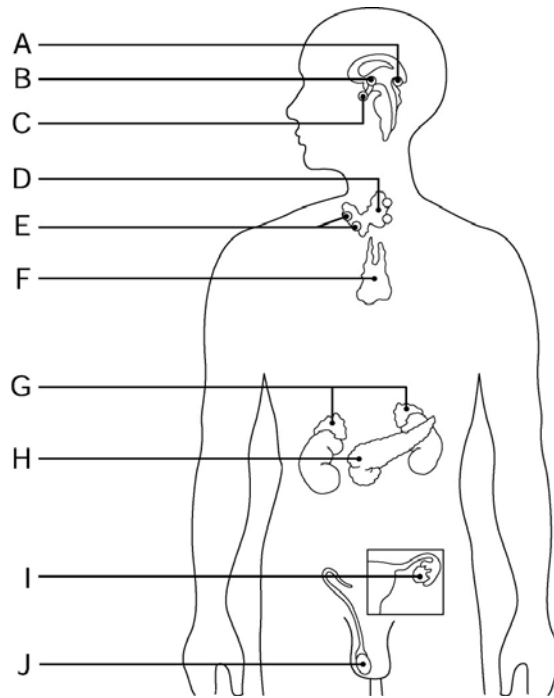

Figure 9.1

Using Figure 9.1, identify the following:

74) The gland that produces thymosin is indicated by letter \_\_\_\_\_. 74) \_\_\_\_\_

Fill in the blank or provide a short answer:

75) Male sex hormones produced by the adrenal cortex are called \_\_\_\_\_. 75) \_\_\_\_\_

76) Anteriorly protruding eyes associated with hyperthyroidism is called \_\_\_\_\_. 76) \_\_\_\_\_

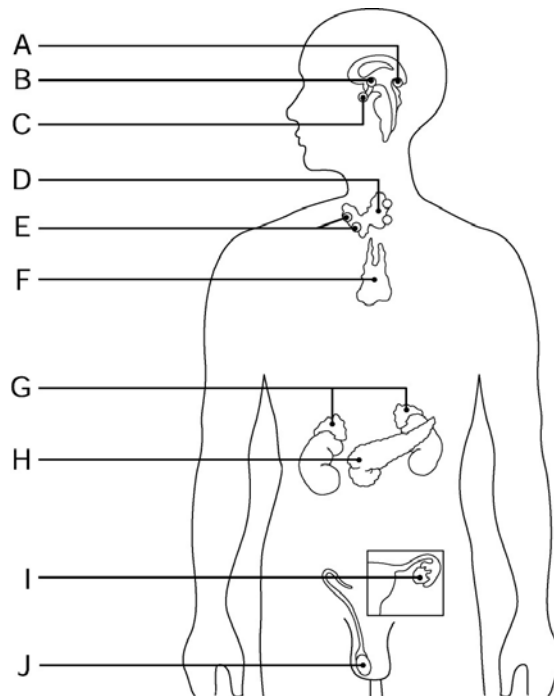

Figure 9.1

Using Figure 9.1, identify the following:

- 77) The gland that produces testosterone is indicated by letter \_\_\_\_\_. 77) \_\_\_\_\_
- 78) The gland that has both glandular and nervous tissue associated with it is indicated by letter \_\_\_\_\_. 78) \_\_\_\_\_
- 79) The glands that act as antagonists to the thyroid gland are indicated by letter \_\_\_\_\_. 79) \_\_\_\_\_

Fill in the blank or provide a short answer:

- 80) Polyuria, polydipsia, and polyphagia are indicative of a disease called \_\_\_\_\_. 80) \_\_\_\_\_

**TRUE/FALSE. Write 'T' if the statement is true and 'F' if the statement is false.**

- 81) Releasing and inhibiting hormones produced by the hypothalamus travel to the anterior pituitary through the blood of the portal circulation. 81) \_\_\_\_\_
- 82) Neurosecretory cells transport oxytocin and antidiuretic hormone to the anterior pituitary gland for storage. 82) \_\_\_\_\_
- 83) The glucocorticoids help the body handle long-term stress primarily by increasing blood glucose levels. 83) \_\_\_\_\_
- 84) The endocrine system is generally faster than the nervous system in coordinating the activities of body cells. 84) \_\_\_\_\_
- 85) The posterior pituitary gland stores the hormones it releases, but does not manufacture them. 85) \_\_\_\_\_
- 86) Melatonin production peaks during the night to help regulate the body's day-night cycle. 86) \_\_\_\_\_
- 87) Most hormones are regulated by negative feedback mechanisms. 87) \_\_\_\_\_
- 88) Glucocorticoids, glucagon, and epinephrine are hyperglycemic hormones. 88) \_\_\_\_\_
- 89) Both male and female sex hormones are produced by the adrenal cortex throughout life in relatively small amounts. 89) \_\_\_\_\_
- 90) The adrenal glands are similar to the pituitary gland in that they have both glandular and neural tissue. 90) \_\_\_\_\_
- 91) Alcohol can suppress the production of antidiuretic hormone. 91) \_\_\_\_\_
- 92) The adrenal medulla and posterior pituitary are both composed of nervous tissue. 92) \_\_\_\_\_
- 93) Parathyroid hormone is the most important regulator of blood calcium concentration. 93) \_\_\_\_\_
- 94) Vasopressin is another name for antidiuretic hormone. 94) \_\_\_\_\_
- 95) The thymus gland is located in the neck wrapped around the trachea. 95) \_\_\_\_\_
- 96) The pituitary gland is found in the brain closely associated with the hypothalamus. 96) \_\_\_\_\_
- 97) Myxedema is the result of hyperthyroidism. 97) \_\_\_\_\_

- 98) The target issue of prolactin is the female breast. 98) \_\_\_\_\_
- 99) Diabetes insipidus is caused by hyposecretion of insulin. 99) \_\_\_\_\_
- 100) Calcitonin is a hormone antagonistic to parathormone in the regulation of blood calcium concentration. 100) \_\_\_\_\_
- 101) Thyroid hormone is actually two iodine-containing hormones called T3 and T4. 101) \_\_\_\_\_
- 102) Hyposecretion of thyroxine in children can result in cretinism. 102) \_\_\_\_\_
- 103) Hypersecretion of growth hormone during childhood leads to pituitary dwarfism. 103) \_\_\_\_\_
- 104) Adrenaline is also known as epinephrine. 104) \_\_\_\_\_
- 105) Hypersecretion of the sex hormones may lead to masculinization in both men and women. 105) \_\_\_\_\_
- 106) Hyposecretion of FSH or LH leads to sterility in both males and females. 106) \_\_\_\_\_
- 107) The pancreas has both endocrine and exocrine functions. 107) \_\_\_\_\_
- 108) Mineralocorticoids help regulate both water and electrolyte balance in body fluids. 108) \_\_\_\_\_
- 109) Exocrine glands are considered ductless glands because they release their hormones into the blood or lymph. 109) \_\_\_\_\_
- 110) The pancreas produces both glucagon and glucocorticoids. 110) \_\_\_\_\_
- 111) The adrenal cortex is made up of neural tissue. 111) \_\_\_\_\_
- 112) The placenta is a temporary organ formed in the uterus of pregnant women. 112) \_\_\_\_\_

**MATCHING. Choose the item in column 2 that best matches each item in column 1.**

*Match the following hormones with their endocrine gland:*

- |                                   |                       |            |
|-----------------------------------|-----------------------|------------|
| 113) Parathormone                 | A) anterior pituitary | 113) _____ |
| 114) Thymosin                     | B) thymus             | 114) _____ |
| 115) Aldosterone                  | C) testes             | 115) _____ |
| 116) Follicle-stimulating hormone | D) parathyroids       | 116) _____ |
|                                   | E) thyroid            |            |
|                                   | F) adrenal medulla    |            |
|                                   | G) adrenal cortex     |            |

*Match the following actions with the appropriate hormone:*

- |                                   |             |            |
|-----------------------------------|-------------|------------|
| 117) Reduces blood glucose levels | A) glucagon | 117) _____ |
|                                   | B)          |            |

insulin

*Match the following hormones with their endocrine gland:*

- |                                   |                                     |            |
|-----------------------------------|-------------------------------------|------------|
| 118) Thyroxine                    | A) posterior pituitary              | 118) _____ |
| 119) Human chorionic gonadotropin | B) thymus                           | 119) _____ |
| 120) Oxytocin                     | C) alpha cells of pancreatic islets | 120) _____ |
| 121) Thyroid-stimulating hormone  | D) placenta                         | 121) _____ |
| 122) Glucagon                     | E) pancreatic islets                | 122) _____ |
| 123) Growth hormone               | F) thyroid                          | 123) _____ |
| 124) Glucocorticoids              | G) adrenal cortex                   | 124) _____ |
| 125) Adrenocorticotrophic hormone | H) anterior pituitary               | 125) _____ |
|                                   | I) uterus                           |            |
|                                   | J) parathyroids                     |            |

*Match the following actions with the appropriate hormone:*

- |  |                         |            |
|--|-------------------------|------------|
| 126) Promotes water retention by the kidneys | A) epinephrine          | 126) _____ |
|  | B) antidiuretic hormone |            |

*Match the following hormones with their endocrine gland:*

- |                          |                                    |            |
|--------------------------|------------------------------------|------------|
| 127) Melatonin           | A) thymus                          | 127) _____ |
| 128) Insulin             | B) adrenal medulla                 | 128) _____ |
| 129) Catecholamines      | C) pineal                          | 129) _____ |
| 130) Luteinizing hormone | D) adrenal cortex                  | 130) _____ |
|                          | E) beta cells of pancreatic islets |            |
|                          | F) corpus luteum                   |            |
|                          | G) anterior pituitary              |            |

*Match the following actions with the appropriate hormone:*

- |  |                        |            |
|--|------------------------|------------|
| 131) Promotes growth of uterine lining | A) progesterone        | 131) _____ |
|  | B) thyroid hormone     |            |
| 132) Raises blood calcium levels       | A) glucocorticoids     | 132) _____ |
|  | B) parathyroid hormone |            |

Match the following hormones with their endocrine gland:

- 133) Antidiuretic hormone
- A) posterior pituitary  
B) adrenal cortex
- 133) \_\_\_\_\_

Match the following actions with the appropriate hormone:

- 134) Stimulates growth of bone and muscles
- A) growth hormone  
B) estrogen
- 134) \_\_\_\_\_

Match the following hormones with their endocrine gland:

- 135) Cortisone
- A) adrenal cortex  
B) adrenal medulla
- 135) \_\_\_\_\_

Match the following actions with the appropriate hormone:

- 136) Stimulates contraction of the uterus
- A) thymosin  
B) oxytocin
- 136) \_\_\_\_\_
- 137) Programs T lymphocytes
- B) oxytocin
- 137) \_\_\_\_\_

Match the following hormones with their endocrine gland:

- 138) Calcitonin
- A) thyroid  
B) parathyroids
- 138) \_\_\_\_\_

Match the following actions with the appropriate hormone:

- 139) Stimulates milk production
- A) prolactin  
B) calcitonin
- 139) \_\_\_\_\_

Match the following hormones with their endocrine gland:

- 140) Prolactin
- A) anterior pituitary  
B) ovaries
- 140) \_\_\_\_\_

**ESSAY. Write your answer in the space provided or on a separate sheet of paper.**

- 141) Explain the negative feedback interaction between calcitonin and parathormone.
- 142) Explain the causes and effects of menopause.
- 143) Explain how insulin and glucagon work as antagonists to one another.
- 144) Explain the pituitary-hypothalamus relationship.
- 145) Describe the three types of stimuli that activate the endocrine organs.
- 146) Jamie is dehydrated from playing a rough game of football on a hot summer afternoon. Explain why beer is not a good choice of beverage considering what you know about antidiuretic hormone.
- 147) Four-year-old Tim is extremely small for his age, and he shows signs of mental retardation. His hair is

thinning dry. His parents have read about cretinism and pituitary dwarfism as possible diagnoses for their son and and his have taken him to the pediatrician for tests to be run. Which diagnosis do you think is correct? Explain why. skin is

148) Compare the effects of hypersecretion and hyposecretion of growth hormone on a child.

149) Explain the two major chemical classifications of hormones.

- 1) A
- 2) A
- 3) D
- 4) B
- 5) E
- 6) A
- 7) D
- 8) B
- 9) B
- 10) A
- 11) B
- 12) D
- 13) D
- 14) D
- 15) D
- 16) C
- 17) B
- 18) D
- 19) B
- 20) A
- 21) E
- 22) C
- 23) E
- 24) C
- 25) B
- 26) D
- 27) C
- 28) A
- 29) D
- 30) C
- 31) C
- 32) C
- 33) C
- 34) B
- 35) A
- 36) E
- 37) B
- 38) B
- 39) E
- 40) E
- 41) B
- 42) C
- 43) B
- 44) C
- 45) B
- 46) B
- 47) thymosin
- 48) interstitial
- 49) melatonin
- 50) adrenal
- 51) A

- 52) parafollicular cells
- 53) G
- 54) glucocorticoids
- 55) D
- 56) H
- 57) I
- 58) E
- 59) vasopressin
- 60) adrenaline
- 61) gigantism
- 62) sodium; potassium
- 63) goiter
- 64) pancreatic islet cells
- 65) F
- 66) A
- 67) H
- 68) renin
- 69) Cushing's syndrome
- 70) human chorionic gonadotropin (hCG)
- 71) Addison's disease
- 72) insulin
- 73) oxytocin; antidiuretic hormone
- 74) F
- 75) androgens
- 76) exophthalmos
- 77) J
- 78) C
- 79) E
- 80) diabetes mellitus
- 81) TRUE
- 82) FALSE
- 83) TRUE
- 84) FALSE
- 85) TRUE
- 86) TRUE
- 87) TRUE
- 88) TRUE
- 89) TRUE
- 90) TRUE
- 91) TRUE
- 92) TRUE
- 93) TRUE
- 94) TRUE
- 95) FALSE
- 96) TRUE
- 97) FALSE
- 98) TRUE
- 99) FALSE
- 100) TRUE
- 101) TRUE
- 102) TRUE
- 103) FALSE



- 104) TRUE
- 105) TRUE
- 106) TRUE
- 107) TRUE
- 108) TRUE
- 109) TRUE
- 110) FALSE
- 111) FALSE
- 112) TRUE
- 113) D
- 114) B
- 115) G
- 116) A
- 117) B
- 118) F
- 119) D
- 120) A
- 121) H
- 122) C
- 123) H
- 124) G
- 125) H
- 126) B
- 127) C
- 128) E
- 129) B
- 130) G
- 131) B
- 132) D
- 133) A
- 134) A
- 135) A
- 136) B
- 137) A
- 138) A
- 139) A
- 140) A
- 141) Calcitonin, released by the thyroid gland, decreases blood calcium levels by causing calcium to be deposited in the bones. Parathormone, released by the parathyroids in response to low blood calcium levels, stimulates bone destruction by osteoclasts, causing release of calcium into the blood. PTH is, therefore, a hypercalcemic hormone, whereas calcitonin is a hypocalcemic hormone. PTH is the most important regulator of calcium ion homeostasis of the blood.
- 142) The onset of menopause, commonly called "change of life," is brought about by decline and atrophy of the ovaries. The decreased production of estrogen and other female hormones results in the inability to bear children, arteriosclerosis, osteoporosis, decreased skin elasticity, and sympathetic nervous system changes. These changes in the sympathetic nervous system bring about what are commonly called "hot flashes." Other symptoms include fatigue, nervousness, and mood changes.
- 143) Hormones that perform opposite actions are called antagonists. Insulin lowers blood glucose levels by increasing the ability of cells to transport glucose across their plasma membranes. Glucagon targets the liver to break down stored glycogen into glucose. The glucose is then released into the bloodstream to increase blood glucose levels.
- 144) Hormones from the anterior pituitary are released in response to releasing and inhibiting hormones produced by the hypothalamus. The hypothalamus releases these hormones into the blood of the portal circulation, which

connect blood supply of the hypothalamus with that of the anterior pituitary. Hormones from the posterior pituitary are secreted in the hypothalamus by hypothalamic neurons. Those hormones are then stored in the posterior pituitary until their release is necessary.

- 145) The most common stimulus is hormonal. In hormonal stimulus, endocrine organs are prodded into action by other hormones, known as tropic hormones. Another type of stimulus is humoral, in which changing blood levels of certain ions and nutrients stimulate hormone release. The third type of stimulus is neural, in which nerve fibers stimulate hormone release.
- 146) Antidiuretic hormone prevents urine production and promotes water retention by the kidneys. However, alcoholic beverages inhibit ADH secretion and result in a large output of urine. Jamie is already dehydrated and alcohol will only further that situation.
- 147) The likely diagnosis is cretinism. Hyposecretion of the thyroid hormone in early childhood leads to cretinism. Cretinism results in dwarfism and mental retardation. Cretinism also causes hair to be scanty and the dry skin. It is unlikely Tim suffers from pituitary dwarfism. Pituitary dwarfism results from hyposecretion of growth hormone in children but does not cause the other symptoms listed.
- 148) Hyposecretion of growth hormone in a child leads to pituitary dwarfism. Body proportions are normal, but the person does not exceed 4 feet in height.  
Hypersecretion of growth hormone in a child leads to gigantism. Although body proportions are normal, the person can reach 8 to 9 feet in height.
- 149) The amino acid-based molecules include proteins, peptides, and amines. The steroid hormones include the sex hormones made by the gonads and the hormones produced by the adrenal cortex.

Exam

Name \_\_\_\_\_

**MULTIPLE CHOICE. Choose the one alternative that best completes the statement or answers the question.**

- 1) Normal whole blood contains \_\_\_\_\_ g of hemoglobin per 100 mL. 1) \_\_\_\_\_  
A) 4-8                      B) 12-18                      C) 15-20                      D) 30-35                      E) 42-48
  
- 2) The matrix of blood is called: 2) \_\_\_\_\_  
A) buffy coat  
B) lymphocytes  
C) formed elements  
D) plasma  
E) erythrocytes
  
- 3) Which of the following is a blood clotting disorder: 3) \_\_\_\_\_  
A) polycythemia  
B) leukopenia  
C) hemophilia  
D) leukocytosis  
E) anemia
  
- 4) The most common type of blood in the U.S. population is: 4) \_\_\_\_\_  
A) A                      B) B                      C) AB                      D) O                      E) AO
  
- 5) Which one of the following is NOT a physical characteristic of blood: 5) \_\_\_\_\_  
A) sticky  
B) sweet tasting  
C) alkaline  
D) heavier than water  
E) opaque
  
- 6) Erythrocytes: 6) \_\_\_\_\_  
A) clot blood  
B) number 4000 to 11,000 per cubic millimeter of blood  
C) can travel by diapedesis  
D) are anucleate  
E) have lobed nuclei and cytoplasmic granules
  
- 7) Excessive erythrocytes result in: 7) \_\_\_\_\_  
A) leukopenia  
B) pernicious anemia  
C) sickle cell anemia  
D) polycythemia  
E) leukocytosis
  
- 8) The type of leukocytes that become macrophages in the tissues are: 8) \_\_\_\_\_  
A) neutrophils  
B) monocytes  
C) eosinophils  
D) lymphocytes  
E) basophils

- 9) In a centrifuged blood sample, the buffy coat between the formed elements and the plasma contains: 9) \_\_\_\_\_
- A) leukocytes only
  - B) leukocytes and erythrocytes
  - C) platelets and erythrocytes
  - D) leukocytes and platelets
  - E) erythrocytes only
- 10) Compatibility testing for agglutination of donor RBCs by the recipients' serum is called: 10) \_\_\_\_\_
- A) cross matching
  - B) blood typing
  - C) hemodialysis
  - D) transfusion reaction
  - E) hemolysis
- 11) Treatment of hemophilia often involves: 11) \_\_\_\_\_
- A) vitamin K supplements and B12 injections
  - B) transfusion of plasma or injections of missing clotting factor
  - C) injections of missing clotting factors and B12 injections
  - D) vitamin K supplements only
  - E) transfusion of plasma and vitamin K supplements
- 12) There are an average of \_\_\_\_\_ WBCs per cubic millimeter of whole blood. 12) \_\_\_\_\_
- A) 100-1000
  - B) 4000-11,000
  - C) 10,000-20,000
  - D) 50,000-100,000
  - E) 1 million-3 million
- 13) Which type of leukocyte contains heparin, an anticoagulant: 13) \_\_\_\_\_
- A) lymphocyte
  - B) neutrophil
  - C) eosinophil
  - D) basophil
  - E) monocyte
- 14) A substance that stimulates the immune system to release antibodies: 14) \_\_\_\_\_
- A) prothrombin activator
  - B) fibrinogen
  - C) antibody
  - D) interleukin
  - E) antigen
- 15) Blood normally clots in approximately: 15) \_\_\_\_\_
- A) 15 minutes
  - B) 3 to 6 minutes
  - C) 5 to 10 minutes
  - D) 1 minute
  - E) 30 minutes
- 16) ABO blood groups are based on the presence of: 16) \_\_\_\_\_
- A) A antigens

- B) B antigens
- C) O antigens
- D) A, B, and O antigens
- E) A and B antigens

- 17) Severe shock occurs with blood loss of: 17) \_\_\_\_\_  
A) over 10 percent  
B) over 20 percent  
C) over 30 percent  
D) over 50 percent  
E) over 5 percent
- 18) The universal recipient has blood type: 18) \_\_\_\_\_  
A) A                      B) B                      C) AB                      D) ABO                      E) O
- 19) Which blood type(s) can a person with blood type O receive: 19) \_\_\_\_\_  
A) blood type A  
B) blood types A, B, AB, or O  
C) blood type B  
D) blood type O  
E) blood type AB
- 20) Megakaryocytes pinch off anucleate fragments called: 20) \_\_\_\_\_  
A) neutrophils  
B) erythrocytes  
C) granulocytes  
D) agranulocytes  
E) platelets
- 21) The most numerous white blood cells are the: 21) \_\_\_\_\_  
A) eosinophils  
B) basophils  
C) monocytes  
D) lymphocytes  
E) neutrophils
- 22) The ion essential for blood clotting is: 22) \_\_\_\_\_  
A) potassium              B) iodine              C) sodium              D) calcium              E) hydrogen
- 23) Which of the following is not a type of red blood cell disorder? 23) \_\_\_\_\_  
A) pernicious anemia  
B) leukemia  
C) aplastic anemia  
D) sickle cell anemia  
E) polycythemia
- 24) A clot that breaks away from a vessel wall and circulates freely within the bloodstream is called a(n): 24) \_\_\_\_\_  
A) embolus  
B) thromboplastin  
C) thrombus  
D) fibrin

E) clotting cascade

- 25) The organ largely responsible for the synthesis of clotting factors is the: 25) \_\_\_\_\_  
A) pancreas      B) kidneys      C) spleen      D) liver      E) thyroid
- 26) Which one of the following does NOT describe blood plasma: 26) \_\_\_\_\_  
A) it is the color of red wine  
B) it contains plasma proteins  
C) it contains metal ions (salts)  
D) it contains hormones  
E) its pH is 7.35 to 7.45
- 27) Which one of the following groups consist of granulocytes: 27) \_\_\_\_\_  
A) basophils and eosinophils  
B) neutrophils, lymphocytes, and eosinophils  
C) lymphocytes and monocytes  
D) neutrophils, eosinophils, and basophils  
E) eosinophils and monocytes
- 28) Bleeding disorders often result from a lack of which one of the following vitamins: 28) \_\_\_\_\_  
A) vitamin B12  
B) vitamin A  
C) vitamin C  
D) vitamin K  
E) vitamin D
- 29) Which chemical is released to bring about vasoconstriction during the vascular spasm phase of hemostasis: 29) \_\_\_\_\_  
A) thrombopoietin  
B) interleukin  
C) erythropoietin  
D) serotonin  
E) renin
- 30) The type of leukocytes that would increase rapidly during allergy attacks and infections of parasitic worms are: 30) \_\_\_\_\_  
A) neutrophils  
B) lymphocytes  
C) monocytes  
D) basophils  
E) eosinophils
- 31) The process whereby the binding of antibodies to antigens causes RBCs to clump is called: 31) \_\_\_\_\_  
A) hemostasis  
B) clotting cascade  
C) hemolysis  
D) coagulation  
E) agglutination
- 32) Platelets are fragments of multinucleate cells called: 32) \_\_\_\_\_  
A) eosinophils  
B) megakaryocytes

- C) macrophages
- D) basophils
- E) erythrocytes

- 33) Blood cell formation is called \_\_\_\_\_ and occurs in red bone marrow. 33) \_\_\_\_\_
- A) hemolysis
  - B) agglutination
  - C) hematopoiesis
  - D) coagulation
  - E) hemostasis
- 34) The average functional lifespan of an RBC is: 34) \_\_\_\_\_
- A) the body's lifetime
  - B) 50-75 days
  - C) 100-120 days
  - D) one year
  - E) 20-30 days
- 35) Which of these blood types carries no antigens: 35) \_\_\_\_\_
- A) blood types A, B, and AB
  - B) blood type A
  - C) blood type O
  - D) blood type B
  - E) blood type AB
- 36) Which antigen(s) does type AB blood contain: 36) \_\_\_\_\_
- A) sometimes A antigens, other times B antigens
  - B) B antigen
  - C) A antigen
  - D) A and B antigens
  - E) no antigens
- 37) Anemias appearing in old age result from all of the following EXCEPT: 37) \_\_\_\_\_
- A) drug therapy
  - B) leukemia
  - C) erythrocyte mutations
  - D) nutritional deficiencies
  - E) vitamin deficiencies
- 38) A \_\_\_\_\_ clot is formed during the process of hemostasis. 38) \_\_\_\_\_
- A) fibrinogen
  - B) fibrin
  - C) prothrombin
  - D) thromboplastin
  - E) thrombin
- 39) The hormone that regulates the rate of erythrocyte production is called: 39) \_\_\_\_\_
- A) renin
  - B) vasopressin
  - C) erythropoietin
  - D) thrombopoietin
  - E) leukopoietin

- 40) The immune serum used to prevent maternal sensitization to Rh antigens is: 40) \_\_\_\_\_  
A) interleukin  
B) RhoGAM  
C) agglutinin  
D) serotonin  
E) HepBIg
- 41) Blood cell formation in adults occurs in all of the following EXCEPT the: 41) \_\_\_\_\_  
A) flat bones of the pelvis  
B) shaft of the femur  
C) proximal epiphyses of the humerus and femur  
D) flat bones of the skull  
E) the epiphyseal plates
- 42) Which one of the following is NOT true of WBCs: 42) \_\_\_\_\_  
A) they use diapedesis to move in and out of blood vessels  
B) they initiate the clotting process  
C) they locate areas of tissue damage through chemotaxis  
D) they move by ameboid motion  
E) they account for less than 1 percent of total blood volume
- 43) An immature RBC is called a: 43) \_\_\_\_\_  
A) granulocyte  
B) hemocytoblast  
C) reticulocyte  
D) agranulocyte  
E) megakaryocyte
- 44) Prothrombin activator converts prothrombin to: 44) \_\_\_\_\_  
A) prothrombin activator  
B) thrombin  
C) fibrin activator  
D) serotonin  
E) fibrinogen
- 45) The series of reactions that stop blood flow following a cut is called: 45) \_\_\_\_\_  
A) homeostasis  
B) hemostasis  
C) coagulation  
D) agglutination  
E) erythropoiesis
- 46) Which one of the following represents the proper sequence of hemostasis: 46) \_\_\_\_\_  
A) vascular spasm, coagulation, platelet plug formation  
B) platelet plug formation, coagulation, vascular spasm  
C) coagulation, platelet plug formation, vascular spasm  
D) vascular spasm, platelet plug formation, coagulation  
E) coagulation, vascular spasm, platelet plug formation
- 47) Which one of the following formed elements is the most abundant: 47) \_\_\_\_\_  
A) platelets



- B) basophils
- C) erythrocytes
- D) eosinophils
- E) lymphocytes

**SHORT ANSWER. Write the word or phrase that best completes each statement or answers the question.**

*Fill in the blank or provide a short answer:*

- 48) The volume of erythrocytes within a given volume of whole blood, expressed as a percentage, is \_\_\_\_\_ 48) \_\_\_\_\_
- 49) The iron-containing protein found in RBCs that transports the majority of oxygen carried in the blood is \_\_\_\_\_ 49) \_\_\_\_\_
- 50) The condition in which fetal RBCs are destroyed faster than the infant liver can rid the body of the breakdown products of hemoglobin is called \_\_\_\_\_ 50) \_\_\_\_\_

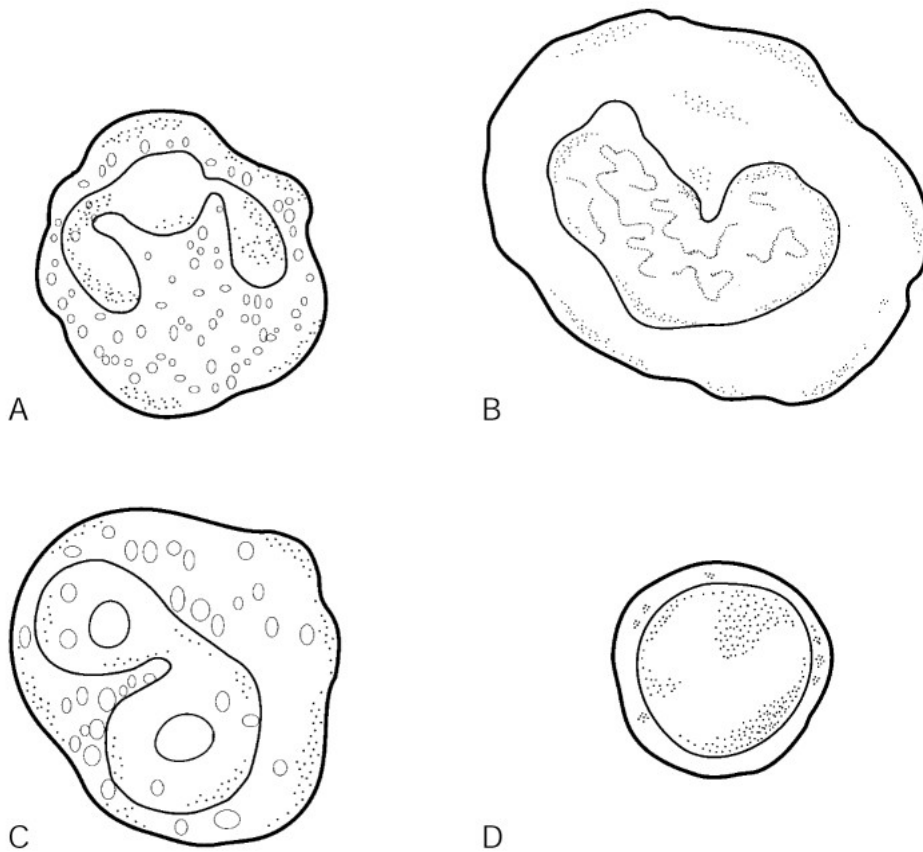

Figure 10.1

*Using Figure 10.1, identify the following:*

- 51) The lymphocyte is indicated by letter \_\_\_\_\_ 51) \_\_\_\_\_

*Fill in the blank or provide a short answer:*

- 52) The movement of WBCs to areas of inflammation in response to chemical mediators is called \_\_\_\_\_ 52) \_\_\_\_\_
- 53) The rarest blood type in the United States is type \_\_\_\_\_ 53) \_\_\_\_\_
- 54) An abnormal elevation of WBCs above the normal count of  $11,000 \text{ cells/mm}^3$  is called \_\_\_\_\_ 54) \_\_\_\_\_

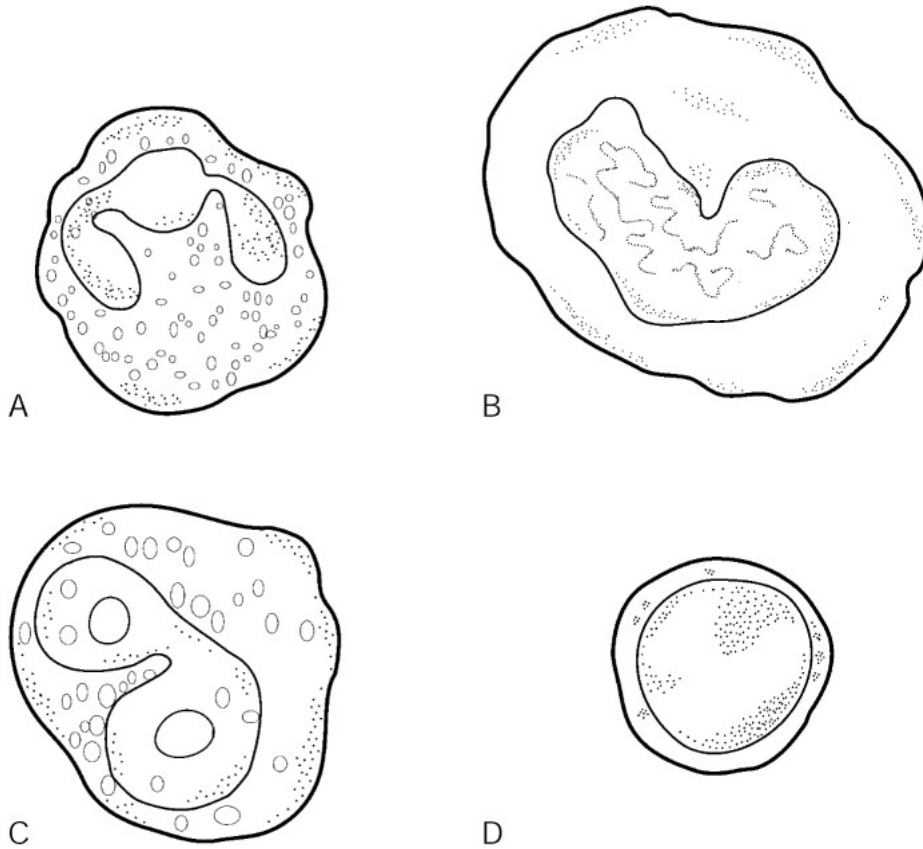

Figure 10.1

Using Figure 10.1, identify the following:

55) The neutrophil is indicated by letter \_\_\_\_\_. 55) \_\_\_\_\_

Fill in the blank or provide a short answer:

56) White blood cells are also called \_\_\_\_\_. 56) \_\_\_\_\_

57) The plasma protein that contributes to the osmotic pressure of blood is \_\_\_\_\_. 57) \_\_\_\_\_

58) The process by which bleeding is stopped is called \_\_\_\_\_. 58) \_\_\_\_\_

59) Blood type A carries the \_\_\_\_\_ antigen. 59) \_\_\_\_\_

60) A decrease in the blood's ability to transport oxygen is called \_\_\_\_\_. 60) \_\_\_\_\_

61) The process by which WBCs are able to easily slip in and out of blood vessels is called \_\_\_\_\_. 61) \_\_\_\_\_

62) If you carry the Rh antigen, you are referred to as Rh \_\_\_\_\_. 62) \_\_\_\_\_

63) A thrombus that has broken away from a vessel wall and is freely floating in the bloodstream is called an \_\_\_\_\_. 63) \_\_\_\_\_

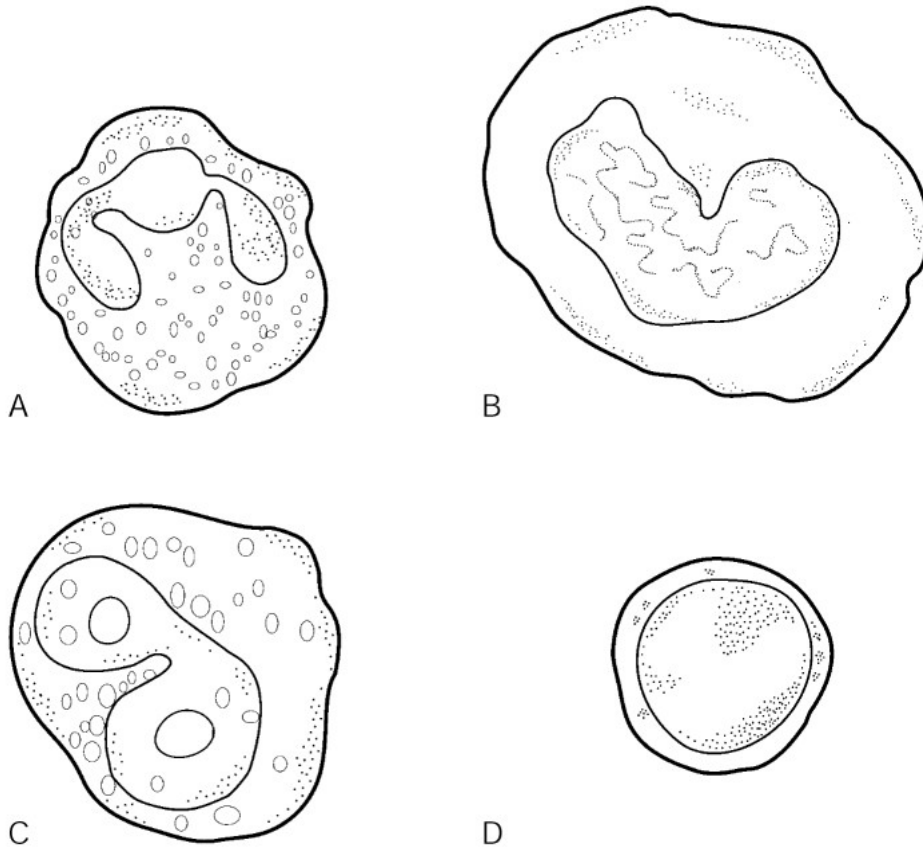

Figure 10.1

Using Figure 10.1, identify the following:

64) The most common type of leukocyte is indicated by letter \_\_\_\_\_.

64) \_\_\_\_\_

Fill in the blank or provide a short answer:

65) Hereditary bleeding disorders that result from lack of clotting factors are referred to as \_\_\_\_\_.

65) \_\_\_\_\_

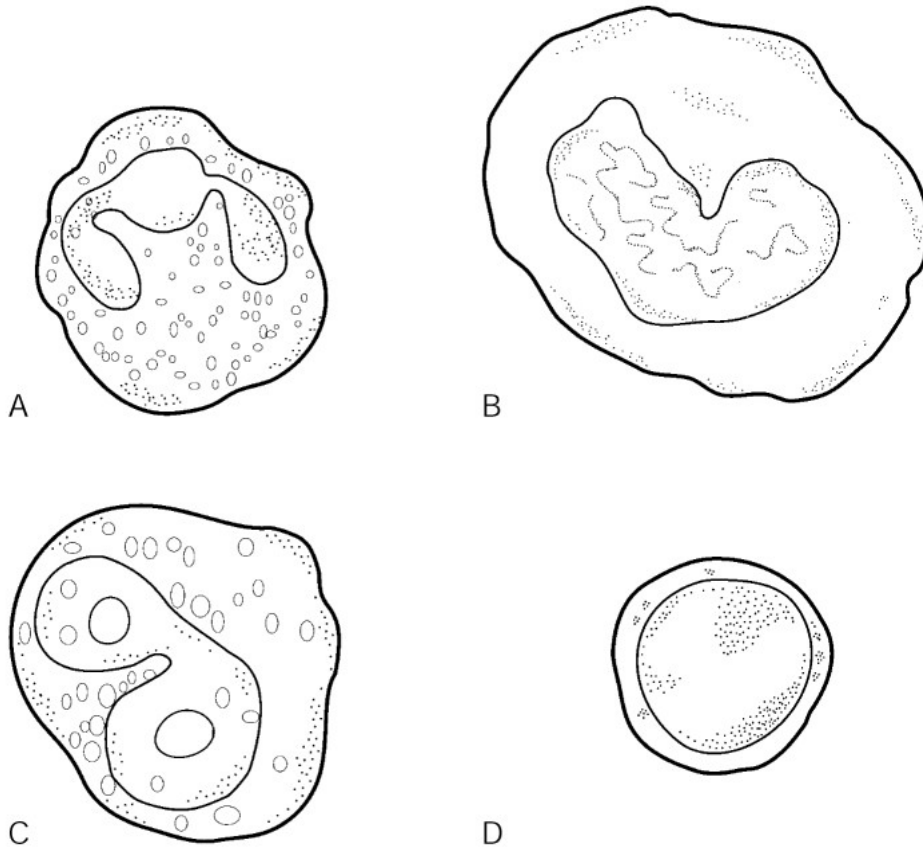

Figure 10.1

Using Figure 10.1, identify the following:

66) The eosinophil is indicated by letter \_\_\_\_\_.

66) \_\_\_\_\_

Fill in the blank or provide a short answer:

67) An insufficiency of circulating platelets is called \_\_\_\_\_.

67) \_\_\_\_\_

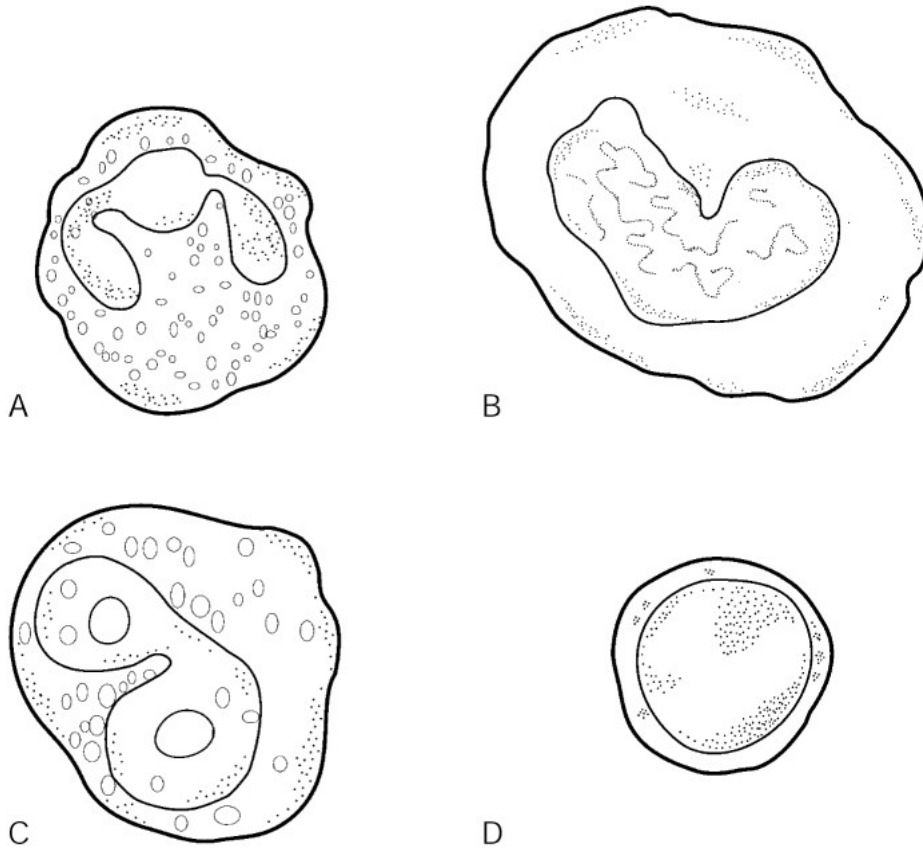

Figure 10.1

Using Figure 10.1, identify the following:

68) The monocyte is indicated by letter \_\_\_\_\_.

68) \_\_\_\_\_

Fill in the blank or provide a short answer:

69) The red blood cell disorder caused by life at a high altitude is called \_\_\_\_\_.

69) \_\_\_\_\_

70) Substances that the body recognizes as foreign are called \_\_\_\_\_.

70) \_\_\_\_\_

71) The blood type referred to as the universal donor is called type \_\_\_\_\_.

71) \_\_\_\_\_

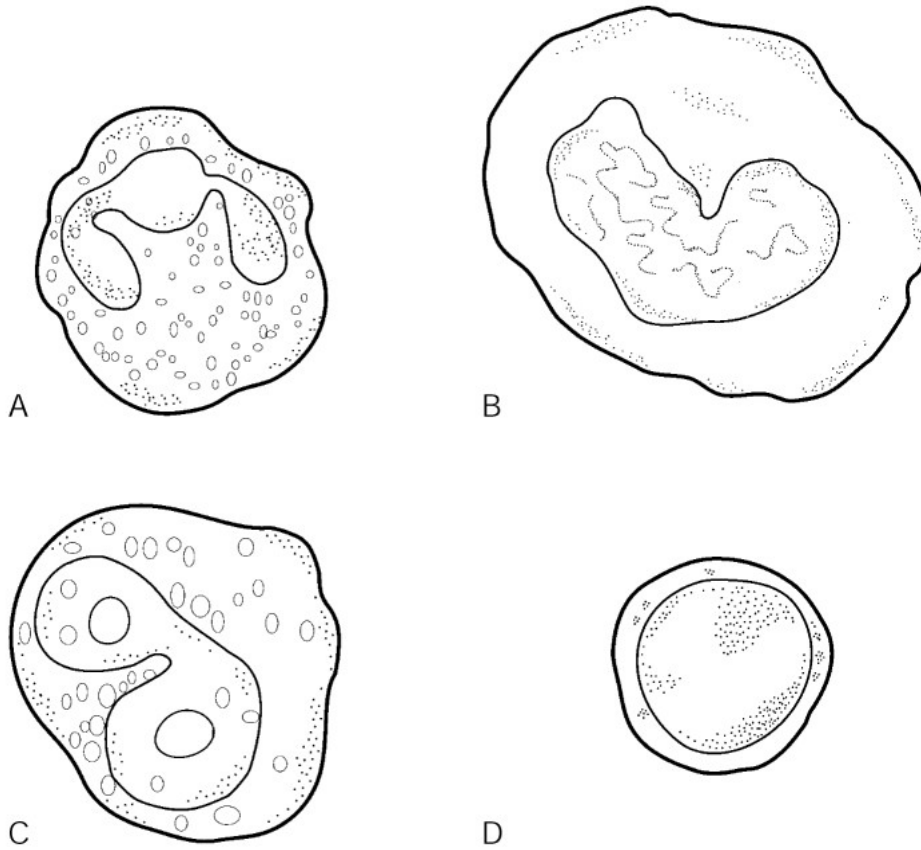

Figure 10.1

Using Figure 10.1, identify the following:

72) The type of leukocyte that fights allergies and parasitic worms is indicated by letter \_\_\_\_\_ 72) \_\_\_\_\_

Fill in the blank or provide a short answer:

73) A person with type B blood can receive blood from blood type(s) \_\_\_\_\_ 73) \_\_\_\_\_

74) The condition in which maternal antibodies cross the placenta and destroy the baby's RBCs is called \_\_\_\_\_ 74) \_\_\_\_\_

75) The anucleate cells that function to transport oxygen to the body's cells are called \_\_\_\_\_ 75) \_\_\_\_\_

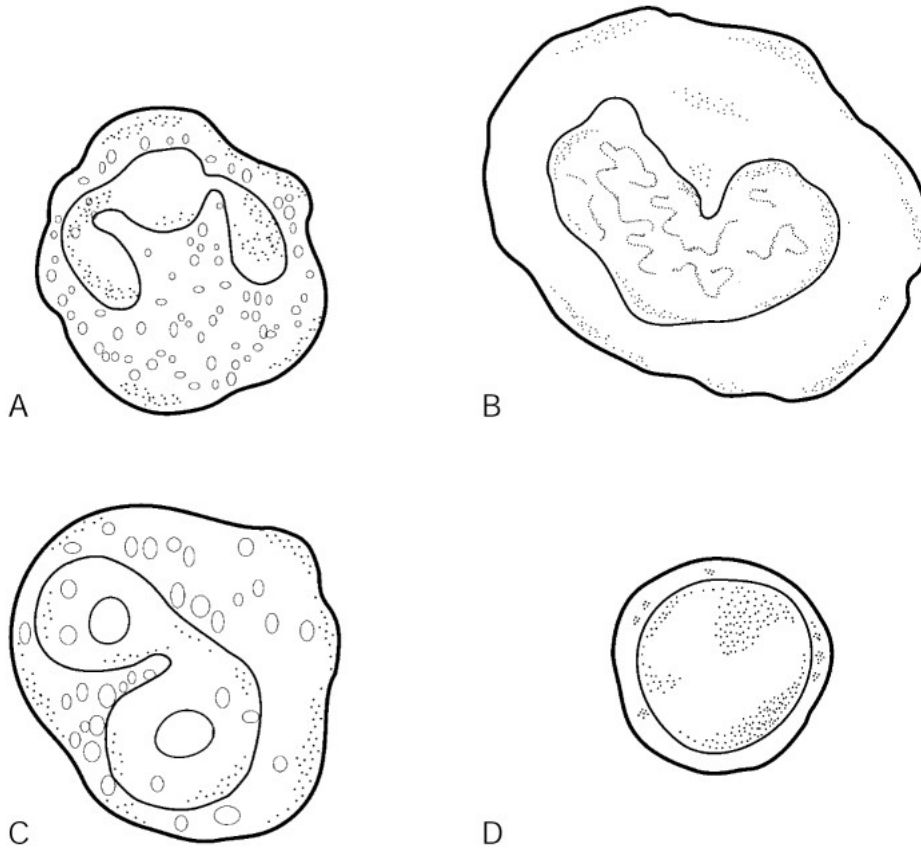

Figure 10.1

Using Figure 10.1, identify the following:

76) The granulocytes are indicated by letters \_\_\_\_\_ and \_\_\_\_\_. 76) \_\_\_\_\_

Fill in the blank or provide a short answer:

77) The process of blood cell formation within the red marrow of bones is called \_\_\_\_\_. 77) \_\_\_\_\_

**TRUE/FALSE. Write 'T' if the statement is true and 'F' if the statement is false.**

78) Leukocytes are more numerous in blood than erythrocytes. 78) \_\_\_\_\_

79) An abnormally low WBC count is called leukopenia. 79) \_\_\_\_\_

80) A phlebotomist collects and processes blood samples for laboratory analysis. 80) \_\_\_\_\_

81) Basophils are the most numerous type of leukocyte. 81) \_\_\_\_\_

82) The temperature of blood is slightly lower than body temperature. 82) \_\_\_\_\_

83) Erythropoietin is released to stimulate platelet production in response to inadequate amounts of oxygen in the blood. 83) \_\_\_\_\_

84) Blood plasma is largely water. 84) \_\_\_\_\_

85) Hemophilia is commonly called "bleeder's disease." 85) \_\_\_\_\_

86) Universal donors can receive blood groups A, B, AB, and O. 86) \_\_\_\_\_





Match the following blood types:

103) The blood type that can receive blood types B and O only      A) Blood type B      103) \_\_\_\_\_

Match the following function with its blood cell:

104) Active phagocytes that become macrophages      A) eosinophils      104) \_\_\_\_\_

105) Transports oxygen bound to hemoglobin      B) leukocytes      105) \_\_\_\_\_

106) Transport carbon dioxide      C) lymphocytes      106) \_\_\_\_\_

107) Contain histamine      D) erythrocytes      107) \_\_\_\_\_

E) monocytes

F) basophils

Match the following blood types:

108) The blood type that has no antigens      A) Blood type O      108) \_\_\_\_\_

**ESSAY. Write your answer in the space provided or on a separate sheet of paper.**

109) List and describe the structure of the two major classifications of leukocytes.

110) Explain the antigen-antibody response as it relates to blood groups.

111) Describe the three phases of the normal blood-clotting process.

112) Explain the cause, effect, and treatment of hemophilia.

113) Scott's blood test shows that he has excess red blood cells. Identify and describe two causes of this disorder.

114) Joanna has learned that she has leukocytosis. Explain this disorder to her.

115) Describe ABO and Rh blood groups.

116) Discuss hemolytic disease of the newborn (erythroblastosis fetalis).

- 1) B
- 2) D
- 3) C
- 4) D
- 5) B
- 6) D
- 7) D
- 8) B
- 9) D
- 10) A
- 11) B
- 12) B
- 13) D
- 14) E
- 15) B
- 16) E
- 17) C
- 18) C
- 19) D
- 20) E
- 21) E
- 22) D
- 23) B
- 24) A
- 25) D
- 26) A
- 27) D
- 28) D
- 29) D
- 30) E
- 31) E
- 32) B
- 33) C
- 34) C
- 35) C
- 36) D
- 37) C
- 38) B
- 39) C
- 40) B
- 41) B
- 42) B
- 43) C
- 44) B
- 45) B
- 46) D
- 47) C
- 48) hematocrit
- 49) hemoglobin
- 50) physiologic jaundice
- 51) D

- 52) positive chemotaxis
- 53) AB
- 54) leukocytosis
- 55) A
- 56) leukocytes
- 57) albumin
- 58) hemostasis
- 59) A
- 60) anemia
- 61) diapedesis
- 62) positive
- 63) embolus
- 64) A
- 65) hemophilia
- 66) C
- 67) thrombocytopenia
- 68) B
- 69) polycythemia
- 70) antigens
- 71) O
- 72) C
- 73) B; O
- 74) hemolytic disease of the newborn
- 75) erthrocytes (RBCs)
- 76) A; C
- 77) hematopoiesis
- 78) FALSE
- 79) TRUE
- 80) TRUE
- 81) FALSE
- 82) FALSE
- 83) FALSE
- 84) TRUE
- 85) TRUE
- 86) FALSE
- 87) TRUE
- 88) FALSE
- 89) TRUE
- 90) TRUE
- 91) TRUE
- 92) TRUE
- 93) A
- 94) B
- 95) A
- 96) A
- 97) B
- 98) A
- 99) D
- 100) C
- 101) A
- 102) B
- 103) A

104) E

105) D

106) D

107) F

108) A

109) The two major groups are the granulocytes and the agranulocytes.

1. The granulocytes have lobed nuclei and granules in the cytoplasm.
2. The agranulocytes lack cytoplasmic granules. Their nuclei are more normal in shape (either spherical, oval, or kidney-shaped).

110) Antigens are surface proteins found on all cells including blood cells. In the case of blood groups, an individual's blood type reflects the presence or absence of specific antigens. An antigen-antibody response is initiated if the individual receives a transfusion of blood containing antigens that it identifies as being "foreign." Antibodies found in a person's blood bind to the foreign antigen, causing agglutination, or clumping. The antigen-antibody complexes clog the small blood vessels, and the foreign RBCs are lysed, releasing hemoglobin into the bloodstream. The most serious complication of a transfusion reaction is kidney failure due to blockage of the kidney tubules by the hemoglobin molecules.

111) Hemostasis involves three major phases. The first phase is platelet plug formation, in which platelets become "sticky" and cling to the site of injury. The second phase is the vascular spasm phase, in which serotonin released by the platelets causes the blood vessels to spasm and constrict, thus decreasing blood loss. The third phase is coagulation wherein thromboplastin interacts with PF3 and calcium, as well as other blood proteins, to form prothrombin activator. Prothrombin activator converts prothrombin to thrombin, which then joins with fibrinogen to form fibrin, the basis of the clot.

112) Hemophilia refers to several different hereditary bleeding disorders that can result from a lack of any of the factors needed for clotting. Hemophilia causes uncontrolled bleeding. Treatment involves transfusion of either fresh blood plasma or the specific purified clotting factor that the individual is missing.

113) Scott's disorder is polycythemia, which results from excess numbers of erythrocytes in the blood.

This disorder may result from:

1. Bone marrow cancer (called polycythemia vera)
2. Life at a high altitude where the air is thinner and less oxygen is available (called secondary polycythemia)

Increased sluggishness of the blood results from polycythemia.

114) Leukocytosis is a white blood cell disorder. It results when the total WBC count is above 11,000 cells per cubic millimeter of blood. Leukocytosis generally indicates a bacterial or viral infection in the body.

115) The blood groups are based on the presence or absence of specific surface antigens. Blood group A has type A antigens on their RBCs, blood group B has type B antigens on their RBCs, blood group AB has both type A and type B antigens on their RBCs, and blood group O lacks either type A or type B antigens. The Rh<sup>+</sup> blood group indicates the presence of the Rh antigens on their RBCs. Individuals belong to blood groups A, B, AB, or O, and they are also classified as either Rh<sup>+</sup> or Rh<sup>-</sup>.

116) Erythroblastosis fetalis results from Rh incompatibility between an Rh<sup>-</sup> woman and her Rh<sup>+</sup> baby. With delivery of the first such infant, the mother's blood becomes sensitized by the Rh<sup>+</sup> antigens of the infant and she begins forming anti-Rh<sup>+</sup> antibodies. With the second and subsequent pregnancies, in which the woman carries Rh<sup>+</sup> infants, the mother's antibodies cross the placenta and destroy the baby's RBCs. The baby becomes anemic and hypoxic, and brain damage and death may result unless fetal transfusions are performed. Prevention of problems in future pregnancies involves treatment of the Rh<sup>-</sup> woman with RhoGAM upon the birth of her first child to prevent sensitization and anti-Rh antibody formation.

Exam

Name \_\_\_\_\_

**MULTIPLE CHOICE. Choose the one alternative that best completes the statement or answers the question.**

- 1) The carotid artery is located in the: 1) \_\_\_\_\_  
A) groin                      B) leg                      C) abdomen                      D) armpit                      E) neck
  
- 2) Pulmonary veins: 2) \_\_\_\_\_  
A) split off the pulmonary trunk  
B) transport oxygenated blood to the heart  
C) return blood to the right atrium of the heart  
D) transport oxygenated blood to the lungs  
E) transport blood rich in carbon dioxide to the lungs
  
- 3) Which one of the following blood vessels in the fetus has the highest concentration of oxygen: 3) \_\_\_\_\_  
A) umbilical arteries  
B) inferior vena cava  
C) ductus venosus  
D) left atrium  
E) ductus arteriosus
  
- 4) Which one of the following is true concerning the lub–dup sounds of the heart: 4) \_\_\_\_\_  
A) the first sound is longer and louder and is caused by closure of the AV valves; the second sound is shorter and sharper and is caused by closure of the semilunar valves  
B) the first sound is shorter and sharper and is caused by closure of the tricuspid valve; the second sound is longer and louder and is caused by closure of the mitral valve  
C) they are caused by contraction of the ventricles, followed by contraction of the atria  
D) the first sound is longer and louder and is caused by closure of the tricuspid valve; the second sound is shorter and sharper and is caused by closure of the mitral valve  
E) the first sound is shorter and sharper and is caused by closure of the semilunar valves; the second sound is longer and louder and is caused by closure of the AV valves
  
- 5) Generalized vasoconstriction occurs as a result of: 5) \_\_\_\_\_  
A) a decrease in parasympathetic nervous system firing  
B) an increase in blood pressure  
C) an increase in sympathetic nervous system firing  
D) a decrease in sympathetic nervous system firing  
E) an increase in parasympathetic nervous system firing
  
- 6) Which of these arteries is NOT a branch of the abdominal aorta: 6) \_\_\_\_\_  
A) left common carotid artery  
B) inferior mesenteric artery  
C) common iliac arteries  
D) gonadal arteries  
E) renal arteries
  
- 7) The tricuspid valve is located between the: 7) \_\_\_\_\_  
A) right ventricle and the pulmonary trunk  
B) left ventricle and pulmonary artery  
C) right atrium and right ventricle  
D) right atrium and left atrium  
E) left ventricle and aorta

- 8) The brachial vein: 8) \_\_\_\_\_
- A) drains blood from the popliteal vein, then empties that blood into the external iliac vein
  - B) drains blood from the internal jugular vein, then empties that blood into the superior vena cava
  - C) drains blood from the popliteal vein, then empties that blood into the femoral vein
  - D) drains blood from the axillary vein, then empties that blood into the superior vena cava
  - E) drains blood from the radial and ulnar veins, then empties that blood into the axillary vein
- 9) Which one is the correct sequence going from the outermost to the innermost layer of a blood vessel wall: 9) \_\_\_\_\_
- A) tunica intima, tunica media, tunica externa
  - B) tunica externa, tunica media, tunica intima
  - C) tunica media, tunica intima, tunica externa
  - D) tunica externa, tunica intima, tunica media
  - E) tunica media, tunica externa, tunica intima
- 10) Which of the following reduces heart rate: 10) \_\_\_\_\_
- A) increased body temperature
  - B) thyroxine
  - C) exercise
  - D) high blood pressure
  - E) epinephrine
- 11) Which one of the following areas is NOT a pressure point: 11) \_\_\_\_\_
- A) renal artery
  - B) radial artery
  - C) posterior tibial artery
  - D) facial artery
  - E) dorsalis pedis artery
- 12) The thick layer of the heart wall that contains contractile cardiac muscle tissue is the: 12) \_\_\_\_\_
- A) VISCERAL PERICARDIUM
  - B) PARIETAL PERICARDIUM
  - C) EPICARDIUM
  - D) ENDOCARDIUM
  - E) MYOCARDIUM
- 13) The volume of blood pumped out by each ventricle with each beat of the heart is called the: 13) \_\_\_\_\_
- A) diastolic pressure
  - B) stroke volume
  - C) cardiac output
  - D) heart rate
  - E) cardiac cycle
- 14) The right and left renal veins empty blood from the: 14) \_\_\_\_\_
- A) common iliac vein
  - B) hepatic portal vein
  - C) inferior vena cava
  - D) vertebral vein
  - E) kidneys

- 15) What structure divides the left from the right ventricle: 15) \_\_\_\_\_  
A) tricuspid valve  
B) interatrial septum  
C) interventricular septum  
D) bicuspid valve  
E) chordae tendineae
- 16) Substances tend to leave the bloodstream at the arterial end of the capillary because: 16) \_\_\_\_\_  
A) blood pressure is higher at the arterial end of the capillary  
B) interstitial pressure is higher at the arterial end of the capillary  
C) the osmotic pressure of the blood is higher at the venular end of the capillary  
D) blood pressure is higher at the venular end of the capillary  
E) the osmotic pressure of the blood is higher at the arterial end of the capillary
- 17) Veins: 17) \_\_\_\_\_  
A) carry blood away from the heart  
B) transport oxygen-rich blood  
C) branch into smaller vessels called arterioles  
D) operate under high pressure  
E) often have valves to prevent the backflow of blood
- 18) Which one of the following vessels receives blood during right ventricular systole: 18) \_\_\_\_\_  
A) aorta  
B) coronary arteries  
C) pulmonary veins  
D) pulmonary trunk  
E) superior vena cava
- 19) In which one of the following blood vessels is blood pressure the highest: 19) \_\_\_\_\_  
A) arterioles      B) arteries      C) vena cava      D) capillaries      E) veins
- 20) Which one of the following is the main function of renin and aldosterone: 20) \_\_\_\_\_  
A) they are produced whenever blood pressure rises and ultimately cause an increase in blood volume and blood pressure  
B) they are produced whenever blood pressure falls and ultimately cause an increase in blood volume and blood pressure  
C) they are produced when blood pressure rises and have no long-term effect on blood volume and blood pressure  
D) they are produced whenever blood pressure rises and ultimately cause a decrease in blood volume and blood pressure  
E) they are produced whenever blood pressure falls and ultimately cause a decrease in blood volume and blood pressure
- 21) The sinoatrial node is located in the: 21) \_\_\_\_\_  
A) right atrium  
B) aorta  
C) right ventricle  
D) left atrium  
E) interventricular septum
- 22) A person with a heart rate of 75 beats per minute and a stroke volume of 60 mL per beat has a cardiac output of: 22) \_\_\_\_\_

- A) 0.8 mL/minute
- B) 4500 mL/minute
- C) 6000 mL/minute
- D) 120 mL/minute
- E) 1.25 mL/minute

- 23) The path of blood flow within the systemic vascular system is: 23) \_\_\_\_\_
- A) arterioles, arteries, capillary beds, veins, venules
  - B) arterioles, arteries, capillary beds, venules, veins
  - C) arteries, arterioles, capillary beds, veins, venules
  - D) arterioles, arteries, venules, veins, capillary beds
  - E) arteries, arterioles, capillary beds, venules, veins
- 24) When the ventricles contract, the bicuspid (mitral) valve prevents blood from flowing from the: 24) \_\_\_\_\_
- A) left ventricle to the left atrium
  - B) right ventricle to the right atrium
  - C) right atrium to the left atrium
  - D) left atrium to the right atrium
  - E) left ventricle to the right ventricle
- 25) Which one of the following blood vessels carries oxygenated blood: 25) \_\_\_\_\_
- A) inferior vena cava
  - B) pulmonary vein
  - C) pulmonary artery
  - D) coronary sinus
  - E) superior vena cava
- 26) The superior vena cava empties: 26) \_\_\_\_\_
- A) oxygenated blood into the left atrium
  - B) deoxygenated blood into the right ventricle
  - C) deoxygenated blood into the left atrium
  - D) deoxygenated blood into the right atrium
  - E) oxygenated blood into the left ventricle
- 27) A heart rate of over 100 beats per minute is called: 27) \_\_\_\_\_
- A) heart block
  - B) diastole
  - C) tachycardia
  - D) bradycardia
  - E) ischemia
- 28) An increase in parasympathetic activity (primarily by the vagus nerves) causes: 28) \_\_\_\_\_
- A) an increase in both heart rate and cardiac output
  - B) a decrease in both heart rate and cardiac output
  - C) a decrease in heart rate and an increase in cardiac output
  - D) an increase in heart rate and a decrease in cardiac output
  - E) no change in both heart rate and cardiac output
- 29) The external iliac vein receives blood from all of the following EXCEPT: 29) \_\_\_\_\_
- A) vertebral vein
  - B) fibular vein
  - C) anterior tibial vein



- D) popliteal vein
- E) femoral vein

- 30) Which one of the following represents the correct path for the transmission of an impulse in the intrinsic conduction system of the heart: 30) \_\_\_\_\_
- A) sinoatrial (SA) node, atrioventricular (AV) bundle, atrioventricular (AV) node, right and left bundle branches, Purkinje fibers
  - B) atrioventricular (AV) node, atrioventricular (AV) bundle, sinoatrial (SA) node, Purkinje fibers, right and left bundle branches
  - C) sinoatrial (SA) node, atrioventricular (AV) node, atrioventricular (AV) bundle, right and left bundle branches, Purkinje fibers
  - D) sinoatrial (SA) node, atrioventricular (AV) bundle, atrioventricular (AV) node, Purkinje fibers, right and left bundle branches
  - E) atrioventricular (AV) node, sinoatrial (SA) node, atrioventricular (AV) bundle, right and left bundle branches, Purkinje fibers
- 31) Which of the following blood vessels is a direct branch of the ascending aorta: 31) \_\_\_\_\_
- A) carotid artery
  - B) left coronary artery
  - C) right subclavian artery
  - D) both the right and left coronary arteries
  - E) right coronary artery
- 32) Which of these pathways correctly traces blood as it travels from the aortic arch to the left arm: 32) \_\_\_\_\_
- A) aortic arch, left subclavian artery, left axillary artery, left brachial artery
  - B) ascending aorta, right coronary arteries
  - C) aortic arch, brachiocephalic trunk, right common carotid artery
  - D) abdominal aorta, celiac trunk, left gastric artery
  - E) aortic arch, left common carotid artery, left internal carotid artery
- 33) The right AV valve is known as the: 33) \_\_\_\_\_
- A) pulmonary semilunar valve
  - B) aortic semilunar valve
  - C) tricuspid valve
  - D) bicuspid valve
  - E) mitral valve
- 34) Which one of the following does NOT receive blood directly from the aortic arch: 34) \_\_\_\_\_
- A) thoracic aorta
  - B) left subclavian artery
  - C) left common carotid artery
  - D) right common carotid artery
  - E) brachiocephalic artery
- 35) Which area of the heart receives blood from the systemic veins: 35) \_\_\_\_\_
- A) right ventricle
  - B) aorta
  - C) left ventricle
  - D) right atrium
  - E) left atrium
- 36) Which one of the following is caused by a decrease in venous return to the heart: 36) \_\_\_\_\_

- A) an increase in stroke volume and a decrease in cardiac output
- B) an increase in stroke volume and cardiac output
- C) a decrease in stroke volume and an increase in cardiac output
- D) a decrease in stroke volume and cardiac output
- E) no change in stroke volume and cardiac output

- 37) The layer of the heart wall synonymous with the visceral layer of the serous pericardium is: 37) \_\_\_\_\_
- A) endocardium
  - B) either endocardium or epicardium
  - C) parietal layer of the serous pericardium
  - D) myocardium
  - E) epicardium
- 38) Which one of the following are direct branches of the left coronary artery: 38) \_\_\_\_\_
- A) anterior interventricular and circumflex arteries
  - B) anterior interventricular and marginal arteries
  - C) anterior and posterior interventricular arteries
  - D) circumflex and marginal arteries
  - E) posterior interventricular and marginal arteries
- 39) The umbilical vein carries: 39) \_\_\_\_\_
- A) metabolic wastes and carbon dioxide from the fetus to the placenta
  - B) metabolic wastes and carbon dioxide from the placenta to the fetus
  - C) oxygen and nutrients from the placenta to the fetus
  - D) oxygen and nutrients from the fetus to the placenta
  - E) blood from the navel into the inferior vena cava
- 40) The mitral valve is normally closed: 40) \_\_\_\_\_
- A) when the ventricle is in diastole
  - B) when the atrium is contracting
  - C) when the ventricle is contracting
  - D) when the ventricle is in systole
  - E) by the movement of blood from the atrium to the ventricle
- 41) Blood travels to the stomach by way of the branch of the celiac trunk called the: 41) \_\_\_\_\_
- A) superior mesenteric artery
  - B) inferior mesenteric artery
  - C) left gastric artery
  - D) common hepatic artery
  - E) splenic artery
- 42) The aortic semilunar valve is composed of: 42) \_\_\_\_\_
- A) three cusps and opens when the right atrium contracts
  - B) two cusps and closes when blood is filling the pulmonary circuit
  - C) three cusps and opens when the left ventricle contracts
  - D) two cusps and opens when the right atrium contracts
  - E) two cusps and opens when the left ventricle contracts
- 43) The friction blood encounters as it flows through the vessels is called: 43) \_\_\_\_\_
- A) cardiac output
  - B) blood pressure
  - C) peripheral resistance

- D) diastolic pressure
- E) stroke volume

- 44) Which one of the following are the main functions of renin and angiotensin II: 44) \_\_\_\_\_
- A) blood pressure rises—this causes vasoconstriction and a decrease in blood pressure
  - B) blood pressure falls—this causes vasoconstriction and an increase in blood pressure
  - C) blood pressure falls—this causes vasodilation and an increase in blood pressure
  - D) blood pressure rises—this causes vasoconstriction and further increases blood pressure
  - E) blood pressure rises—this causes vasodilation and a decrease in blood pressure
- 45) Varicose veins are caused by: 45) \_\_\_\_\_
- A) orthostatic hypotension
  - B) a loss of elasticity in blood vessels
  - C) the accumulation of fatty substances within blood vessels
  - D) excessive production of the enzyme renin
  - E) incompetent venous valves

**SHORT ANSWER. Write the word or phrase that best completes each statement or answers the question.**

*Fill in the blank or provide a short answer:*

- 46) The complete circle of connecting vessels in the brain is called the \_\_\_\_\_. 46) \_\_\_\_\_
- 47) The vessel that drains blood from all body regions below the diaphragm muscle before emptying into the right atrium is the \_\_\_\_\_. 47) \_\_\_\_\_
- 48) The flow of blood through a capillary bed is called \_\_\_\_\_. 48) \_\_\_\_\_

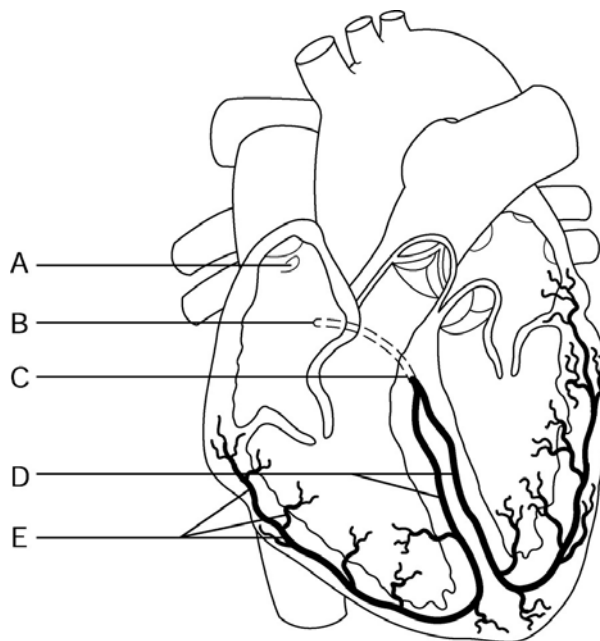

Figure 11.1

*Using Figure 11.1, identify the following:*

- 49) The sinoatrial (SA) node is indicated by letter \_\_\_\_\_. 49) \_\_\_\_\_

*Fill in the blank or provide a short answer:*

- 50) The flaplike opening in the interatrial septum of the fetus through which blood is shunted directly from the right atrium to the left atrium is the \_\_\_\_\_. 50) \_\_\_\_\_

- 51) During diastole, the pressure in the heart is \_\_\_\_\_.
- 52) \_\_\_\_\_ are abnormal heart sounds that are fairly common in young children with healthy hearts because their heart walls are relatively thin and vibrate with rushing blood.
- 53) Fluid tends to be forced out of a capillary bed by \_\_\_\_\_ while \_\_\_\_\_ tends to draw fluid into the capillary bed.
- 54) Larger veins have \_\_\_\_\_ to prevent the backflow of blood.
- 55) The single vessel that drains blood from the digestive tract organs to the liver is the \_\_\_\_\_.
- 56) The tiny white cords that anchor the cusps or flaps of endocardium to the walls of the ventricles are called the \_\_\_\_\_.

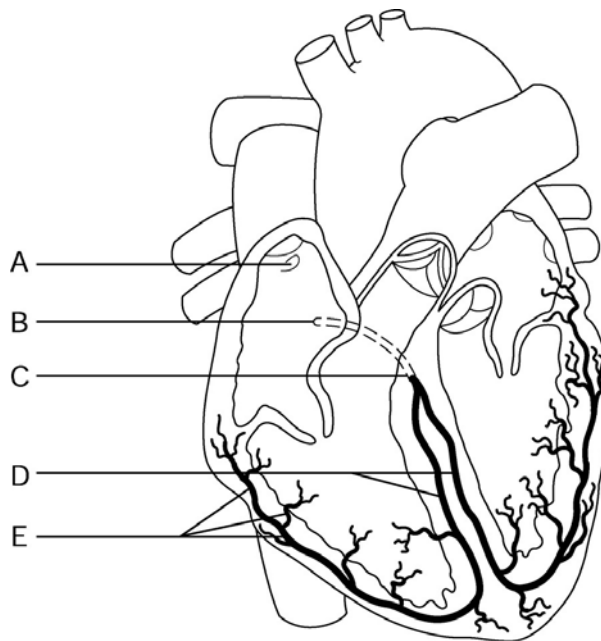

Figure 11.1

Using Figure 11.1, identify the following:

- 57) The Purkinje fibers are indicated by label \_\_\_\_\_.

Fill in the blank or provide a short answer:

- 58) The pressure blood exerts against the inner walls of the blood vessels is known as \_\_\_\_\_.
- 59) A systolic blood pressure reading below 100 mm HG is called \_\_\_\_\_.
- 60) The umbilical cord contains an umbilical \_\_\_\_\_ that transports oxygen and nutrient-rich blood to the fetus.
- 61) Lack of adequate blood supply to the heart is called \_\_\_\_\_.

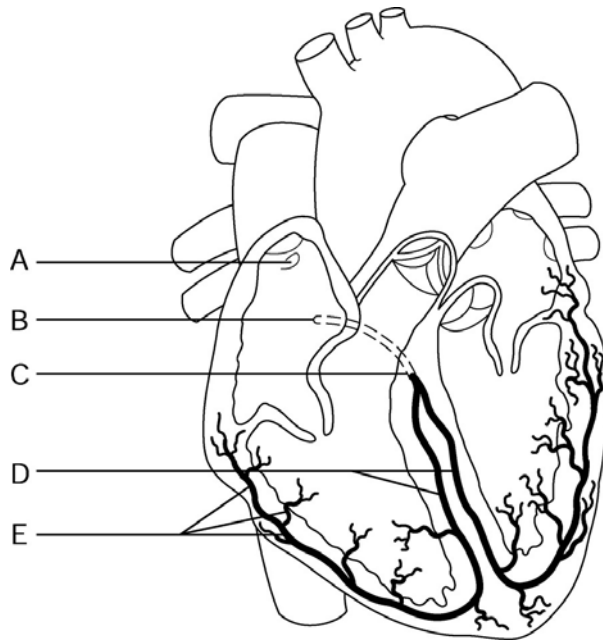

Figure 11.1

Using Figure 11.1, identify the following:

62) The bundle branches are indicated by letter \_\_\_\_\_. 62) \_\_\_\_\_

Fill in the blank or provide a short answer:

63) The circulation from the heart to the lungs and back is known as \_\_\_\_\_ circulation. 63) \_\_\_\_\_

64) The amount of blood being pumped out of the heart at any time is called \_\_\_\_\_. 64) \_\_\_\_\_

65) The hormones epinephrine and thyroxine will cause the heart rate to \_\_\_\_\_. 65) \_\_\_\_\_

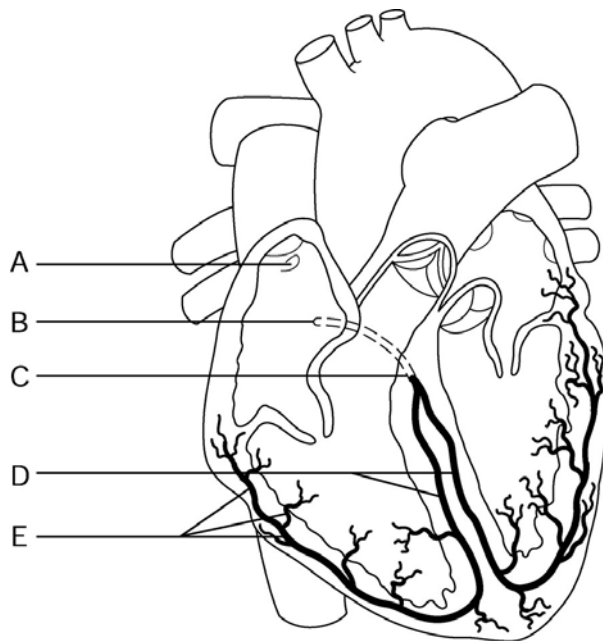

Figure 11.1

Using Figure 11.1, identify the following:

66) The atrioventricular (AV) node is indicated by letter \_\_\_\_\_. 66) \_\_\_\_\_

*Fill in the blank or provide a short answer:*

67) The coronary veins empty blood from the myocardium into a large vein on the posterior side of the heart known as the \_\_\_\_\_. 67) \_\_\_\_\_

68) Inflammation of varicose veins can result in a clot in that vessel; this condition is referred to as \_\_\_\_\_. 68) \_\_\_\_\_

69) A heart rate over 100 beats per minute is referred to as \_\_\_\_\_. 69) \_\_\_\_\_

70) The term that means heart contraction is \_\_\_\_\_. 70) \_\_\_\_\_

71) The visceral layer of the serous pericardium is actually the same layer as the \_\_\_\_\_. 71) \_\_\_\_\_

72) A decrease in the elasticity of blood vessels (i.e., increase in rigidity) causes arterial blood pressure to \_\_\_\_\_. 72) \_\_\_\_\_

73) The average heart beats about \_\_\_\_\_ times per minute. 73) \_\_\_\_\_

74) Cardiac output is the product of \_\_\_\_\_ and \_\_\_\_\_. 74) \_\_\_\_\_

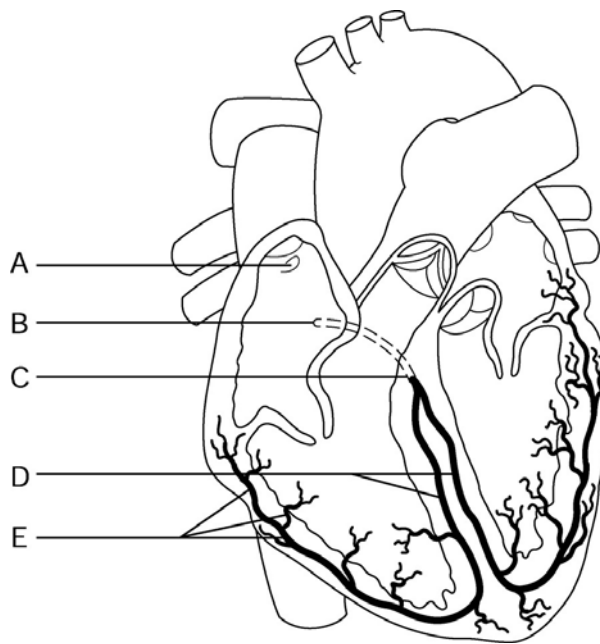

Figure 11.1

*Using Figure 11.1, identify the following:*

75) The specific chamber of the heart that is indicated by letter A is called the \_\_\_\_\_. 75) \_\_\_\_\_

*Fill in the blank or provide a short answer:*

76) The bicuspid valve is also referred to as the \_\_\_\_\_ valve. 76) \_\_\_\_\_

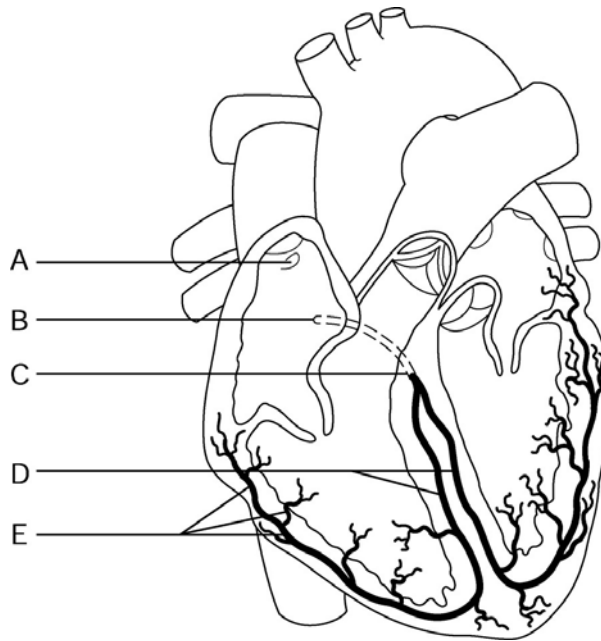

Figure 11.1

Using Figure 11.1, identify the following:

77) The layer of the heart wall that receives the stimulus from letter E is called the \_\_\_\_\_.

Fill in the blank or provide a short answer:

78) The pointed tip of the heart that is directed toward the left hip is called the \_\_\_\_\_.

79) The blood vessel that is the immediate inferior continuation of the external iliac artery is the \_\_\_\_\_.

80) Larger blood vessels that carry blood away from the heart are called \_\_\_\_\_.

81) The \_\_\_\_\_ veins join to form the superior vena cava before emptying into the right atrium.

82) The valves located between the atria and ventricles are known as the \_\_\_\_\_ valves.

83) The narrowing of blood vessels is known as \_\_\_\_\_.

84) The two superior receiving chambers of the heart are known as the \_\_\_\_\_, while the two inferior discharging chambers of the heart are known as the \_\_\_\_\_.

85) The electrocardiogram (ECG) wave that results from depolarization of the atria is the \_\_\_\_\_.

86) The innermost blood vessel wall that lines the lumen and consists of cells that fit closely together to form a slick surface that decreases friction and allows blood to flow smoothly is the \_\_\_\_\_.

87) The amount of friction blood encounters as it flows through the blood vessels is known as \_\_\_\_\_.

88) When ventricles \_\_\_\_\_, the AV valves are closed.

88) \_\_\_\_\_

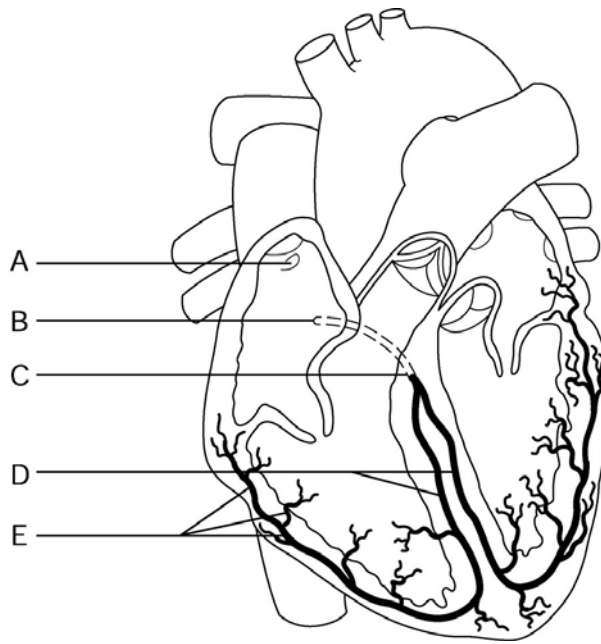

Figure 11.1

Using Figure 11.1, identify the following:

89) The partition where the bundle branches are located is called the \_\_\_\_\_.

89) \_\_\_\_\_

Fill in the blank or provide a short answer:

90) The sinoatrial node, located in the right atrium of the heart, is often called the \_\_\_\_\_.

90) \_\_\_\_\_

91) Crushing chest pain caused by oxygen deprivation of the myocardium is called \_\_\_\_\_.

91) \_\_\_\_\_

92) The smallest blood vessels known as \_\_\_\_\_ connect arterioles and venules.

92) \_\_\_\_\_

**TRUE/FALSE. Write 'T' if the statement is true and 'F' if the statement is false.**

93) The pacemaker of the heart under normal circumstances is called the sinoatrial (SA) node.

93) \_\_\_\_\_

94) The circle of Willis involves blood flow through the liver.

94) \_\_\_\_\_

95) The major vessels involved in hepatic portal circulation are the inferior and superior mesenteric arteries, the splenic artery, and the left gastric artery.

95) \_\_\_\_\_

96) Cardiac muscle is enclosed by a double sac of serous membrane known as the peritoneum.

96) \_\_\_\_\_

97) Exchanges between blood and tissue cells occur in capillary beds.

97) \_\_\_\_\_

98) Reductions in venous return cause reductions in both stroke volume and cardiac output.

98) \_\_\_\_\_

99) Systole means contraction of the ventricles.

99) \_\_\_\_\_

100) An increased firing of the parasympathetic nervous system causes increased cardiac output.

100) \_\_\_\_\_



- 101) Cold temperatures have a vasoconstricting effect on blood vessels. 101) \_\_\_\_
- 102) Hypotension is diastolic blood pressure below 100 mm Hg. 102) \_\_\_\_
- 103) The chordae tendineae anchor the semilunar valves to the walls of the ventricles. 103) \_\_\_\_
- 104) Veins draining the head and arms empty into the inferior vena cava. 104) \_\_\_\_
- 105) Cardiac output is calculated by multiplying the stroke volume times the systolic blood pressure. 105) \_\_\_\_
- 106) In fetal circulation, blood travels directly from the right atrium to the left atrium through the foramen ovale. 106) \_\_\_\_
- 107) Smooth muscle and elastic tissue in a blood vessel wall is found primarily in the tunica media. 107) \_\_\_\_
- 108) The coronary sinus on the backside of the heart drains deoxygenated blood from the wall of the heart into the left atrium. 108) \_\_\_\_
- 109) The semilunar valves prevent the backflow of blood into the atria when the ventricles are contracting. 109) \_\_\_\_
- 110) The portion of the aorta in the abdominopelvic cavity is known as the thoracic aorta. 110) \_\_\_\_
- 111) The coronary sulcus is also known as the atrioventricular groove. 111) \_\_\_\_
- 112) The part of the intrinsic conduction system of the heart that directly supplies the walls of the ventricles is the Purkinje fibers. 112) \_\_\_\_
- 113) When precapillary sphincters are closed, blood flows through the shunts and bypasses the tissue cells. 113) \_\_\_\_
- 114) The three branches of the aortic arch are the brachiocephalic trunk, left common carotid artery, and the left subclavian artery. 114) \_\_\_\_
- 115) The umbilical vein carries blood rich in nutrients and oxygen to the fetus. 115) \_\_\_\_
- 116) The common iliac vein drains blood into the inferior vena cava. 116) \_\_\_\_
- 117) The superior and inferior mesenteric arteries drain blood from the intestines. 117) \_\_\_\_
- 118) The great saphenous vein, the longest vein in the body, drains deoxygenated blood from the dorsal venous arch in the foot which then empties into the femoral vein. 118) \_\_\_\_
- 119) The tricuspid valve is located on the right side of the heart between the right atrium and right ventricle. 119) \_\_\_\_
- 120) Arteries always carry blood away from the heart. 120) \_\_\_\_
- 121) Diastolic blood pressure is the pressure in the arteries at the peak of ventricular contraction. 121) \_\_\_\_
- 122) The pulmonary arteries carry deoxygenated blood to the lungs. 122) \_\_\_\_

123) During ventricular diastole, the bicuspid and tricuspid valves are closed. 123) \_\_\_\_

124) The larger arteries contain valves to prevent the backflow of blood. 124) \_\_\_\_

125) An increase in blood vessel diameter causes arterial blood pressure to decrease. 125) \_\_\_\_

**MATCHING. Choose the item in column 2 that best matches each item in column 1.**

*Match the following:*

126) These vessels carry blood away from the heart A) arteries 126) \_\_\_\_

*Match the following:*

127) Part of the cardiac cycle when the bicuspid and tricuspid valves are open A) ventricular systole 127) \_\_\_\_

B) ventricular diastole

*Match the following:*

128) Aldosterone causes blood volume to A) increase 128) \_\_\_\_

*Match the following:*

129) Heart chamber with the thickest wall A) left ventricle 129) \_\_\_\_

*Match the following:*

130) Some of these larger vessels have valves to prevent backflow A) capillaries 130) \_\_\_\_

B) veins

131) Venules drain these tiny vessels 131) \_\_\_\_

132) Blood pressure in these vessels is low 132) \_\_\_\_

133) These vessels return blood to the heart 133) \_\_\_\_

134) Nutrient and gas exchange occur in these vessels 134) \_\_\_\_

135) These vessels have thinner walls and transport oxygen-poor blood A) veins 135) \_\_\_\_

B) arteries

136) Superior and inferior vena cava are classified as these types of vessels 136) \_\_\_\_

137) These vessels have thicker walls and a heavier tunica media 137) \_\_\_\_

*Match the following:*

138) An increase in vagus nerve firing causes heart rate to A)decrea

se 138)

\_\_\_\_  
-

*Match the following:*

139) Part of the cardiac cycle when both of the semilunar valves are closed

A) ventricular diastole

139) \_\_\_\_

B) ventricular systole

140) Part of the cardiac cycle when the coronary system is emptying of blood

140) \_\_\_\_

*Match the following:*

141) Heart chamber that pumps blood to the pulmonary trunk

A) right ventricle

141) \_\_\_\_

*Match the following:*

142) A decrease in peripheral resistance causes arterial blood pressure to

A) decrease

142) \_\_\_\_

*Match the following:*

143) This chamber sends blood into the aorta

A) left ventricle

143) \_\_\_\_

144) Superior discharging chamber on the left side of the heart

144) \_\_\_\_

145) Roof of this chamber contains the bicuspid valve

145) \_\_\_\_

*Match the following:*

146) Epinephrine and thyroxine cause both heart rate and cardiac output to

A) increase

146) \_\_\_\_

*Match the following:*

147) Heart chamber that contains the sinoatrial node

A) right atrium

147) \_\_\_\_

*Match the following:*

148) An increase in sympathetic nervous system firing causes cardiac output to

A) increase

148) \_\_\_\_

*Match the following:*

149) The aorta is classified as one of these vessels

A) arteries

149) \_\_\_\_

Match the following:

150) Salt causes both blood volume and arterial blood pressure to \_\_\_\_\_ A) increase 150) \_\_\_\_\_

151) An increase in the deposition of saturated fats in the lining of blood vessels causes arterial blood pressure to \_\_\_\_\_ 151) \_\_\_\_\_

Match the following:

152) The four pulmonary veins return oxygenated blood to this chamber \_\_\_\_\_ A) right atrium 152) \_\_\_\_\_

153) The coronary sinus empties blood from cardiac circulation into this chamber \_\_\_\_\_ B) left atrium 153) \_\_\_\_\_

**ESSAY. Write your answer in the space provided or on a separate sheet of paper.**

154) Trace a drop of blood from the aorta to the stomach.

155) Explain how pulmonary circulation differs from systemic circulation.

156) Discuss the events that are taking place in the cardiac cycle during the left ventricular systole. Indicate whether the other heart chambers are in systole or diastole and whether they are filling or emptying of blood. If they are emptying, state where the blood is going. If they are filling with blood, state where the blood is coming from. Include an explanation of which valves are open and which valves are closed, in addition to whether the coronary system is filling or emptying of blood.

157) Identify the five major parts of the intrinsic conduction system of the heart in their normal order, beginning with the pacemaker.

158) Define *peripheral resistance*. Explain several factors that cause it to increase and its effect on arterial blood pressure.

159) Explain the role of valves in heart functioning.

160) Trace the path of a drop of blood, starting at the right atrium and returning to the right atrium, through the pulmonary and systemic circuits of the cardiovascular system. Identify the chambers, valves, and vessels (except specific systemic blood vessels that are not directly associated with the heart), and indicate whether the blood is oxygenated or deoxygenated in each area.

- 1) E
- 2) B
- 3) C
- 4) A
- 5) C
- 6) A
- 7) C
- 8) E
- 9) B
- 10) D
- 11) A
- 12) E
- 13) B
- 14) C
- 15) C
- 16) A
- 17) E
- 18) D
- 19) B
- 20) B
- 21) A
- 22) B
- 23) E
- 24) A
- 25) B
- 26) D
- 27) C
- 28) B
- 29) A
- 30) C
- 31) D
- 32) A
- 33) C
- 34) D
- 35) D
- 36) D
- 37) E
- 38) A
- 39) C
- 40) D
- 41) C
- 42) C
- 43) C
- 44) B
- 45) E
- 46) circle of Willis or cerebral arterial circle
- 47) inferior vena cava
- 48) microcirculation
- 49) A
- 50) foramen ovale
- 51) low

- 52) Heart murmurs
- 53) blood pressure; osmotic pressure
- 54) valves
- 55) hepatic portal vein
- 56) chordae tendineae
- 57) E
- 58) blood pressure
- 59) hypotension
- 60) vein
- 61) ischemia
- 62) D
- 63) pulmonary
- 64) cardiac output
- 65) increase
- 66) B
- 67) coronary sinus
- 68) thrombophlebitis
- 69) tachycardia
- 70) systole
- 71) epicardium
- 72) increase
- 73) 75
- 74) heart rate (HR); stroke volume (SR)
- 75) right atrium
- 76) mitral
- 77) myocardium
- 78) apex
- 79) femoral artery
- 80) arteries
- 81) brachiocephalic
- 82) atrioventricular (or AV)
- 83) vasoconstriction
- 84) atria; ventricles
- 85) P wave
- 86) tunica intima
- 87) peripheral resistance
- 88) contract
- 89) interventricular septum
- 90) pacemaker
- 91) angina pectoris
- 92) capillaries
- 93) TRUE
- 94) FALSE
- 95) FALSE
- 96) FALSE
- 97) TRUE
- 98) TRUE
- 99) TRUE
- 100) FALSE
- 101) TRUE
- 102) FALSE
- 103) FALSE

- 104) FALSE
- 105) FALSE
- 106) TRUE
- 107) TRUE
- 108) FALSE
- 109) FALSE
- 110) FALSE
- 111) TRUE
- 112) TRUE
- 113) TRUE
- 114) TRUE
- 115) TRUE
- 116) TRUE
- 117) FALSE
- 118) TRUE
- 119) TRUE
- 120) TRUE
- 121) FALSE
- 122) TRUE
- 123) FALSE
- 124) FALSE
- 125) TRUE
- 126) A
- 127) B
- 128) A
- 129) A
- 130) B
- 131) A
- 132) B
- 133) B
- 134) A
- 135) B
- 136) B
- 137) C
- 138) A
- 139) A
- 140) B
- 141) A
- 142) A
- 143) A
- 144) A
- 145) A
- 146) A
- 147) A
- 148) A
- 149) A
- 150) A
- 151) A
- 152) B
- 153) A
- 154) Blood leaves the aorta (the aorta becomes the aortic arch, thoracic aorta, then the abdominal aorta). It travels to the celiac trunk, the first branch of the abdominal aorta. The blood travels via the left gastric artery to the stomach.

- 155) 1. The right side of the heart deals with pulmonary circulation. The right atrium receives oxygen-poor blood from systemic veins and sends it to the right ventricle. The right ventricle sends this blood out through the pulmonary trunk. The pulmonary trunk branches into pulmonary arteries, which carry blood to the lungs. In the lungs, oxygen is loaded into the bloodstream while carbon dioxide is unloaded. The oxygen-rich blood returns to the left atrium of the heart via the pulmonary veins, completing pulmonary circulation.
2. The left ventricle sends oxygenated blood out to the body via the aorta to begin systemic circulation. This blood travels in arteries, which branch into arterioles. Arterioles feed the capillary beds where nutrient and gas exchange occurs. The oxygen-poor blood drains into the venules, which empty blood into the veins. Veins finally empty into the superior vena cava and inferior vena cava, which return blood into the right atrium of the heart from systemic circulation.
- 156) When the left ventricle is in systole, oxygenated blood is leaving the left ventricle and entering the aorta. At that time, the aortic semilunar valve is open and the bicuspid valve is closed. The right ventricle is also in systole and deoxygenated blood is leaving the right ventricle and entering the pulmonary trunk. At that time, the pulmonary semilunar valve is open and the tricuspid valve is closed. When the ventricles are in systole, both the right and left atria are in diastole. The right atrium is filling with deoxygenated blood, which is returning to this chamber via the coronary sinus and the superior and inferior vena cava. The left atrium is filling with oxygenated blood that is returning to the heart from the lungs via the pulmonary veins. Finally, during ventricular systole, blood is leaving the coronary system and entering the right side of the heart via the coronary sinus.
- 157) Sinoatrial (SA) node in the right atrium, atrioventricular (AV) node at the junction of the atria and ventricles, atrioventricular (AV) bundle or bundle of His in the interventricular septum, right and left bundle branches in the interventricular septum, Purkinje fibers in the muscle of the ventricle walls.
- 158) Peripheral resistance is the amount of friction encountered by blood as it flows through the blood vessels. Probably the most important factor that increases peripheral resistance is the narrowing of the diameter of a blood vessel (mainly by arterioles), which is called vasoconstriction. Vasoconstriction occurs normally due to an increase in sympathetic nervous system firing. It can also occur abnormally in atherosclerosis. Another factor that causes an increase in peripheral resistance is increased volume of blood in the vascular system or increased viscosity (thickness) of the blood. Regardless of the cause of this increase in peripheral resistance, the result is an increase in arterial blood pressure.
- 159) Valves allow blood to flow in one direction through the heart chambers (from atria to ventricles) and out the two arteries leaving the heart.
- There are two types of valves found in the heart:
1. The atrioventricular, or AV, valves are located between the atrium and ventricle on each side of the heart. These valves prevent the backflow of blood into the atria when the heart contracts. In summary, these AV valves are open during heart relaxation and closed during heart contraction.
2. The semilunar valves guard the base of the two large arteries, aorta and pulmonary trunk, leaving the heart via the two ventricles. These valves close after blood has passed through the arteries on its way out of the heart. They prevent the backflow of blood into the ventricles from the arteries. In summary, these valves are closed during heart relaxation and open during heart contraction.
- 160) Deoxygenated blood in the right atrium, deoxygenated blood through the pulmonary tricuspid valve, deoxygenated blood in the right ventricle, deoxygenated blood through the pulmonary semilunar valve, deoxygenated blood in the pulmonary trunk, deoxygenated blood in the right and left pulmonary arteries, deoxygenated blood in the pulmonary capillaries in the lungs, oxygenated blood in the pulmonary veins, oxygenated blood in the left atrium, oxygenated blood through the bicuspid (mitral) valve, oxygenated blood in the left ventricle, oxygenated blood through the aortic semilunar valve, oxygenated blood in the aorta, oxygenated blood in the systemic arteries, oxygenated blood in the systemic arterioles, oxygenated blood in the systemic capillaries, deoxygenated blood in the systemic venules, deoxygenated blood in the systemic veins, deoxygenated blood in the superior and inferior vena cava, deoxygenated blood in the right atrium.



Exam

Name \_\_\_\_\_

**MULTIPLE CHOICE. Choose the one alternative that best completes the statement or answers the question.**

- 1) The specific foreign substances that an individual's immune system has the ability to recognize and resist is determined by: 1) \_\_\_\_\_
  - A) the total number of lymphocytes present at a given time
  - B) individual exposure to the specific foreign substance
  - C) the total number of macrophages at a given time
  - D) individual genetic makeup
  - E) the total number of self-antigens at a given time
  
- 2) The body's first line of defense against the invasion of disease-causing microorganisms is: 2) \_\_\_\_\_
  - A) phagocytes
  - B) skin and mucous membranes
  - C) natural killer cells
  - D) fever
  - E) inflammatory response
  
- 3) Which of these lymphoid organs is found along the left side of the abdominal cavity: 3) \_\_\_\_\_
  - A) Peyer's patches
  - B) axillary lymph nodes
  - C) tonsils
  - D) thymus gland
  - E) spleen
  
- 4) Which one of the following is NOT an autoimmune disease: 4) \_\_\_\_\_
  - A) AIDS
  - B) rheumatoid arthritis
  - C) type I diabetes mellitus
  - D) Graves' disease
  - E) multiple sclerosis
  
- 5) Which one of the following is NOT true of macrophages: 5) \_\_\_\_\_
  - A) they are considered the "big eaters" of the immune system
  - B) they engulf foreign particles
  - C) they circulate continuously throughout the body
  - D) they secrete monokines
  - E) they act as antigen presenters
  
- 6) Lymph flows: 6) \_\_\_\_\_
  - A) toward the heart only
  - B) in a circular pattern within the tissues
  - C) away from the heart only
  - D) both toward and away from the heart
  - E) into the capillaries
  
- 7) Which one of the following is NOT one of the four most common indicators of the inflammatory response: 7) \_\_\_\_\_
  - A) redness
  - B) heat
  - C) swelling
  - D) pain
  - E) fever
  
- 8) Regardless of whether it matures into a B cell or a T cell, a lymphocyte that is capable of responding \_\_\_\_\_

to a  
specific  
antigen  
by  
binding  
to it is  
said to  
be:

- A) immunocompetent
- B) immune
- C) incompetent
- D) complemented
- E) clonal

—  
—  
—  
—

- 8) \_\_\_\_\_
- 9) Allergic contact dermatitis following skin contact with poison ivy would normally lead to: 9) \_\_\_\_\_
- A) immediate hypersensitivity
  - B) anaphylactic shock
  - C) immunodeficiency
  - D) delayed hypersensitivity
  - E) acute hypersensitivity
- 10) The specific type of acquired immunity that a fetus obtains from maternal antibodies that cross the placenta is called: 10) \_\_\_\_\_
- A) naturally acquired active immunity
  - B) artificially acquired passive immunity
  - C) naturally acquired passive immunity
  - D) artificially acquired active immunity
  - E) artificially acquired natural immunity
- 11) Which one of the following is NOT a mechanism that aids lymph return: 11) \_\_\_\_\_
- A) smooth muscle contractions within the lymphatic vessels
  - B) milking action of skeletal muscles
  - C) pressure changes within the thorax
  - D) the pumping action of the heart
  - E) presence of valves within the larger lymph vessels
- 12) The body's temperature-regulating "thermostat" that can be reset upward in response to pyrogens is located in the: 12) \_\_\_\_\_
- A) medulla oblongata
  - B) thalamus
  - C) cerebellum
  - D) pineal gland
  - E) hypothalamus
- 13) The specific antibody class that has the ability to cross the placental barrier and provide immunity to the fetus is: 13) \_\_\_\_\_
- A) IgG                      B) IgM                      C) IgD                      D) IgE                      E) IgA
- 14) The inflammatory process begins with release of chemicals, which do all of the following EXCEPT: 14) \_\_\_\_\_
- A) attract phagocytes to the area
  - B) cause capillaries to become leaky

- C) activate pain receptors
- D) dilate blood vessels
- E) stimulate release of lysozyme

- 15) Compared to the nonspecific chemicals that cover body surfaces and mucous membranes, the specific body defense system is: 15) \_\_\_\_\_
- A) sometimes faster and sometimes slower
  - B) slower
  - C) the same speed
  - D) faster
  - E) not comparable in speed
- 16) Which one of the following is NOT true of basic antibody structure: 16) \_\_\_\_\_
- A) they consist of four amino acid chains
  - B) the heavy chains are identical
  - C) the heavy chains are about 400 amino acids long
  - D) they are linked together by disulfide bonds
  - E) the light chains are often of differing lengths
- 17) Which one of the following is NOT a type of immunosuppressive therapy given after surgery to prevent rejection of a graft: 17) \_\_\_\_\_
- A) antiproliferative drugs
  - B) gamma globulin
  - C) immunosuppressive drugs
  - D) radiation
  - E) corticosteroids
- 18) Vaccines are NOT for: 18) \_\_\_\_\_
- A) snake bites
  - B) polio
  - C) measles
  - D) pneumonia
  - E) tetanus
- 19) B cells develop immunocompetence in the: 19) \_\_\_\_\_
- A) spleen
  - B) bone marrow
  - C) lymph nodes
  - D) thyroid gland
  - E) thymus gland
- 20) Which one of the following CANNOT be said about the history of immunity: 20) \_\_\_\_\_
- A) scientists of the 1800s demonstrated that immune serum could protect another animal from disease
  - B) scientists of the mid-1900s discovered that injection of serum containing antibodies did NOT always protect a recipient from disease
  - C) scientists of the mid-1900s discovered the viral origin of AIDS
  - D) scientists of the 1800s discovered "factors" now called antibodies
  - E) the ancient Greeks knew something existed within the body to protect it from infectious disease
- 21) The relatively common autoimmune disease in which the thyroid gland produces excessive amounts

of 21) \_\_\_\_\_  
thyroxin \_\_\_\_\_  
e is  
called:

- A) Graves' disease
- B) myasthenia gravis
- C) multiple sclerosis
- D) systemic lupus erythematosus
- E) glomerulonephritis

22) Antigen presentation is essential for the activation and clonal selection of:

22) \_\_\_\_\_

- A) antibodies
- B) B cells
- C) plasma cell
- D) antigen-presenting cells
- E) T cells

23) Which of the following substances is NOT typically perceived as an antigen:

23) \_\_\_\_\_

- A) pollen grains
- B) virus particles
- C) fungi
- D) self-antigens
- E) bacteria

24) Mucosa-associated lymphatic tissue (MALT) includes:

24) \_\_\_\_\_

- A) spleen
- B) tonsils and Peyer's patches
- C) tonsils only
- D) thymus gland
- E) tonsils and spleen

25) Lymph from the left arm would return to the heart through the:

25) \_\_\_\_\_

- A) thoracic duct
- B) aorta
- C) left subclavian artery
- D) right lymphatic duct
- E) inferior vena cava

26) The process by which neutrophils are squeezed through the capillary walls during the inflammatory process is called:

26) \_\_\_\_\_

- A) coagulation
- B) diapedesis
- C) agglutination
- D) chemotaxis
- E) antibody production

27) Which one of the following is NOT a method by which antibodies inactivate antigens:

27) \_\_\_\_\_

- A) agglutination
- B) chemotaxis
- C) precipitation
- D) neutralization
- E) complement fixation

- 28) Which one of the following is NOT a type of lymphoid organ: 28) \_\_\_\_\_
- A) spleen
  - B) thymus gland
  - C) Peyer's patches
  - D) appendix
  - E) tonsils
- 29) Immune sera are used for all of the following EXCEPT: 29) \_\_\_\_\_
- A) tuberculosis
  - B) botulism
  - C) snake bites
  - D) rabies
  - E) tetanus
- 30) The process by which antibodies bind to specific sites on bacterial exotoxins (toxic chemicals secreted by bacteria) to block their harmful effects is called: 30) \_\_\_\_\_
- A) chemotaxis
  - B) precipitation
  - C) agglutination
  - D) neutralization
  - E) complement fixation
- 31) Which one of the following is NOT true of lymph nodes: 31) \_\_\_\_\_
- A) they contain macrophages
  - B) they act as filters along the lymphatic vessels
  - C) they remove foreign materials from the lymph fluid
  - D) they have valves similar to those found in veins
  - E) they contain lymphocytes
- 32) Which one of the following is NOT one of the antibody classes: 32) \_\_\_\_\_
- A) IgG                      B) IgD                      C) IgB                      D) IgA                      E) IgE
- 33) The lymph organ that programs T cells and functions at peak levels only during youth is the: 33) \_\_\_\_\_
- A) spleen
  - B) thymus
  - C) Peyer's patches
  - D) appendix
  - E) tonsils
- 34) An isograft is a tissue graft donated by: 34) \_\_\_\_\_
- A) an unrelated person
  - B) an identical twin
  - C) a different animal species
  - D) a parent
  - E) the same person
- 35) The fluid that is forced out of the capillary beds by hydrostatic and osmotic pressures and into the tissue spaces is called: 35) \_\_\_\_\_
- A) venous blood
  - B) arterial blood
  - C) interstitial fluid

- D) plasma
- E) lymph

- 36) Which lymphoid tissues trap and remove bacteria entering the throat: 36) \_\_\_\_\_
- A) cervical lymph nodes
  - B) tonsils
  - C) axillary lymph nodes
  - D) Peyer's patches
  - E) thymus gland
- 37) Which one of the following is NOT one of the nonspecific body defenses: 37) \_\_\_\_\_
- A) antibody production
  - B) natural killer cells
  - C) the inflammatory response
  - D) intact skin
  - E) fever
- 38) IgA: 38) \_\_\_\_\_
- A) is passed from mother to fetus during pregnancy
  - B) is involved in allergies
  - C) is the most abundant antibody in blood plasma
  - D) can fix complement
  - E) is mainly found in mucus and secretions such as tears and saliva
- 39) Fever has the effect of doing all of the following EXCEPT: 39) \_\_\_\_\_
- A) denaturing (scrambling) proteins
  - B) stimulating the liver and spleen to gather up iron and zinc
  - C) stimulating complement fixation
  - D) speeding up repair processes
  - E) increasing metabolic rate of tissue cells
- 40) The migration of phagocytes and white blood cells to an inflamed area along a chemical gradient is called: 40) \_\_\_\_\_
- A) diapedesis
  - B) perforins
  - C) complement fixation
  - D) immunity
  - E) chemotaxis
- 41) Tissues invaded by viruses, which attempt to replicate themselves by taking over cellular machinery, secrete small proteins called \_\_\_\_\_ to protect nearby cells and hinder further multiplication of the viruses. 41) \_\_\_\_\_
- A) kinins
  - B) histamine
  - C) interleukins
  - D) pyrogens
  - E) interferon
- 42) What specific type of acquired immunity do vaccines provide: 42) \_\_\_\_\_
- A) naturally acquired artificial immunity
  - B) naturally acquired passive immunity
  - C) artificially acquired passive immunity

- D) artificially acquired active immunity
- E) naturally acquired active immunity

- 43) Which one of the following is NOT true of the constant (C) regions of antibodies: 43) \_\_\_\_\_
- A) they are the same or nearly the same
  - B) they form the "stem" of an antibody
  - C) they determine how an antibody class will carry out its immune role
  - D) they form an antigen-binding site
  - E) they determine the specific type of antibody class formed
- 44) With immediate hypersensitivity, the antibody class that binds to mast cells and basophils that trigger the release of histamine and other chemicals is: 44) \_\_\_\_\_
- A) IgE
  - B) IgD
  - C) IgG
  - D) IgM
  - E) IgA
- 45) The study of immunity is called: 45) \_\_\_\_\_
- A) histology
  - B) anatomy
  - C) immunology
  - D) pathology
  - E) microbiology
- 46) The lymph tissues found within the walls of the small intestine are called: 46) \_\_\_\_\_
- A) Peyer's patches
  - B) tonsils
  - C) appendix
  - D) thymus tissues
  - E) intestinal nodes
- 47) Which lymphatic organ's major job is to destroy worn-out red blood cells and return some of the products to the liver: 47) \_\_\_\_\_
- A) tonsils
  - B) Peyer's patches
  - C) thymus gland
  - D) tonsils
  - E) spleen

**SHORT ANSWER. Write the word or phrase that best completes each statement or answers the question.**

*Fill in the blank or provide a short answer:*

- 48) Antibodies constitute an important part of blood proteins and are also referred to as \_\_\_\_\_ 48) \_\_\_\_\_
- 49) Antigens that produce abnormally vigorous immune responses whereby the immune system causes tissue damage as it fights off a perceived threat that would otherwise be harmless are called \_\_\_\_\_. 49) \_\_\_\_\_
- 50) Systemic (bodywide) acute allergic response caused by allergens that directly enter the blood, as with certain bee stings or spider bites, is called \_\_\_\_\_. 50) \_\_\_\_\_
- 51) Cells studded with protein molecules found on our own cells that do not trigger an immune response within us (but may within others) are called \_\_\_\_\_. 51) \_\_\_\_\_
- 52) The fibrous capsule of lymph nodes contains strands called \_\_\_\_\_ that divide the node into \_\_\_\_\_ 52) \_\_\_\_\_

compart 52)  
ments.

—  
—  
—  
—  
—

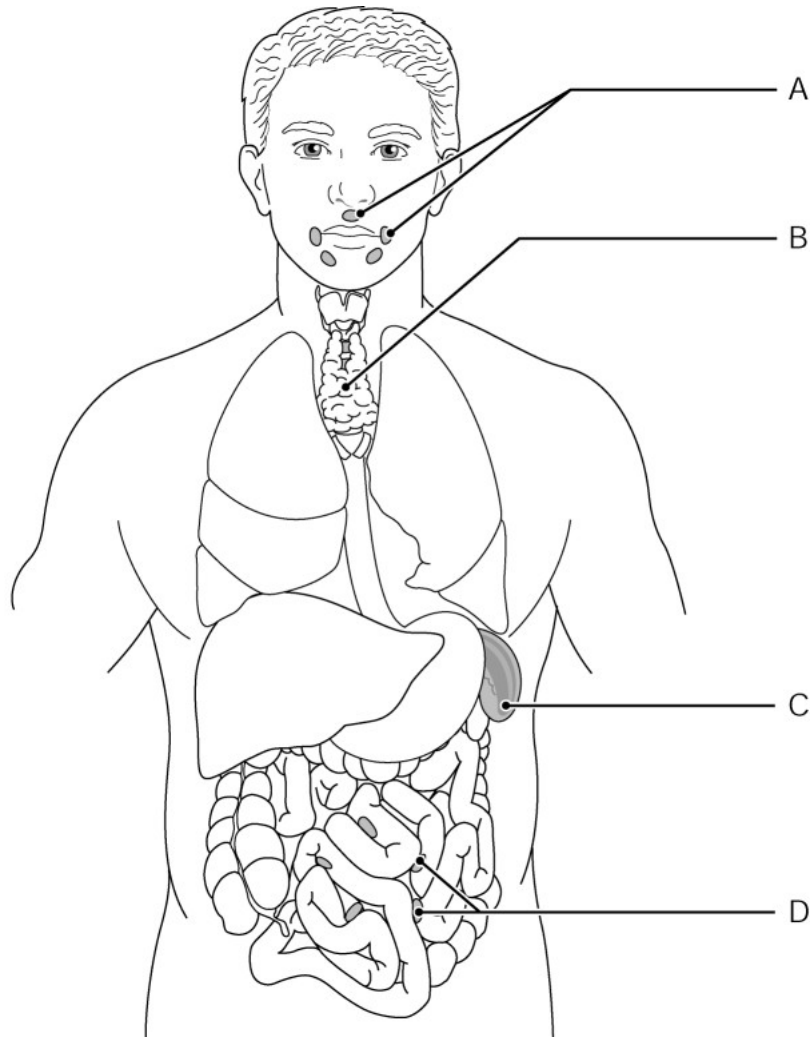

Figure 12.2

**Using Figure 12.2, identify the following:**

53) The Peyer's patches are indicated by letter \_\_\_\_\_.

53) \_\_\_\_\_

*Fill in the blank or provide a short answer:*

54) Troublesome small molecules or incomplete antigens that may mount an attack that is harmful rather than protective are called \_\_\_\_\_.

54) \_\_\_\_\_

55) Peyer's patches and the tonsils are part of the collection of small lymphoid tissues that protect the upper respiratory and digestive tracts from infection and are referred to as \_\_\_\_\_.

55) \_\_\_\_\_



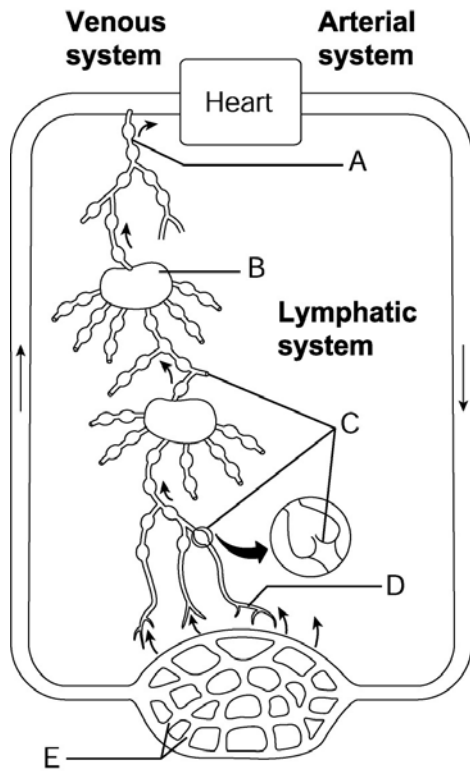

Figure 12.1

Using Figure 12.1, identify the following:

56) The lymph duct is indicated by letter \_\_\_\_\_.

56) \_\_\_\_\_

Fill in the blank or provide a short answer:

57) The role of the \_\_\_\_\_ in the lymphatic system is to remove worn-out blood cells and return some of the products to the liver.

57) \_\_\_\_\_

58) The process by which WBCs and phagocytes migrate to an area experiencing acute inflammation is called \_\_\_\_\_.

58) \_\_\_\_\_

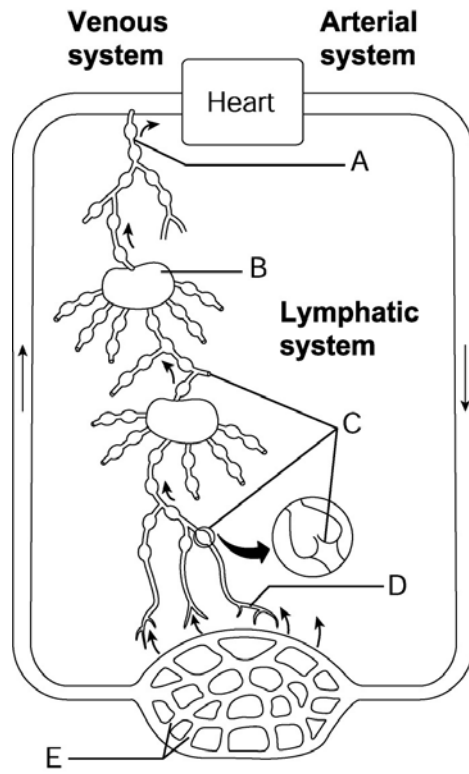

Figure 12.1

Using Figure 12.1, identify the following:

59) A lymph capillary is indicated by letter \_\_\_\_\_.

59) \_\_\_\_\_

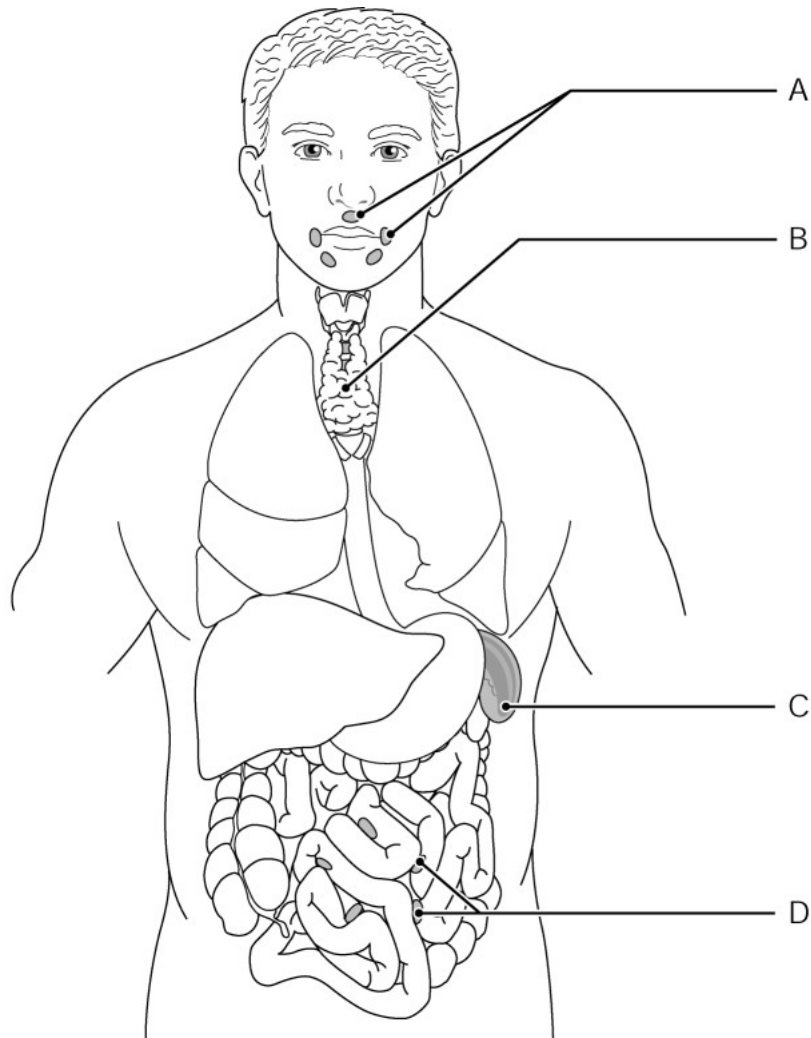

Figure 12.2

*Using Figure 12.2, identify the following:*

60) The thymus gland is indicated by letter \_\_\_\_\_.

60) \_\_\_\_\_

*Fill in the blank or provide a short answer:*

61) Killer T cells, which kill virus-invaded body cells, are also called \_\_\_\_\_.

61) \_\_\_\_\_

62) When an antigen binds to B cell surface receptors, it becomes sensitized (activated) and undergoes \_\_\_\_\_.

62) \_\_\_\_\_

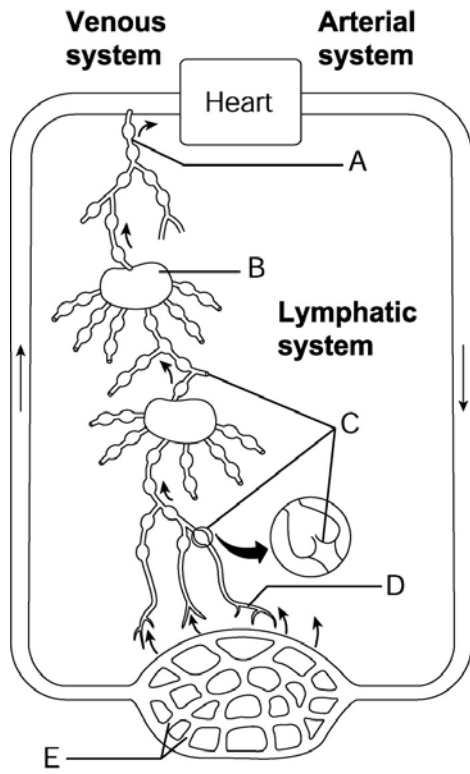

Figure 12.1

Using Figure 12.1, identify the following:

63) Blood capillaries are indicated by letter \_\_\_\_\_.

63) \_\_\_\_\_

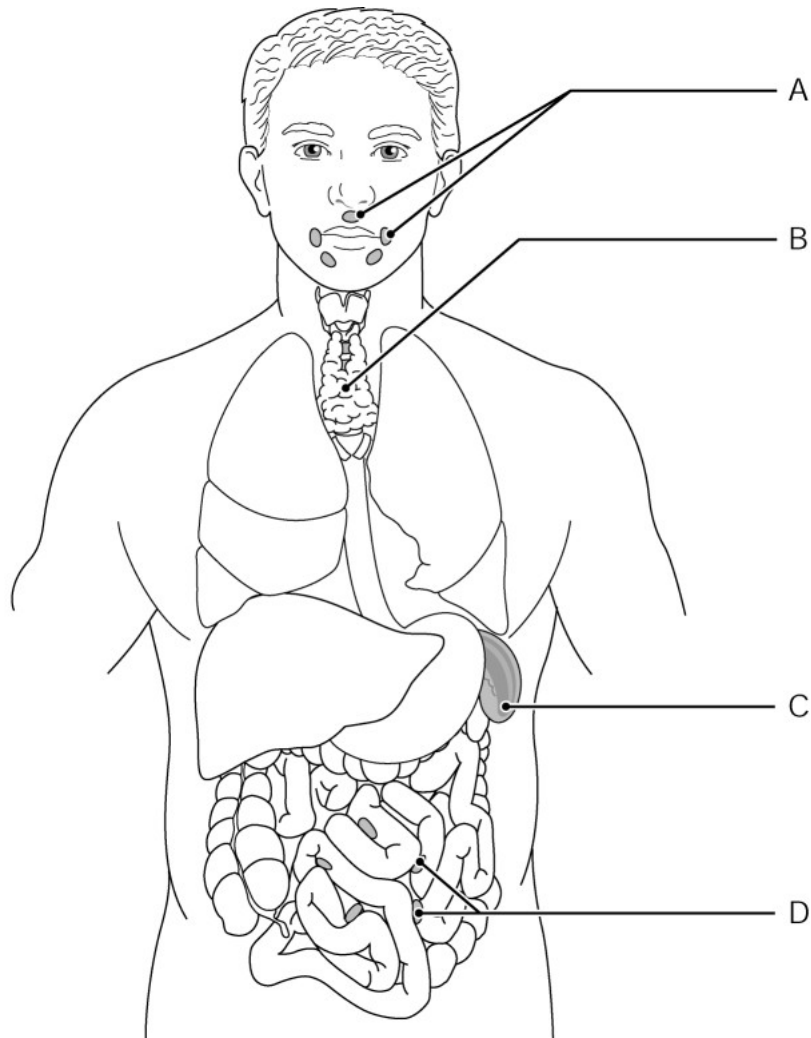

Figure 12.2

*Using Figure 12.2, identify the following:*

64) The lymphoid organ that destroys worn-out blood cells is indicated by letter \_\_\_\_\_.

*Fill in the blank or provide a short answer:*

65) The binding of complement proteins to certain sugar or proteins on a foreign cell's surface is called \_\_\_\_\_.

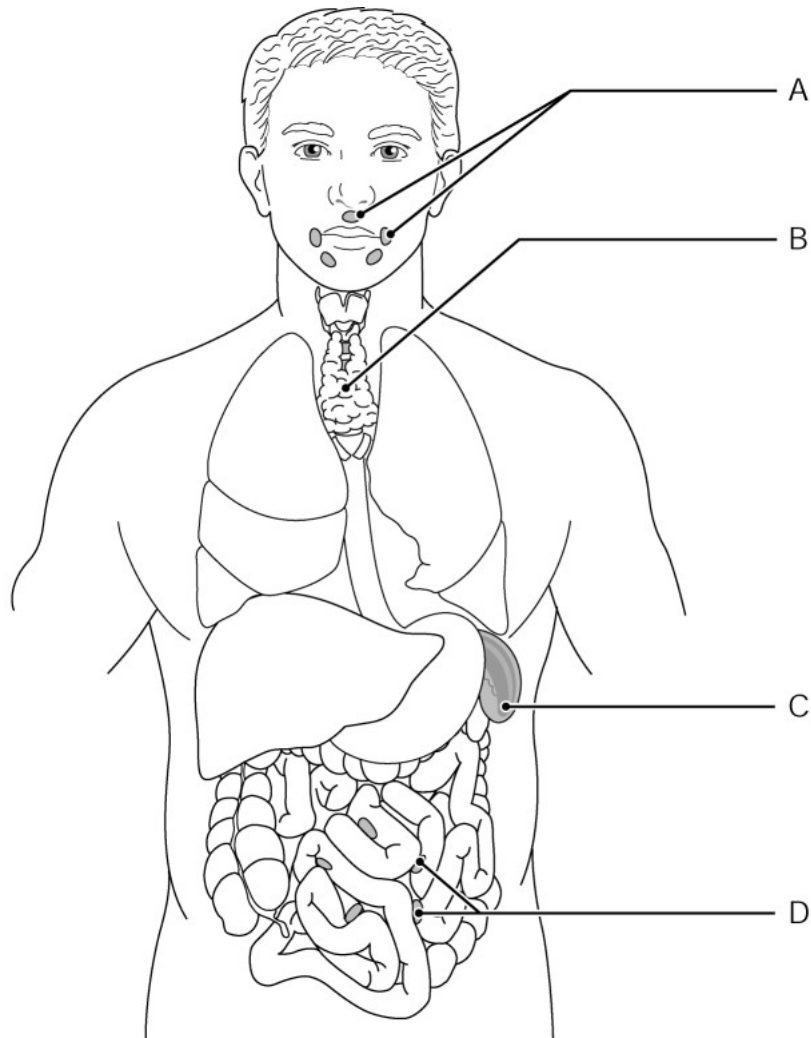

Figure 12.2

*Using Figure 12.2, identify the following:*

66) The tonsils are indicated by letter \_\_\_\_\_.

66) \_\_\_\_\_

*Fill in the blank or provide a short answer:*

67) Excess accumulations of fluid, which impair the exchange of materials within the tissues, is called \_\_\_\_\_.

67) \_\_\_\_\_

68) When B cells encounter antigens and produce antibodies against them, we exhibit \_\_\_\_\_.

68) \_\_\_\_\_

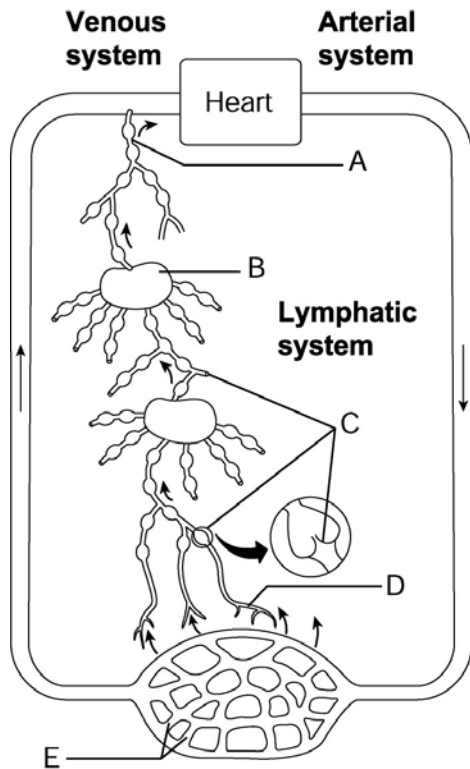

Figure 12.1

Using Figure 12.1, identify the following:

69) A lymph node is indicated by letter \_\_\_\_\_.

69) \_\_\_\_\_

Fill in the blank or provide a short answer:

70) Lymph fluid and some plasma proteins originate (escape) from the \_\_\_\_\_.

70) \_\_\_\_\_

71) The five major immunoglobulin classes are \_\_\_\_\_.

71) \_\_\_\_\_

72) The process by which neutrophils squeeze through capillary walls is called \_\_\_\_\_.

72) \_\_\_\_\_

73) The binding of antibodies to specific sites on bacterial exotoxins or viruses is called \_\_\_\_\_.

73) \_\_\_\_\_

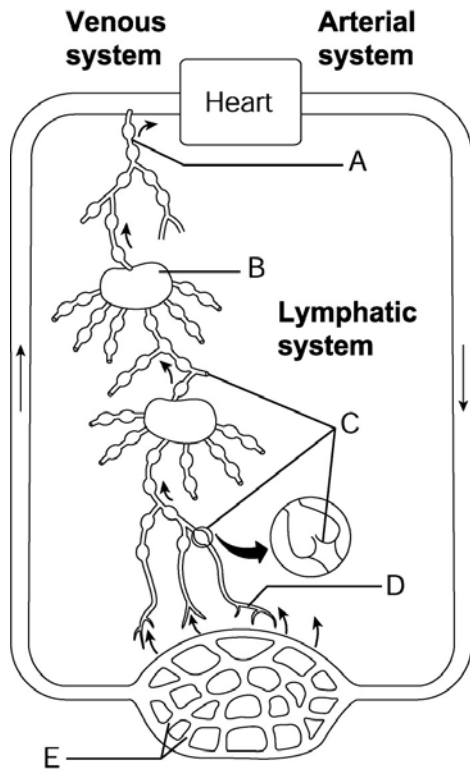

Figure 12.1

Using Figure 12.1, identify the following:

74) Lymphatic collecting vessels are indicated by letter \_\_\_\_\_.

74) \_\_\_\_\_

Fill in the blank or provide a short answer:

75) Harmful or disease-causing microorganisms from which nonspecific defenses protect the body are called \_\_\_\_\_.

75) \_\_\_\_\_

76) Lymph exits the lymph node via the \_\_\_\_\_ vessels.

76) \_\_\_\_\_

77) AIDS cripples the immune system by interfering with the activity of cells called \_\_\_\_\_.

77) \_\_\_\_\_



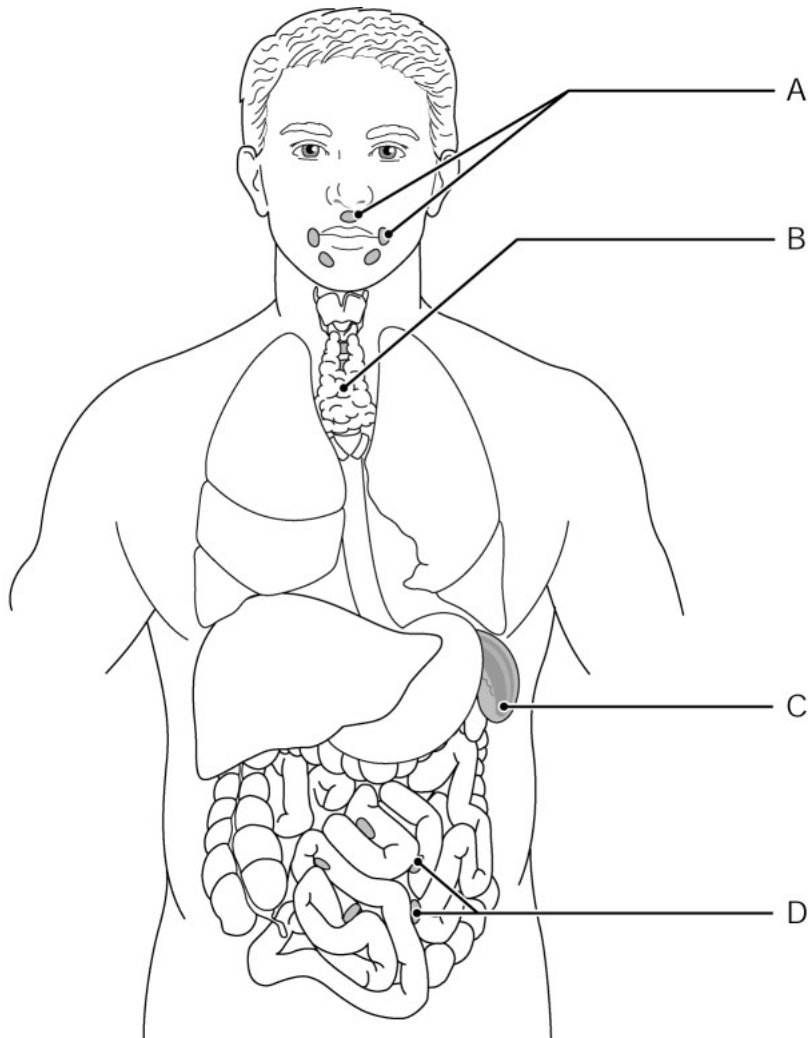

Figure 12.2

*Using Figure 12.2, identify the following:*

78) The lymphoid tissues that trap and remove bacteria that enter the throat are indicated by letter \_\_\_\_\_ 78) \_\_\_\_\_  
 letter \_\_\_\_\_.

*Fill in the blank or provide a short answer:*

79) One effect of complement fixation that causes the cell membranes of foreign cells to become sticky so that they are easier to phagocytize is called \_\_\_\_\_ 79) \_\_\_\_\_

80) A tropical disease that results when parasitic worms clog the lymphatic vessels is called \_\_\_\_\_ 80) \_\_\_\_\_

81) The clumping of foreign cells, a type of antigen-antibody reaction, is called \_\_\_\_\_ 81) \_\_\_\_\_

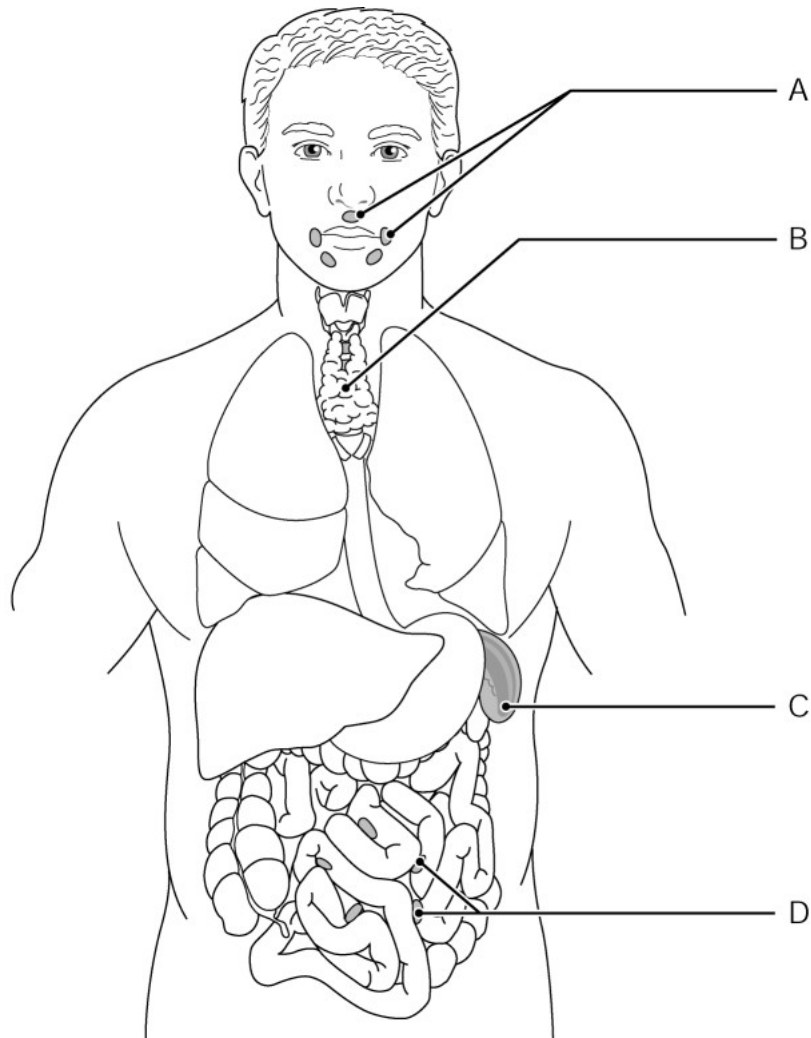

Figure 12.2

Using Figure 12.2, identify the following:

82) The spleen is indicated by letter \_\_\_\_\_.

82) \_\_\_\_\_

**TRUE/FALSE. Write 'T' if the statement is true and 'F' if the statement is false.**

83) The final disposal of cell debris as inflammation subsides is performed by neutrophils.

83) \_\_\_\_\_

84) The thymus gland, found around the trachea, programs certain lymphocytes.

84) \_\_\_\_\_

85) Memory cells are descendants of an activated B or T cell.

85) \_\_\_\_\_

86) The nonspecific defense by which complement proteins attach to sugars or proteins on the surface of foreign cells is called *complement fixation*.

86) \_\_\_\_\_

87) Lymph in the right arm is returned to the heart via the right lymphatic duct.

87) \_\_\_\_\_

88) Fever is a systemic response triggered by pyrogens.

88) \_\_\_\_\_

89) Allografts are tissue grafts taken from an unrelated person.

89) \_\_\_\_\_

90) Like all blood cells, lymphocytes originate from hemocytoblasts contained within red bone marrow.

90) \_\_\_\_\_

- 91) The process that occurs when antibodies clump foreign cells is called agglutination. 91) \_\_\_\_\_
- 92) Antibodies are also referred to as immunoglobulins. 92) \_\_\_\_\_
- 93) Our immune system can be affected by severe stress. 93) \_\_\_\_\_
- 94) Artificially acquired passive immunity is conferred when one receives immune serum for poisonous snake bites. 94) \_\_\_\_\_
- 95) Extremely weakened pathogens that are still alive are attenuated. 95) \_\_\_\_\_
- 96) The tonsils, spleen, thymus gland, and Peyer's patches are referred to as mucosa-associated lymphatic tissue (MALT). 96) \_\_\_\_\_
- 97) The antibody a mother passes to her fetus is IgM. 97) \_\_\_\_\_
- 98) Chemicals secreted by white blood cells and macrophages exposed to foreign substances that can increase body temperature are called *pyrogens*. 98) \_\_\_\_\_
- 99) Tissue grafts harvested from an unrelated person are called *xenografts*. 99) \_\_\_\_\_
- 100) An antibody is a substance capable of provoking an immune response. 100) \_\_\_\_\_
- 101) Allergies, or hypersensitivities, are normal immune responses. 101) \_\_\_\_\_
- 102) Autoimmune diseases occur when the immune system loses its ability to tolerate self-antigens while still recognizing and attaching foreign antigens. 102) \_\_\_\_\_
- 103) The daughter cells of B cells, called plasma cells, release antibodies. 103) \_\_\_\_\_
- 104) Natural killers are unique phagocytic defense cells that can kill cancer cells and virus-infected body cells well before the immune system is activated. 104) \_\_\_\_\_
- 105) The flaplike minivalves of the lymph capillaries act like one-way swinging doors that allow lymph fluid to enter the lymph capillaries but not exit. 105) \_\_\_\_\_
- 106) Macrophages arise from monocytes formed within the bone marrow. 106) \_\_\_\_\_
- 107) Some pathologists consider limitation of joint movement to be an additional fifth cardinal sign of inflammation. 107) \_\_\_\_\_
- 108) There are three major immunoglobulin classes: IgM, IgA, and IgD. 108) \_\_\_\_\_

**MATCHING. Choose the item in column 2 that best matches each item in column 1.**

Match the following protective mechanism with its associated element:

- |  |                              |            |
|--|------------------------------|------------|
| 109) Propels debris-laden mucus away from lower respiratory passages | A) gastric juice             | 109) _____ |
|  | B) lacrimal secretions       |            |
| 110) Contains lysozyme   | C) nasal hairs               | 110) _____ |
| 111) Inhibits growth of bacteria and fungi                           | in female reproductive tract | 111) _____ |

- \_\_\_\_\_
- 112) Traps microorganisms in respiratory and digestive tracts
- D) keratin  
E) acid mantle  
F) cilia  
G) mucus
- 112) \_\_\_\_\_

*Match the following biological function with its antibody class:*

- 113) First immunoglobulin class released to plasma by plasma cells during primary response
- A) IgM
- 113) \_\_\_\_\_

*Match the following descriptions with the appropriate lymphoid organ or tissue:*

- 114) Located overlying the heart
- A) thymus gland
- 114) \_\_\_\_\_
- 115) Trap and remove bacteria and pathogens entering the throat
- B) tonsils
- 115) \_\_\_\_\_

*Match the following biological function with its antibody class:*

- 116) Potent agglutinating agent
- A) IgD
- 116) \_\_\_\_\_
- 117) Believed to be cell surface receptor of immunocompetent B cell
- B) IgM
- 117) \_\_\_\_\_

*Match the following descriptions with the appropriate lymphoid organ or tissue:*

- 118) Located in the pharynx (throat)
- A) spleen
- 118) \_\_\_\_\_
- 119) Located on the left side of the abdominal cavity
- B) tonsils
- 119) \_\_\_\_\_
- 120) Filters and cleanses the blood of bacteria, viruses, and other debris
- 120) \_\_\_\_\_

*Match the following protective mechanism with its associated element:*

- 121) Filters and traps microorganisms within inhaled air
- A) mucus
- 121) \_\_\_\_\_
- B) nasal hairs

*Match the following biological function with its antibody class:*

- 122) Crosses placenta and provides passive immunity to fetus
- A) IgA
- 122) \_\_\_\_\_
- B) IgG

123) Bathes and protects mucosal surfaces from attachment of pathogens 123) \_\_\_\_\_

*Match the following protective mechanism with its associated element:*

124) Contains concentrated hydrochloric acid and protein-digested enzymes that destroy pathogens within the stomach 124) \_\_\_\_\_

A) acid mantle

B) gastric juice

*Match the following descriptions with the appropriate lymphoid organ or tissue:*

125) Located in the wall of the small intestines 125) \_\_\_\_\_

A) Peyer's patches

*Match the following biological function with its antibody class:*

126) Main antibody of primary and secondary responses 126) \_\_\_\_\_

A) IgG

*Match the following protective mechanism with its associated element:*

127) Provides resistance against acids, alkalis, and bacterial enzymes 127) \_\_\_\_\_

A) gastric juice

B) keratin

*Match the following biological function with its antibody class:*

128) Triggers the release of histamine 128) \_\_\_\_\_

A) IgE

**ESSAY. Write your answer in the space provided or on a separate sheet of paper.**

129) Describe several of the protective chemicals produced by the skin and mucous membranes.

130) Describe the four major types of transplant grafts.

131) Explain three current theories that attempt to explain why self-tolerance breaks down in autoimmune disorders.

132) Describe the methods the body uses to help return lymph to the heart.

133) List and describe the cells and chemicals the body uses as its second line of defense.

134) Explain the origin and pathway of lymph.

135) Identify the four most common indicators and major symptoms of an acute inflammatory response and explain their origins.

- 1) D
- 2) B
- 3) E
- 4) A
- 5) C
- 6) A
- 7) E
- 8) A
- 9) D
- 10) C
- 11) D
- 12) E
- 13) A
- 14) E
- 15) B
- 16) E
- 17) B
- 18) A
- 19) B
- 20) C
- 21) A
- 22) E
- 23) D
- 24) B
- 25) A
- 26) B
- 27) B
- 28) D
- 29) A
- 30) D
- 31) D
- 32) C
- 33) B
- 34) B
- 35) E
- 36) B
- 37) A
- 38) E
- 39) C
- 40) E
- 41) E
- 42) D
- 43) D
- 44) A
- 45) C
- 46) A
- 47) E
- 48) immunoglobulins
- 49) allergens or hypersensitivities
- 50) anaphylactic shock
- 51) self-antigens (autoantigens)

- 52) trabeculae
- 53) D
- 54) haptens
- 55) MALT (mucosa-associated lymphatic tissue)
- 56) A
- 57) spleen
- 58) chemotaxis
- 59) D
- 60) B
- 61) cytotoxic T cells
- 62) clonal selection
- 63) E
- 64) C
- 65) complement fixation
- 66) A
- 67) edema
- 68) active immunity
- 69) B
- 70) blood plasma
- 71) IgM, IgA, IgD, IgG, IgE
- 72) diapedesis
- 73) neutralization
- 74) C
- 75) pathogens
- 76) efferent lymphatic
- 77) helper T cells
- 78) A
- 79) opsonization
- 80) elephantiasis
- 81) agglutination
- 82) C
- 83) FALSE
- 84) FALSE
- 85) TRUE
- 86) TRUE
- 87) TRUE
- 88) TRUE
- 89) TRUE
- 90) TRUE
- 91) TRUE
- 92) TRUE
- 93) TRUE
- 94) TRUE
- 95) TRUE
- 96) FALSE
- 97) FALSE
- 98) TRUE
- 99) FALSE
- 100) FALSE
- 101) FALSE
- 102) TRUE
- 103) TRUE

- 104) FALSE  
105) TRUE  
106) TRUE  
107) TRUE  
108) FALSE  
109) F  
110) B  
111) E  
112) G  
113) A  
114) A  
115) B  
116) B  
117) A  
118) B  
119) A  
120) A  
121) B  
122) B  
123) A  
124) B  
125) A  
126) A  
127) B  
128) A  
129) Skin produces acid secretions that inhibit bacterial growth, and sebum contains chemicals that are toxic to bacteria. Vaginal secretions are highly acidic. The stomach mucosa secretes hydrochloric acid and protein-digesting enzymes, both of which can kill pathogens. Saliva and tears contain lysozyme, an enzyme that destroys bacteria. Mucus is a sticky mucous membrane secretion that traps microorganisms.  
130) Autografts are tissue grafts transplanted from one site to another within the same person. Isografts are tissue grafts harvested from a genetically identical person (identical twin). Allografts are tissue grafts harvested from an unrelated person. Xenografts are tissue grafts harvested from different animal species.  
131) Inefficient lymphocyte programming is one theory that suggests self-reactive B or T cells escape to the rest of the body. Another theory is that self-proteins appear within the circulation that were not previously exposed to the immune system, thus initiating an immune response. These "hidden" antigens are found in sperm cells, the eye lens, and thyroid proteins. Another theory is that antibodies produced against foreign antigens cross-react with self-antigens such as when streptococcal bacteria cross-react with heart antigens causing rheumatic fever.  
132) The return of lymph to the heart is aided by: 1. the milking action of the skeletal muscles, 2. pressure changes in the thorax during breathing, 3. smooth muscles in the walls of the larger lymphatics contract rhythmically.  
133) 1. Phagocytes, such as neutrophils or macrophages, engulf foreign particles. These cells are in nearly every body organ and confront pathogens that make it through the surface membrane barriers.  
2. Natural killer cells, found in blood and lymph, are lymphocytes. They can lyse and kill cancer cells and virus-infected body cells.  
3. The inflammatory response is a nonspecific response that occurs when body tissues are injured.  
134) Lymph fluid arises from blood plasma that has been forced out of the capillary beds by osmotic and hydrostatic pressures. The fluid left behind is called interstitial fluid. The interstitial fluid is then picked up by lymph capillaries, after which it is called *lymph*. Lymph is routed up the lymphatic vessels until it is finally returned to the venous system through either the right lymphatic duct or the thoracic duct.  
135) The four most common indicators of the inflammatory response are redness, heat, swelling, and pain. Redness and heat are a result of dilation of blood vessels that increase blood flow to the injured area. Swelling occurs when increased permeability of the capillaries allows plasma to leak from the bloodstream into the tissue spaces. The excess fluid, or edema, triggers the activation of pain receptors in the area, accounting for the pain associated with



an  
injur  
y.

Exam

Name \_\_\_\_\_

**MULTIPLE CHOICE. Choose the one alternative that best completes the statement or answers the question.**

- 1) The serous membrane covering the surface of the lungs is called the: 1) \_\_\_\_\_
  - A) pleurisy
  - B) mediastinum
  - C) visceral pleura
  - D) parietal pleura
  - E) main (primary) bronchi
  
- 2) The bluish cast that results from inadequate oxygenation of the skin and mucosa is called: 2) \_\_\_\_\_
  - A) albinism
  - B) xanthosis
  - C) melanosis
  - D) cyanosis
  - E) erythema
  
- 3) The lipid molecule critical to lung function that coats the gas-exposed alveolar surfaces is called: 3) \_\_\_\_\_
  - A) renin
  - B) interferon
  - C) lecithin
  - D) kinin
  - E) surfactant
  
- 4) Cilia of the trachea that beat continually propel contaminated mucus: 4) \_\_\_\_\_
  - A) toward the glottis to be hiccupped out
  - B) toward the lungs to be encapsulated
  - C) toward the nose to be sneezed out
  - D) toward the epiglottis to be coughed out
  - E) toward the throat to be swallowed or spat out
  
- 5) Which one of the following is NOT a function of the paranasal sinuses: 5) \_\_\_\_\_
  - A) they are olfactory receptors for smell
  - B) they produce mucus
  - C) they lighten the skull
  - D) they act as resonance chambers for speech
  - E) they help to moisten air
  
- 6) The respiratory conducting passageways perform all of the following functions EXCEPT: 6) \_\_\_\_\_
  - A) purify air
  - B) warm incoming air
  - C) humidify air
  - D) exchange gases
  - E) allow air to reach the lungs
  
- 7) Which one of the following is NOT a factor influencing respiratory rate and depth: 7) \_\_\_\_\_
  - A) levels of oxygen and carbon dioxide
  - B) volition
  - C) physical exercise
  - D) enzymatic factors
  - E) emotional factors
  
- 8) The most important chemical stimuli leading to increased rate and depth of breathing is: 8) \_\_\_\_\_
  - A) decreased carbon dioxide in the blood
  - B) increased blood pH
  - C) increased hydrogen ion in the blood
  - D) increased carbon dioxide in the blood
  - E) decreased oxygen level in the blood

- 9) What is the role of mucus in the nasal cavity: 9) \_\_\_\_\_  
A) trap incoming bacteria and other foreign debris  
B) lighten the skull  
C) act as a resonance chamber for speech  
D) increase the air turbulence in the nasal cavity  
E) separate the oral from the nasal cavity
- 10) The homeostatic imbalance associated with the death of many full-term newborn infants is called: 10) \_\_\_\_\_  
A) CTRL            B) COPD            C) CF            D) SIDS            E) IRDS
- 11) Which one of the following terms does not apply to the nose: 11) \_\_\_\_\_  
A) nasal septum  
B) nasal cavity  
C) external nares  
D) nasopharynx  
E) nostrils
- 12) The gas exchange that occurs between blood and tissue cells at systemic capillaries is called: 12) \_\_\_\_\_  
A) pulmonary ventilation  
B) internal respiration  
C) expiration  
D) external respiration  
E) respiratory gas transport
- 13) Which one of the following bones does NOT contain paranasal sinuses: 13) \_\_\_\_\_  
A) ethmoid            B) frontal            C) maxilla            D) mandible            E) sphenoid
- 14) A very deep inspiration that ventilates all alveoli is: 14) \_\_\_\_\_  
A) crying  
B) sneezing  
C) hiccupping  
D) coughing  
E) yawning
- 15) Which of the following are currently the most damaging and disabling respiratory diseases in the U.S.: 15) \_\_\_\_\_  
A) lung cancer and asthma  
B) COPD and lung cancer  
C) tuberculosis and pneumonia  
D) tuberculosis and COPD  
E) asthma and tuberculosis
- 16) Hypoventilation dramatically increases carbonic acid concentration and involves: 16) \_\_\_\_\_  
A) extremely slow breathing  
B) extremely fast breathing  
C) extremely deep breathing  
D) intermittent breathing  
E) irregular breathing
- 17) The flap of elastic cartilage that protects food from entering the larynx when swallowing is the: 17) \_\_\_\_\_  
A) thyroid cartilage

- B) Adam's apple
- C) epiglottis
- D) glottis
- E) trachea

- 18) The respiratory rate in adults is: 18) \_\_\_\_\_
- A) 20-25 respirations per minute
  - B) over 40 respirations per minute
  - C) 12-18 respirations per minute
  - D) 30 respirations per minute
  - E) 5-10 respirations per minute
- 19) Air moving in and out of the lungs is called: 19) \_\_\_\_\_
- A) external respiration
  - B) expiration
  - C) inspiration
  - D) internal respiration
  - E) pulmonary ventilation
- 20) In order to inspire: 20) \_\_\_\_\_
- A) the external intercostal muscles relax
  - B) the intrapulmonary volume must decrease
  - C) the intrapulmonary volume must increase
  - D) the diaphragm relaxes
  - E) gas pressure in the lungs must increase
- 21) Emphysema results in all of the following EXCEPT: 21) \_\_\_\_\_
- A) expanded barrel chest
  - B) moon face
  - C) decreased lung elasticity
  - D) enlarged alveoli
  - E) lung fibrosis
- 22) Vibration due to exhaled air that results in speech is a function of the: 22) \_\_\_\_\_
- A) complete voice box
  - B) true vocal cords
  - C) glottis
  - D) epiglottis
  - E) false vocal cords
- 23) When oxygen enters the respiratory system, what is the next structure to which it travels immediately upon leaving the trachea: 23) \_\_\_\_\_
- A) tertiary bronchi
  - B) main (primary) bronchi
  - C) bronchioles
  - D) pleura
  - E) alveoli
- 24) The respiratory movement representing the total amount of exchangeable air is the: 24) \_\_\_\_\_
- A) inspiratory reserve volume
  - B) expiratory reserve volume
  - C) vital capacity

D) dead space volume

E) tidal volume

- 25) Following the removal of the larynx, a person would be unable to: 25) \_\_\_\_\_  
A) sneeze                      B) hear                      C) eat                      D) speak                      E) breathe
- 26) Cessation of breathing is called: 26) \_\_\_\_\_  
A) tachypnea  
B) apnea  
C) eupnea  
D) hyperpnea  
E) dyspnea
- 27) Oxygen binds with hemoglobin in the blood to form: 27) \_\_\_\_\_  
A) plasma  
B) carbon dioxide  
C) oxyhemoglobin  
D) carbonic acid  
E) bicarbonate ion
- 28) Which one of the following is NOT true of the lungs: 28) \_\_\_\_\_  
A) the narrower portion of each lung is called the apex  
B) the bases rest on the diaphragm  
C) the right lung has three lobes  
D) both lungs have two lobes  
E) the left lung has two lobes
- 29) Exchange of both oxygen and carbon dioxide through the respiratory membrane occurs by: 29) \_\_\_\_\_  
A) active transport  
B) simple diffusion  
C) facilitated diffusion  
D) passive transport  
E) osmosis
- 30) Which one of the following is NOT true of lung cancer: 30) \_\_\_\_\_  
A) it is generally more prevalent in males than females  
B) it accounts for one-third of all cancer deaths in the U.S.  
C) most types of lung cancer are very aggressive  
D) lung cancers often metastasize rapidly and widely  
E) its incidence is currently increasing
- 31) Hyperventilation leads to all of the following EXCEPT: 31) \_\_\_\_\_  
A) dizziness  
B) buildup of carbon dioxide in the blood  
C) cyanosis  
D) brief periods of apnea  
E) fainting
- 32) An emotionally-induced response during which air movement is similar to crying is: 32) \_\_\_\_\_  
A) laughing  
B) sneezing  
C) hiccupping

- D) yawning
- E) coughing

- 33) Surfactant is usually present in fetal lungs in adequate quantities by: 33) \_\_\_\_\_
- A) 20–22 weeks of pregnancy
  - B) 28–30 weeks of pregnancy
  - C) 22–24 weeks of pregnancy
  - D) 26–28 weeks of pregnancy
  - E) 24–26 weeks of pregnancy
- 34) Which one of the following is NOT true of cystic fibrosis: 34) \_\_\_\_\_
- A) it causes oversecretion of thick mucus that clogs the respiratory passages
  - B) it is the most common lethal genetic disease in the U.S.
  - C) it causes sweat glands to produce an extremely salty perspiration
  - D) it impairs food digestion
  - E) it is rarely fatal
- 35) The amount of air exchanged during normal quiet breathing is about: 35) \_\_\_\_\_
- A) 1200 mL      B) 2100 mL      C) 6000 mL      D) 500 mL      E) 4800 mL
- 36) The opening between the vocal cords is called the: 36) \_\_\_\_\_
- A) larynx
  - B) epiglottis
  - C) glottis
  - D) thyroid cartilage
  - E) esophagus
- 37) The nasal cavity is separated from the oral cavity by: 37) \_\_\_\_\_
- A) the nasal conchae
  - B) both the hard and soft palate
  - C) the hard palate
  - D) both the nasal conchae and hard palate
  - E) the soft palate
- 38) Obstruction of the trachea by a piece of food can lead to: 38) \_\_\_\_\_
- A) pleurisy
  - B) aspiration pneumonia
  - C) pulmonary tamponade
  - D) hemothorax
  - E) pneumothorax
- 39) Which one of the following structures is NOT part of the respiratory zone: 39) \_\_\_\_\_
- A) alveoli
  - B) respiratory bronchioles
  - C) primary bronchi
  - D) alveolar sacs
  - E) alveolar ducts
- 40) The walls of the alveoli are composed largely of: 40) \_\_\_\_\_
- A) stratified cuboidal epithelium
  - B) simple cuboidal epithelium
  - C) stratified squamous epithelium

- D) pseudostratified epithelium
- E) simple squamous epithelium

- 41) The pharyngotympanic tubes, which drain the middle ear, open into the: 41) \_\_\_\_\_  
A) nasopharynx  
B) laryngopharynx  
C) palatopharynx  
D) oropharynx  
E) tracheopharynx
- 42) The conducting passageways of the respiratory system include all of the following structures EXCEPT: 42) \_\_\_\_\_  
A) nose                      B) larynx                      C) alveoli                      D) trachea                      E) pharynx
- 43) Which one of the following is NOT a feature of COPD: 43) \_\_\_\_\_  
A) most patients have a genetic predisposition to COPD  
B) most COPD victims are hypoxic  
C) dyspnea becomes progressively more severe  
D) frequent pulmonary infections are common  
E) most patients have a history of smoking
- 44) The abbreviation IRDS stands for: 44) \_\_\_\_\_  
A) intermittent respiratory distress state  
B) infant respiratory disease syndrome  
C) intermittent respiratory disease syndrome  
D) infant respiratory disease state  
E) infant respiratory distress syndrome
- 45) Tonsils that lie at the base of the tongue are called: 45) \_\_\_\_\_  
A) pharyngotympanic tonsils  
B) lingual tonsils  
C) pharyngeal tonsils  
D) palatine tonsils  
E) adenoids
- 46) The molecule that prevents lung collapse by lowering the surface tension of the water film lining each alveolar sac is called: 46) \_\_\_\_\_  
A) fibrosin                      B) renin                      C) surfactant                      D) lecithin                      E) resorbin
- 47) The amount of air that can be forcibly exhaled after a tidal expiration is about: 47) \_\_\_\_\_  
A) 6000 mL                      B) 2100 mL                      C) 500 mL                      D) 4800 mL                      E) 1200 mL
- 48) Which one of the following is NOT true of inspiration: 48) \_\_\_\_\_  
A) relaxation of the external intercostal muscles helps increase the size of the thoracic cavity  
B) the decreased gas pressure produces a partial vacuum that forcibly sucks air in  
C) increased intrapulmonary volume causes inhaled gases to spread out  
D) contraction of the diaphragm muscle helps increase the size of the thoracic cavity  
E) air continues to move into the lungs until intrapulmonary pressure equals atmospheric pressure
- 49) Air from the nasal cavity enters the superior portion of the pharynx called the: 49) \_\_\_\_\_  
A) oropharynx

- B) palatopharynx
- C) nasopharynx
- D) tracheopharynx
- E) laryngopharynx

50) Most carbon dioxide is transported within blood plasma as:

50) \_\_\_\_\_

- A) oxyhemoglobin
- B) carbonic acid
- C) bicarbonate ion
- D) hydrogen ion
- E) carbohemoglobin

**SHORT ANSWER. Write the word or phrase that best completes each statement or answers the question.**

*Fill in the blank or provide a short answer:*

51) The large shield-shaped thyroid cartilage that protrudes anteriorly is commonly called the \_\_\_\_\_.

51) \_\_\_\_\_

52) Normal quiet breathing moves about \_\_\_\_\_ mL of air into and out of the lungs with each breath.

52) \_\_\_\_\_

53) Air that remains in the conducting zone passageways and never reaches the alveoli is called the \_\_\_\_\_.

53) \_\_\_\_\_

54) Most carbon dioxide is dissolved in blood plasma and transported as \_\_\_\_\_.

54) \_\_\_\_\_

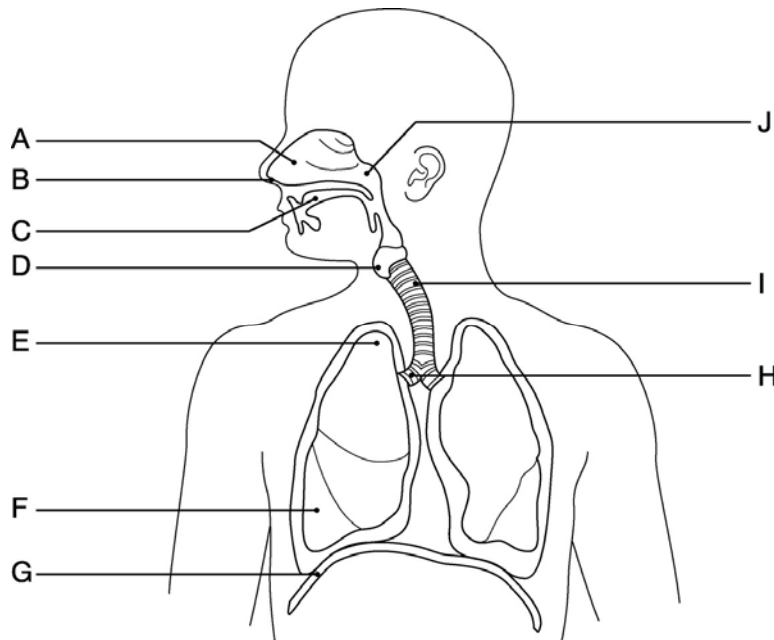

Figure 13.1

*Using Figure 13.1, identify the following:*

55) The trachea is indicated by letter \_\_\_\_\_.

55) \_\_\_\_\_

56) The pharynx is indicated by letter \_\_\_\_\_.

56) \_\_\_\_\_

57) The oral cavity is indicated by letter \_\_\_\_\_.

57) \_\_\_\_\_

58) The most important stimulus for breathing in a healthy person is the body's need to rid

itself of the blood



gas 58)  
called \_\_\_\_\_  
\_\_\_\_\_.

\_\_\_\_\_  
\_\_\_\_\_  
\_\_\_\_\_  
\_\_\_\_\_  
-

Fill in the blank or provide a short answer:

59) The presence of air in the intrapleural space is known as \_\_\_\_\_. 59) \_\_\_\_\_

60) Enlargement of the alveoli and chronic inflammation of the lungs are characteristics of a respiratory disease called \_\_\_\_\_. 60) \_\_\_\_\_

Fill in the blank or provide a short answer:

61) The mucosa-lined windpipe that extends from the larynx to the level of the fifth thoracic vertebra is called the \_\_\_\_\_. 61) \_\_\_\_\_

62) The process of moving air into and out of the lungs is commonly called breathing or \_\_\_\_\_. 62) \_\_\_\_\_

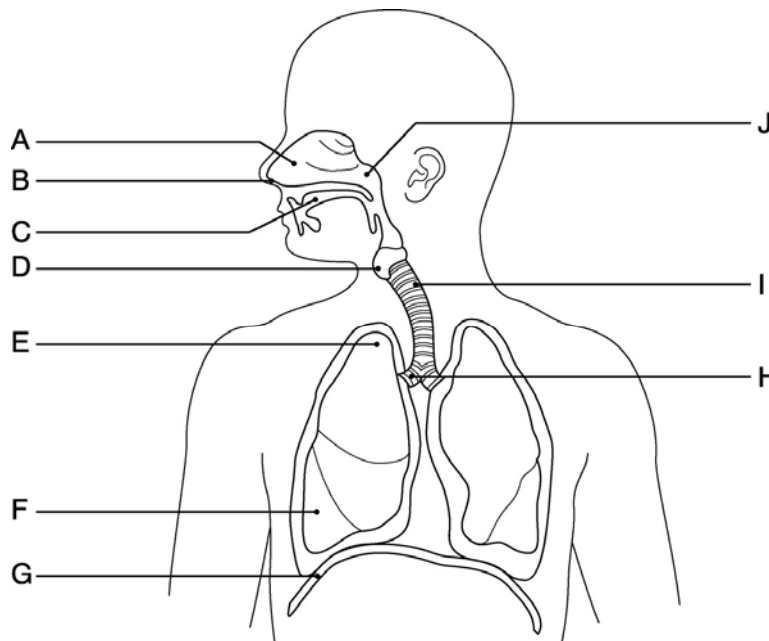

Figure 13.1

Using Figure 13.1, identify the following:

63) The nostrils are indicated by letter \_\_\_\_\_. 63) \_\_\_\_\_

Fill in the blank or provide a short answer:

64) The anterior portion of the palate that is supported by bone is called the \_\_\_\_\_. 64) \_\_\_\_\_

65) A mechanism that clears the upper respiratory passages, which is similar to a cough except that the expelled air is directed through the nasal cavities instead of the oral cavity, is called a \_\_\_\_\_. 65) \_\_\_\_\_

66) Chronically inflamed, hypersensitive bronchial passages that can be irritated by dust mite and cockroach droppings are indicative of \_\_\_\_\_. 66) \_\_\_\_\_

Fill in the blank or provide a short answer:

67) A procedure in which air within the lungs is used to forcibly expel an obstructing piece of food to avoid suffocation is called the \_\_\_\_\_.

67) \_\_\_\_\_

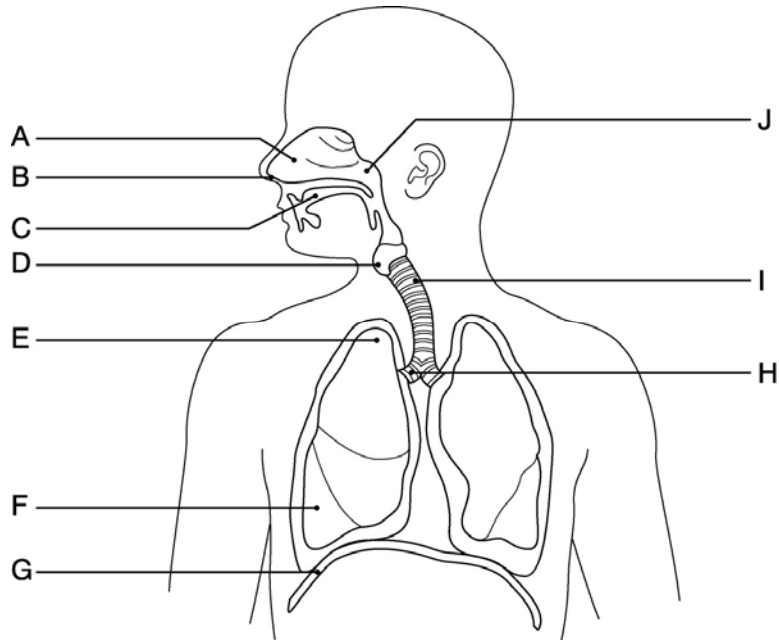

Figure 13.1

Using Figure 13.1, identify the following:

68) The larynx is indicated by letter \_\_\_\_\_.

68) \_\_\_\_\_

Fill in the blank or provide a short answer:

69) "Dust cells" that wander in and out of the alveoli, picking up bacteria, carbon particles, and other debris, are actually \_\_\_\_\_.

69) \_\_\_\_\_

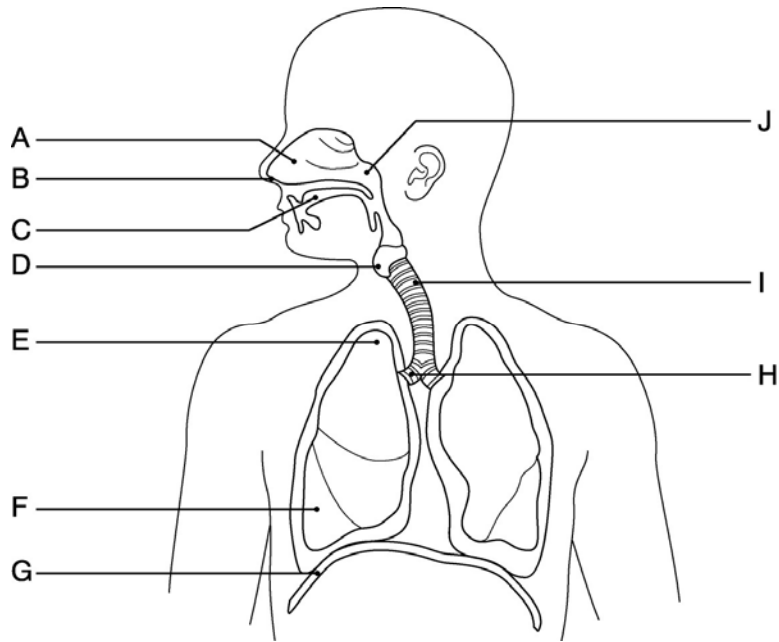

Figure 13.1

Using Figure 13.1, identify the following:

70) The diaphragm muscle is indicated by letter \_\_\_\_\_.

70) \_\_\_\_\_

71) The right primary bronchus is indicated by letter \_\_\_\_\_.

71) \_\_\_\_\_

*Fill in the blank or provide a short answer:*

72) During internal respiration, the blood gas \_\_\_\_\_ is loaded into the bloodstream.

72) \_\_\_\_\_

73) A normal respiratory rate of about 12–15 breaths per minute is called \_\_\_\_\_.

73) \_\_\_\_\_

74) The three mucosa-covered projections into the nasal cavity that greatly increase surface area of mucosa exposed to air are called \_\_\_\_\_.

74) \_\_\_\_\_

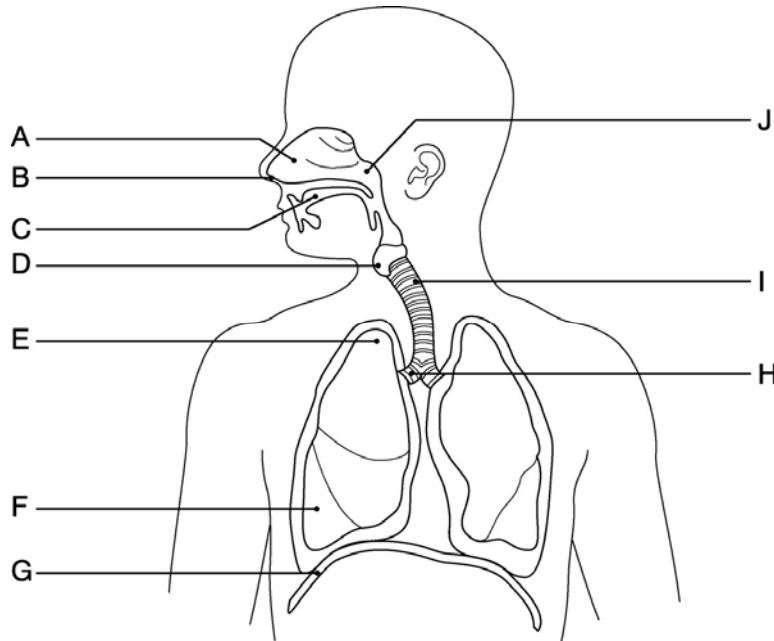

Figure 13.1

*Using Figure 13.1, identify the following:*

75) The nasal cavity is indicated by the letter \_\_\_\_\_.

75) \_\_\_\_\_

*Fill in the blank or provide a short answer:*

76) The tonsils found in the nasopharynx are called \_\_\_\_\_ or \_\_\_\_\_.

76) \_\_\_\_\_

77) The inspiratory muscles that contract so we can inspire air are the \_\_\_\_\_ and \_\_\_\_\_.

77) \_\_\_\_\_

78) Gas exchange between the blood and tissue cells is called \_\_\_\_\_.

78) \_\_\_\_\_

79) The smallest conducting passageways of the lungs are called \_\_\_\_\_.

79) \_\_\_\_\_

80) The air sacs of the lungs are called \_\_\_\_\_.

80) \_\_\_\_\_

81) An abnormal bubbling sound caused by diseased respiratory tissue, mucus, or pus is called \_\_\_\_\_.

81) \_\_\_\_\_

82) Inflammation of the sinuses that can cause marked changes in voice quality is called \_\_\_\_\_.

82) \_\_\_\_\_

83) Oxygen bound to hemoglobin molecules on RBCs is called \_\_\_\_\_.

83) \_\_\_\_\_

84) Respiratory capacities are measured with a \_\_\_\_\_.

84) \_\_\_\_\_

85) The flap of elastic cartilage that protects the opening of the larynx is called the \_\_\_\_\_.

85) \_\_\_\_\_

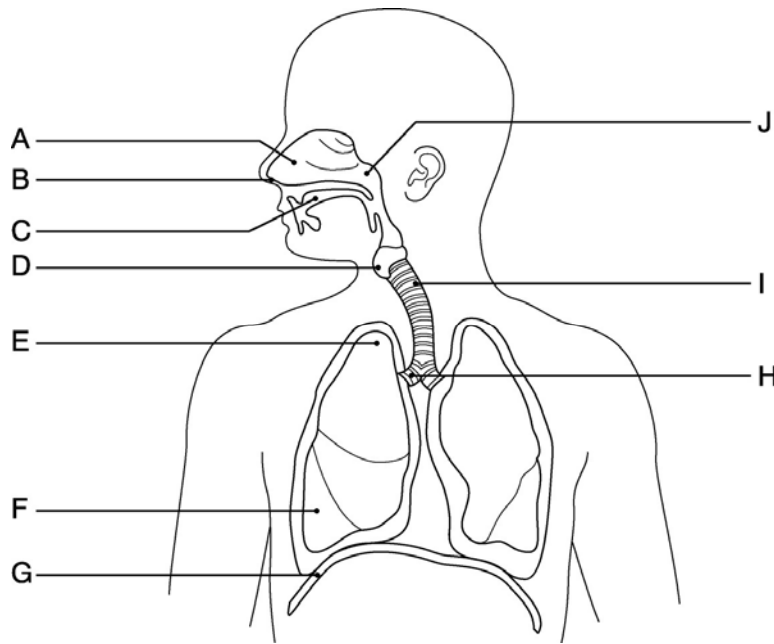

Figure 13.1

Using Figure 13.1, identify the following:

86) The apex of the right lung is indicated by letter \_\_\_\_\_.

86) \_\_\_\_\_

Fill in the blank or provide a short answer:

87) The central area between the two lungs that houses the heart, great blood vessels, bronchi, and esophagus is called the \_\_\_\_\_.

87) \_\_\_\_\_

88) The C-shaped rings that reinforce the trachea are constructed of \_\_\_\_\_ cartilage.

88) \_\_\_\_\_

89) The throat is also known as the \_\_\_\_\_.

89) \_\_\_\_\_

90) The opening between the vocal folds is called the \_\_\_\_\_.

90) \_\_\_\_\_

91) Inadequate oxygen delivery to body tissues is called \_\_\_\_\_.

91) \_\_\_\_\_

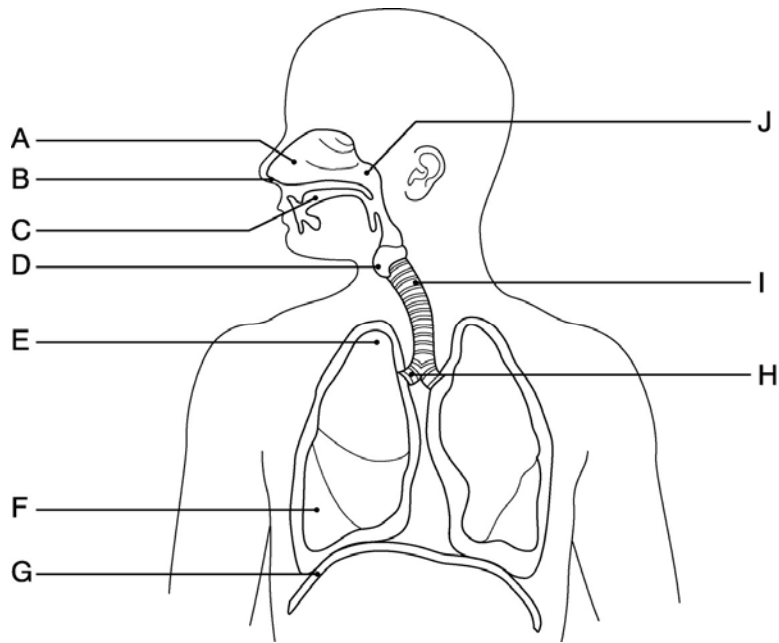

Figure 13.1

Using Figure 13.1, identify the following:

92) The base of the right lung is indicated by letter \_\_\_\_\_.

92) \_\_\_\_\_

**TRUE/FALSE. Write 'T' if the statement is true and 'F' if the statement is false.**

93) Sudden inspirations resulting from spasms of the diaphragm are hiccups.

93) \_\_\_\_\_

94) Inspiration by the diaphragm muscle is regulated by the phrenic nerves.

94) \_\_\_\_\_

95) The process of breathing is known as pulmonary ventilation.

95) \_\_\_\_\_

96) The respiratory membrane is the air-blood barrier, where gases are exchanged.

96) \_\_\_\_\_

97) The respiratory zone includes the respiratory bronchioles, alveolar ducts, alveolar sacs, and alveoli.

97) \_\_\_\_\_

98) The larynx routes air and food into their proper channel and plays an important role in speech production.

98) \_\_\_\_\_

99) According to the laws of diffusion, movement of a respiratory gas occurs toward the area of higher concentration of that particular respiratory gas.

99) \_\_\_\_\_

100) The lungs of the fetus are filled with air late in pregnancy.

100) \_\_\_\_\_

101) The faulty gene associated with cystic fibrosis codes for the CFTR protein, which controls the flow of chloride in and out of cells.

101) \_\_\_\_\_

102) The total amount of exchangeable air in a healthy young male is typically around 4800 mL.

102) \_\_\_\_\_

103) The general term for inadequate oxygen delivery to body tissues regardless of the cause is called hypoxia.

103) \_\_\_\_\_

104) The amount of air that can be forcibly exhaled after a normal tidal expiration is the residual volume.

104) \_\_\_\_\_

- 105) Venous blood in systemic circulation is poorer in oxygen and richer in carbon dioxide. 105) \_\_\_\_
- 106) There are only three paranasal sinuses located in the frontal, sphenoid, and parietal bones. 106) \_\_\_\_
- 107) Inspiration results when the diaphragm and external intercostal muscles relax. 107) \_\_\_\_
- 108) The emergency surgical opening of the trachea is called a tracheostomy. 108) \_\_\_\_
- 109) The pharyngeal tonsils are also known as the adenoids. 109) \_\_\_\_
- 110) The superior portion of the lung is called the base. 110) \_\_\_\_
- 111) Inflammation of the nasal mucosa by cold viruses and various antigens is called rhinitis. 111) \_\_\_\_
- 112) The ciliated cells of the nasal mucosa propel contaminated mucus posteriorly toward the pharynx. 112) \_\_\_\_
- 113) The larynx serves as a passageway for both food and air. 113) \_\_\_\_
- 114) Inflammation of the pleura is often caused by decreased secretion of pleural fluid called pleurisy. 114) \_\_\_\_
- 115) The "guardian of the airways" that prevents food from entering the superior opening of the larynx is the thyroid cartilage. 115) \_\_\_\_
- 116) Expiration occurs when the thoracic and intrapulmonary volumes decrease and the intrapulmonary pressure increases. 116) \_\_\_\_
- 117) The amount of air that can be forcibly inhaled over the tidal volume is about 2100 to 3200 mL. 117) \_\_\_\_
- 118) The bronchioles are the smallest of the conducting passageways in the lungs. 118) \_\_\_\_
- 119) The nasal cavity is separated from the oral cavity by the nasal conchae. 119) \_\_\_\_
- 120) Wheezing is a whistling sound associated with diseased respiratory tissue, mucus, or pus. 120) \_\_\_\_
- 121) The C-shaped rings of cartilage that reinforce the trachea are made of elastic cartilage. 121) \_\_\_\_

**MATCHING. Choose the item in column 2 that best matches each item in column 1.**

*Match the following definitions with their associated respiratory volume or capacity:*

- |   |                          |                  |
|---|--------------------------|------------------|
| 122) Air that remains in the lungs even after the most strenuous expiration     | A) vital capacity        | 122) ____        |
|   | B) total lung capacity   |                  |
| 123) Amount of air that can be forcibly exhaled after a normal tidal expiration |                          | 123) ____        |
|   | C) dead space volume     |                  |
| 124) Sum total of tidal volume, inspiratory reserve volume, and expiratory      | r      serve volume<br>e | D)expira<br>tory |

reserve volume

- 124) \_\_\_\_\_  
E) residual volume

*Match the following mechanism with its associated nonrespiratory movement:*

- 125) Blast of upward rushing air that clears the lower respiratory passageways  
A) coughing 125) \_\_\_\_\_  
B) throat-clearing

*Match the following definitions with their associated respiratory volume or capacity:*

- 126) Air that enters the respiratory tract and remains within the conducting zone passageways  
A) residual volume 126) \_\_\_\_\_  
B) conducting zone volume  
127) Amount of air that can be inhaled forcibly over the tidal volume  
C) dead space volume 127) \_\_\_\_\_  
D) inspiratory reserve volume

*Match the following structure with its description:*

- 128) The trachea branches into these tubes  
A) main (primary) bronchi 128) \_\_\_\_\_  
129) Tube posterior to the trachea  
B) esophagus 129) \_\_\_\_\_

*Match the following definitions with their associated respiratory volume or capacity:*

- 130) Total amount of exchangeable air  
A) tidal volume 130) \_\_\_\_\_  
B) vital capacity

*Match the following structure with its description:*

- 131) Voice box  
A) larynx 131) \_\_\_\_\_

*Match the following mechanism with its associated nonrespiratory movement:*

- 132) Involves using the uvula to close the oral cavity off from the pharynx in order to clear the upper respiratory passages  
A) sneezing 132) \_\_\_\_\_  
B) coughing

*Match the following structure with its description:*

- 133) Windpipe  
A) trachea 133) \_\_\_\_\_

*Match the following definitions with their associated respiratory volume or capacity:*

- 134) Normal, quiet breathing which moves approximately 500 mL of air per breath  
A) vital capacity 134) \_\_\_\_\_  
B)

tidal volume

*Match the following mechanism with its associated nonrespiratory movement:*

- |  |               |            |
|--|---------------|------------|
| 135) Primarily an emotionally induced mechanism that involves release of air in a number of short breaths, similar to laughing | A) yawning    | 135) _____ |
|  | B) hiccupping |            |
| 136) A very deep inspiration formerly believed to be triggered by low oxygen   | C) crying     | 136) _____ |

*Match the following structure with its description:*

- |   |                |            |
|---|----------------|------------|
| 137) Opening to the larynx                        | A) pharynx     | 137) _____ |
| 138) Smallest conducting passageways in the lungs | B) glottis     | 138) _____ |
| 139) Air sacs within the lungs                    | C) alveoli     | 139) _____ |
| 140) Throat                                       | D) bronchioles | 140) _____ |

*Match the following mechanism with its associated nonrespiratory movement:*

- |  |               |            |
|--|---------------|------------|
| 141) Sudden inspirations resulting from spasms of the diaphragm                    | A) coughing   | 141) _____ |
| 142) An emotionally induced response that produces air movements similar to crying | B) yawning    | 142) _____ |
|  | C) hiccupping |            |
|  | D) laughing   |            |

**ESSAY. Write your answer in the space provided or on a separate sheet of paper.**

- 143) Describe some of the major and minor effects of smoking on the human body.
- 144) Explain the structure and function of the respiratory membrane.
- 145) Explain the roles of mucus and cilia in the respiratory system.
- 146) Identify and describe the four distinct events that are collectively called respiration.
- 147) List the three regions of the pharynx and identify their relative superior and inferior endpoints in the respiratory passageway.
- 148) Describe how oxygen and carbon dioxide are transported in the blood.



149) Explain the role of the epiglottis in the respiratory system.

150) Identify the two pleural membranes and describe them under normal and disease conditions.

- 1) C
- 2) D
- 3) E
- 4) E
- 5) A
- 6) D
- 7) D
- 8) D
- 9) A
- 10) D
- 11) D
- 12) B
- 13) D
- 14) E
- 15) B
- 16) A
- 17) C
- 18) C
- 19) E
- 20) C
- 21) B
- 22) B
- 23) B
- 24) C
- 25) D
- 26) B
- 27) C
- 28) D
- 29) B
- 30) A
- 31) B
- 32) A
- 33) B
- 34) E
- 35) D
- 36) C
- 37) B
- 38) B
- 39) C
- 40) E
- 41) A
- 42) C
- 43) A
- 44) E
- 45) B
- 46) C
- 47) E
- 48) A
- 49) C
- 50) C
- 51) Adam's apple

- 52) 500
- 53) dead space volume
- 54) bicarbonate ion
- 55) I
- 56) J
- 57) C
- 58) carbon dioxide
- 59) pneumothorax
- 60) emphysema
- 61) trachea
- 62) pulmonary ventilation
- 63) B
- 64) hard palate
- 65) sneeze
- 66) asthma
- 67) Heimlich maneuver
- 68) D
- 69) macrophages
- 70) G
- 71) H
- 72) carbon dioxide
- 73) eupnea
- 74) conchae
- 75) A
- 76) pharyngeal tonsils; adenoids
- 77) diaphragm; external intercostals
- 78) internal respiration
- 79) bronchioles
- 80) alveoli
- 81) crackle
- 82) sinusitis
- 83) oxyhemoglobin
- 84) spirometer
- 85) epiglottis
- 86) E
- 87) mediastinum
- 88) hyaline
- 89) pharynx
- 90) glottis
- 91) hypoxia
- 92) F
- 93) TRUE
- 94) TRUE
- 95) TRUE
- 96) TRUE
- 97) TRUE
- 98) TRUE
- 99) FALSE
- 100) FALSE
- 101) TRUE
- 102) TRUE
- 103) TRUE

- 104) FALSE
- 105) TRUE
- 106) FALSE
- 107) FALSE
- 108) TRUE
- 109) TRUE
- 110) FALSE
- 111) TRUE
- 112) TRUE
- 113) FALSE
- 114) TRUE
- 115) FALSE
- 116) TRUE
- 117) TRUE
- 118) TRUE
- 119) FALSE
- 120) TRUE
- 121) FALSE
- 122) E
- 123) D
- 124) A
- 125) A
- 126) C
- 127) D
- 128) A
- 129) B
- 130) B
- 131) A
- 132) A
- 133) A
- 134) B
- 135) C
- 136) A
- 137) B
- 138) D
- 139) C
- 140) A
- 141) C
- 142) D

- 143) Answers will vary depending on what effects were discussed in class, since smoking has numerous effects on the body. Respiratory effects include airway obstruction, dyspnea, coughing, frequent infections, breakdown of elastin in the connective tissue in the lungs, continual bronchial irritation and inflammation, hypoxia, respiratory acidosis, and respiratory failure. Other effects include clubbing of the fingers due to hypoxia, impotence, and impairment of the immune system.
- 144) The respiratory membrane, also known as the air–blood barrier, is comprised of the fused basement membranes of the alveolar and capillary walls. It has gas flowing past on one side and blood flowing past on the other. Gas exchanges occur by simple diffusion through the respiratory membrane. Oxygen passes from the alveolar air into the capillary blood and carbon dioxide leaves the blood to enter the gas–filled alveoli.
- 145) Respiratory mucosa lines the nasal cavity which produces sticky mucus. This mucus moistens the air and traps incoming bacteria and other foreign debris entering the nasal cavity. The ciliated cells of the nasal mucosa move this contaminated mucus posteriorly toward the pharynx where it can be swallowed. The trachea is also lined with ciliated mucosa. These cilia move contaminated mucus toward the throat where it either can be swallowed or spat

out.

- 146) Pulmonary ventilation is commonly called *breathing* and involves the movement of air into and out of the lungs. External respiration is the exchange of gases between the pulmonary blood and the alveoli. Respiratory gas transport is the transport of oxygen and carbon dioxide to and from the lungs and tissue cells of the body via the bloodstream. Internal respiration is the exchange of gases between the blood and tissue cells.
- 147) The three portions of the pharynx are the nasopharynx, the oropharynx, and the laryngopharynx. The nasopharynx is the superior portion that extends from the nasal cavity to the soft palate. The oropharynx is the central portion that lies between the soft palate and the upper epiglottis. The laryngopharynx is the most inferior portion and is the connecting point to the larynx below.
- 148) Oxygen is transported in two ways:
1. Most oxygen attaches to hemoglobin molecules on the RBCs to form oxyhemoglobin.
  2. A small amount of oxygen dissolves in the plasma for transport.
- Carbon dioxide is also transported in two ways:
1. Most carbon dioxide dissolves in the plasma as the bicarbonate ion.
  2. A small amount of carbon dioxide is carried inside the RBCs bound to hemoglobin (bound to a different site from oxygen).
- 149) The epiglottis is a part of the larynx. This structure is made of elastic cartilage. The epiglottis protects the superior opening (glottis) of the trachea. When we swallow foods or fluids, the larynx is pulled upward and the epiglottis tips to form a lid over the opening of the larynx. Food and fluids are then forced into the posterior tube called the esophagus.
- 150) The pleural membranes, the visceral pleura and the parietal pleura, produce a slippery serous secretion that allows the lungs to glide easily over the thorax wall during breathing. This serous fluid causes the two pleural layers to cling together. They can slide easily from side to side across one another, but they cannot easily be pulled apart. As surface tension of water holds them tightly to each other, the lungs are held tightly to the thorax wall. The pleural space is more of a potential space than an actual space, and it is only during illness or injury that this space becomes apparent, such as with a pneumothorax that can lead to atelectasis.

Exam

Name \_\_\_\_\_

**MULTIPLE CHOICE. Choose the one alternative that best completes the statement or answers the question.**

- 1) Adenosine triphosphate (ATP) is produced in greatest quantity during: 1) \_\_\_\_\_
  - A) fat metabolism
  - B) glycolysis
  - C) protein metabolism
  - D) the Krebs cycle
  - E) the electron transport chain
  
- 2) Which of the following influence the release of pancreatic juice and bile: 2) \_\_\_\_\_
  - A) cholecystokinin and secretin
  - B) secretin and gastrin
  - C) cholecystokinin and gastrin
  - D) rennin and cholecystokinin
  - E) gastrin and rennin
  
- 3) The process by which larger molecules or structures are built up from smaller ones is called: 3) \_\_\_\_\_
  - A) carbolysis
  - B) catabolism
  - C) metabolism
  - D) anabolism
  - E) glycolysis
  
- 4) Which one of the following alimentary segments has no digestive function: 4) \_\_\_\_\_
  - A) ascending colon
  - B) stomach
  - C) esophagus
  - D) duodenum
  - E) ileum
  
- 5) The release of food from the stomach into the small intestine is regulated by the: 5) \_\_\_\_\_
  - A) cardioesophageal sphincter
  - B) hepatopancreatic ampulla
  - C) ileocecal valve
  - D) pyloric sphincter (valve)
  - E) internal anal sphincter
  
- 6) Which one of the following is NOT absorbed by the human large intestine: 6) \_\_\_\_\_
  - A) vitamin K
  - B) water
  - C) ions
  - D) some of the B vitamins
  - E) protein
  
- 7) Which one of the following is NOT true of cholesterol: 7) \_\_\_\_\_
  - A) only about 15 percent comes from the diet
  - B) it provides energy fuel for muscle contraction
  - C) it serves as the structural basis of vitamin D
  - D) it is a major building block of plasma membranes
  - E) it serves as the structural basis of steroid hormones

- 8) The journey of chyme through the small intestine takes: 8) \_\_\_\_\_
- A) 10-12 hours
  - B) 8-10 hours
  - C) 6-8 hours
  - D) 2-4 hours
  - E) 3-6 hours
- 9) Transport of digested end products from the lumen GI tract into the bloodstream or lymphatic fluid is called: 9) \_\_\_\_\_
- A) ingestion
  - B) defecation
  - C) propulsion
  - D) digestion
  - E) absorption
- 10) The primary function of the small intestine is: 10) \_\_\_\_\_
- A) absorption of nutrients
  - B) mineral secretion
  - C) vitamin conversion
  - D) waste secretion
  - E) absorption of water
- 11) The submucosal and myenteric nerve plexuses that help regulate the mobility and secretory activity of the GI tract organs are both part of the: 11) \_\_\_\_\_
- A) fight-or-flight mechanism
  - B) somatic nervous system
  - C) central nervous system
  - D) autonomic nervous system
  - E) sympathetic nervous system
- 12) Which one of the following is NOT true of the sensors involved in digestive reflexes: 12) \_\_\_\_\_
- A) they respond to stretch of the organ by the volume of food within its lumen
  - B) they respond to the relative pH content within that particular digestive organ
  - C) they start reflexes that either activate or inhibit digestive glands
  - D) they activate or inhibit lacteal absorption
  - E) they respond to the presence of breakdown products of digestion
- 13) The energy value of foods commonly counted by dieters is measured in units called: 13) \_\_\_\_\_
- A) ATP
  - B) kilocalories
  - C) coenzymes
  - D) calories
  - E) carb units
- 14) Buildup of bile within the liver leading to bile pigments circulating through the body could cause tissues to turn yellow and a condition called: 14) \_\_\_\_\_
- A) hepatitis
  - B) jaundice
  - C) cyanosis
  - D) cirrhosis
  - E) erythematosis

- 15) Digestion is primarily controlled by the: 15) \_\_\_\_\_  
A) parasympathetic division of the autonomic nervous system  
B) enterogastric reflex  
C) sympathetic division of the autonomic nervous system  
D) somatic nervous system  
E) medulla oblongata
- 16) The process of swallowing is also known as: 16) \_\_\_\_\_  
A) mastication  
B) defecation  
C) absorption  
D) segmentation  
E) deglutition
- 17) The opening of the large intestine is called the: 17) \_\_\_\_\_  
A) cecum  
B) sigmoid colon  
C) anus  
D) ileum  
E) rectum
- 18) The hereditary inability of tissue cells to metabolize the amino acid phenylalanine, which can result in brain damage and retardation unless a special diet low in phenylalanine is followed, is called: 18) \_\_\_\_\_  
A) tracheoesophageal fistula  
B) cystic fibrosis  
C) cleft lip  
D) phenylketonuria  
E) cleft palate
- 19) Enzyme-rich pancreatic juice contains all the following EXCEPT: 19) \_\_\_\_\_  
A) lipase  
B) nuclease  
C) amylase  
D) pancreatase  
E) trypsin
- 20) Which one of the following is the middle section of the small intestine: 20) \_\_\_\_\_  
A) ileum  
B) descending colon  
C) duodenum  
D) ascending colon  
E) jejunum
- 21) Nutrients detour through the liver via the: 21) \_\_\_\_\_  
A) electron transport chain  
B) hepatic portal circulation  
C) Bowman's capsule  
D) circle of Willis  
E) glycogenesis



- 22) The anterior chisel-shaped teeth that are adapted for cutting are called: 22) \_\_\_\_\_
- A) canines
  - B) incisors
  - C) premolars
  - D) wisdom teeth
  - E) molars
- 23) The process by which food within the small intestine is mixed with digestive juices by backward and forward movement across the internal wall of the organ is called: 23) \_\_\_\_\_
- A) chemical digestion
  - B) segmentation
  - C) absorption
  - D) defecation
  - E) peristalsis
- 24) Which one of the following represents the correct order through which food passes in the alimentary canal: 24) \_\_\_\_\_
- A) mouth, pharynx, esophagus, stomach, large intestine, small intestine
  - B) pharynx, mouth, esophagus, stomach, large intestine, small intestine
  - C) mouth, pharynx, esophagus, small intestine, stomach, large intestine
  - D) mouth, esophagus, pharynx, stomach, small intestine, large intestine
  - E) mouth, pharynx, esophagus, stomach, small intestine, large intestine
- 25) Which one of the following is NOT a subdivision of the large intestine: 25) \_\_\_\_\_
- A) appendix
  - B) colon
  - C) cecum
  - D) duodenum
  - E) rectum
- 26) The enzyme responsible for converting milk protein in the stomach to a substance that looks like sour milk in infants is: 26) \_\_\_\_\_
- A) salivary amylase
  - B) rennin
  - C) bile
  - D) pancreatic amylase
  - E) pepsin
- 27) Which one of the following is NOT involved in the swallowing reflex: 27) \_\_\_\_\_
- A) pharynx
  - B) tongue
  - C) soft palate
  - D) larynx
  - E) esophagus
- 28) The accessory digestive organ that produces enzymes that break down all food groups is the: 28) \_\_\_\_\_
- A) gallbladder
  - B) liver and gallbladder
  - C) pancreas
  - D) liver
  - E) salivary glands

- 29) Which one of the following is NOT one of the carbohydrates that the human digestive system is able to break down to simple sugars: 29) \_\_\_\_\_  
A) maltose      B) cellulose      C) lactose      D) sucrose      E) starch
- 30) The organ responsible for drying out indigestible food residue through water absorption and the elimination of feces is the: 30) \_\_\_\_\_  
A) small intestine  
B) large intestine  
C) stomach  
D) liver  
E) pancreas
- 31) The number of permanent teeth within a full set of adult teeth is: 31) \_\_\_\_\_  
A) 36      B) 20      C) 28      D) 32      E) 24
- 32) Enzymes and bile are carried by the pancreatic duct and bile duct into the: 32) \_\_\_\_\_  
A) ileum  
B) ileocecal valve  
C) large intestine  
D) duodenum  
E) jejunum
- 33) Which one of the following is NOT a main role of the liver: 33) \_\_\_\_\_  
A) to add ammonia to the blood  
B) to process nutrients during digestion  
C) to detoxify drugs and alcohol  
D) to make cholesterol  
E) to degrade hormones
- 34) The amount of gastric juice produced every day by an average-sized adult is: 34) \_\_\_\_\_  
A) 1-2 liters  
B) 2-3 liters  
C) 3-4 liters  
D) 2-3 gallons  
E) 1-2 gallons
- 35) The small intestine extends from the: 35) \_\_\_\_\_  
A) pyloric sphincter to the ileocecal valve  
B) ileocecal valve to the appendix  
C) cardioesophageal sphincter to ileocecal valve  
D) appendix to the sigmoid colon  
E) cardioesophageal sphincter to the pyloric sphincter
- 36) Proteins are digested to their building blocks which are called: 36) \_\_\_\_\_  
A) polypeptides  
B) fatty acids  
C) peptides  
D) amino acids  
E) glycerol
- 37) The structure that forms the anterior roof of the mouth is the: 37) \_\_\_\_\_  
A) teeth

- B) uvula
- C) hard palate
- D) cheek
- E) soft palate

- 38) Which one of the following is NOT a layer of the alimentary canal: 38) \_\_\_\_\_
- A) mucosa
  - B) muscularis interna
  - C) submucosa
  - D) serosa
  - E) muscularis externa
- 39) When full, the average adult stomach can hold approximately: 39) \_\_\_\_\_
- A) 2 gallons of food
  - B) 2 liters of food
  - C) 4 liters of food
  - D) 3 liters of food
  - E) 1 liter of food
- 40) Which one of the following is NOT a modification (which is designed to increase surface area for absorption) within the small intestine: 40) \_\_\_\_\_
- A) circular folds
  - B) plicae circulares
  - C) microvilli
  - D) villi
  - E) Peyer's patches
- 41) The fold of mucous membrane that secures the tongue to the floor of the mouth and limits its posterior movements is called the: 41) \_\_\_\_\_
- A) mandibular frenulum
  - B) lingual frenulum
  - C) styloid bone
  - D) palatal frenulum
  - E) hyoid bone
- 42) Bile is produced by the \_\_\_\_\_ but stored in the \_\_\_\_\_. 42) \_\_\_\_\_
- A) gallbladder; pancreas
  - B) small intestine; pancreas
  - C) liver; pancreas
  - D) gallbladder; liver
  - E) liver; gallbladder
- 43) Which one of the following is NOT an organ of the alimentary canal: 43) \_\_\_\_\_
- A) pharynx
  - B) teeth
  - C) mouth
  - D) esophagus
  - E) stomach
- 44) Inorganic substances necessary to body functioning that must be ingested through the diet are: 44) \_\_\_\_\_
- A) carbon
  - B) vitamins

- C) complete proteins
- D) coenzymes
- E) minerals

- 45) Intrinsic factor in digestion is a stomach secretion needed for absorption of \_\_\_\_\_ from the small intestine. 45) \_\_\_\_\_
- A) vitamin K
  - B) vitamin B12
  - C) vitamin C
  - D) vitamin A
  - E) vitamin D
- 46) The reflex that helps an infant hold on to the nipple and swallow is called the: 46) \_\_\_\_\_
- A) sucking reflex
  - B) fetal reflex
  - C) peristaltic reflex
  - D) rooting reflex
  - E) nursing reflex
- 47) Amylase is an enzyme that is only able to digest: 47) \_\_\_\_\_
- A) starch
  - B) minerals
  - C) vitamins
  - D) fat
  - E) protein
- 48) The hormone responsible for causing the stomach to release pepsinogens, mucus, and hydrochloric acid is: 48) \_\_\_\_\_
- A) bile
  - B) amylase
  - C) rennin
  - D) gastrin
  - E) pepsin
- 49) The liver metabolizes fats for all of the following reasons EXCEPT: 49) \_\_\_\_\_
- A) synthesis of lipoproteins
  - B) synthesis of vitamin K
  - C) ATP production
  - D) synthesis of thromboplastin
  - E) synthesis of cholesterol
- 50) Acidosis (ketoacidosis) occurs when \_\_\_\_\_ is digested. 50) \_\_\_\_\_
- A) glycogen
  - B) glycogen or glucose
  - C) protein
  - D) fat
  - E) glucose
- 51) Which one of the following is continuous with the esophagus: 51) \_\_\_\_\_
- A) linguopharynx
  - B) nasopharynx
  - C) oropharynx
  - D) laryngopharynx
  - E) esophagopharynx
- 52) Protein digestion begins in the: 52) \_\_\_\_\_
- A) small intestine
  - B) large intestine
  - C) stomach
  - D) mouth

E) esophagus

53) The propulsive process that moves food from one organ to the next is called: 53) \_\_\_\_\_  
A) mastication  
B) chemical digestion  
C) ingestion  
D) absorption  
E) peristalsis

54) The first nutrient to be chemically digested is: 54) \_\_\_\_\_  
A) vitamins      B) fat      C) starch      D) protein      E) minerals

55) The sequence of steps by which large food molecules are broken down into their respective building blocks by catalytic enzymes within hydrolysis reactions is called: 55) \_\_\_\_\_  
A) mechanical digestion  
B) propulsion  
C) ingestion  
D) absorption  
E) chemical digestion

**SHORT ANSWER. Write the word or phrase that best completes each statement or answers the question.**

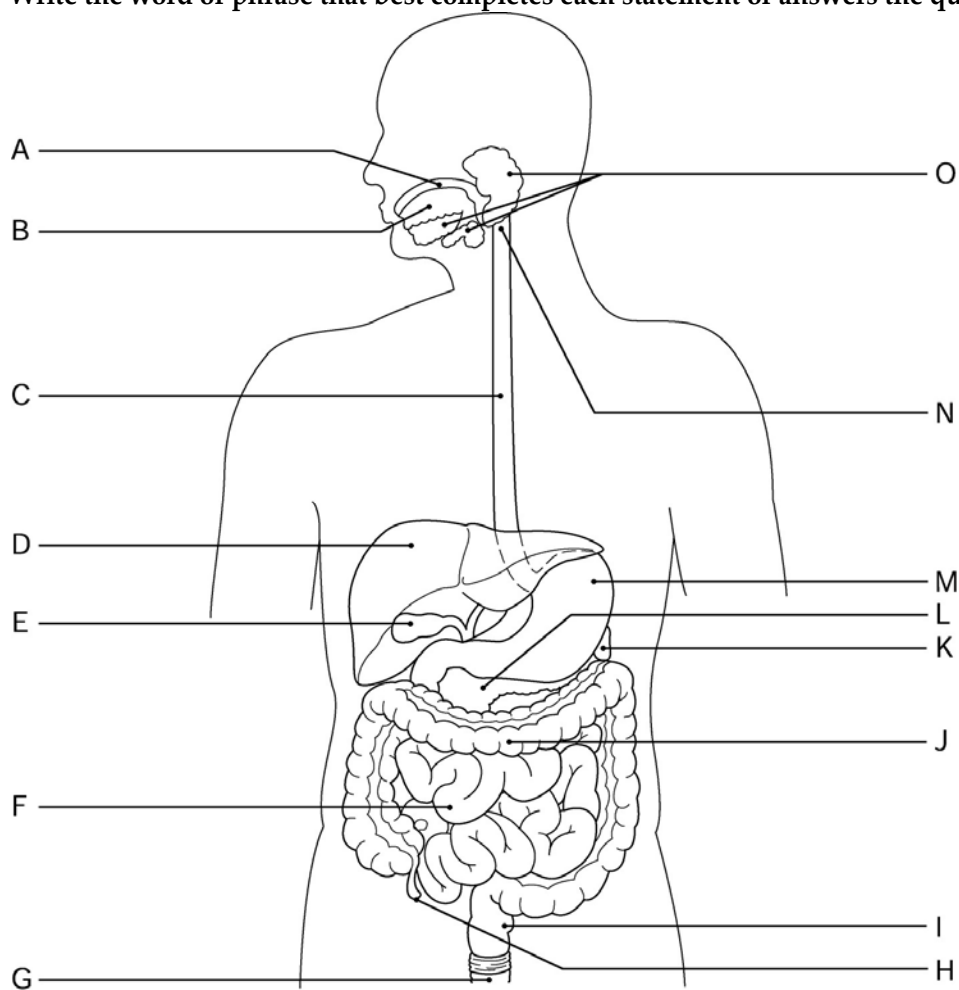

Figure 14.1

Using Figure 14.1, identify the following:

56) The esophagus is indicated by letter \_\_\_\_\_.

56) \_\_\_\_\_

*Fill in the blank or provide a short answer:*

57) The enamel-covered crown of the tooth is exposed just above the \_\_\_\_\_.

57) \_\_\_\_\_

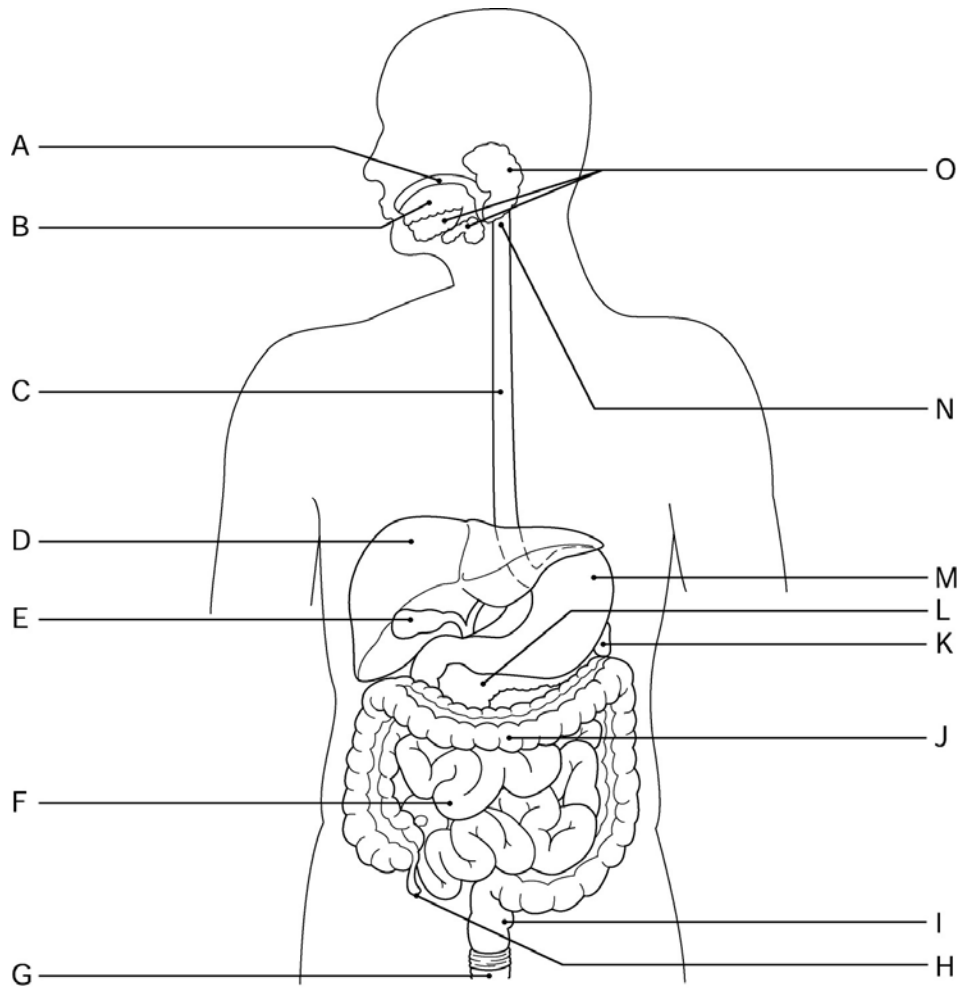

Figure 14.1

*Using Figure 14.1, identify the following:*

58) The pancreas is indicated by letter \_\_\_\_\_.

58) \_\_\_\_\_

*Fill in the blank or provide a short answer:*

59) The polysaccharide, glycogen, is formed from the combination of thousands of glucose molecules during a process called \_\_\_\_\_.

59) \_\_\_\_\_

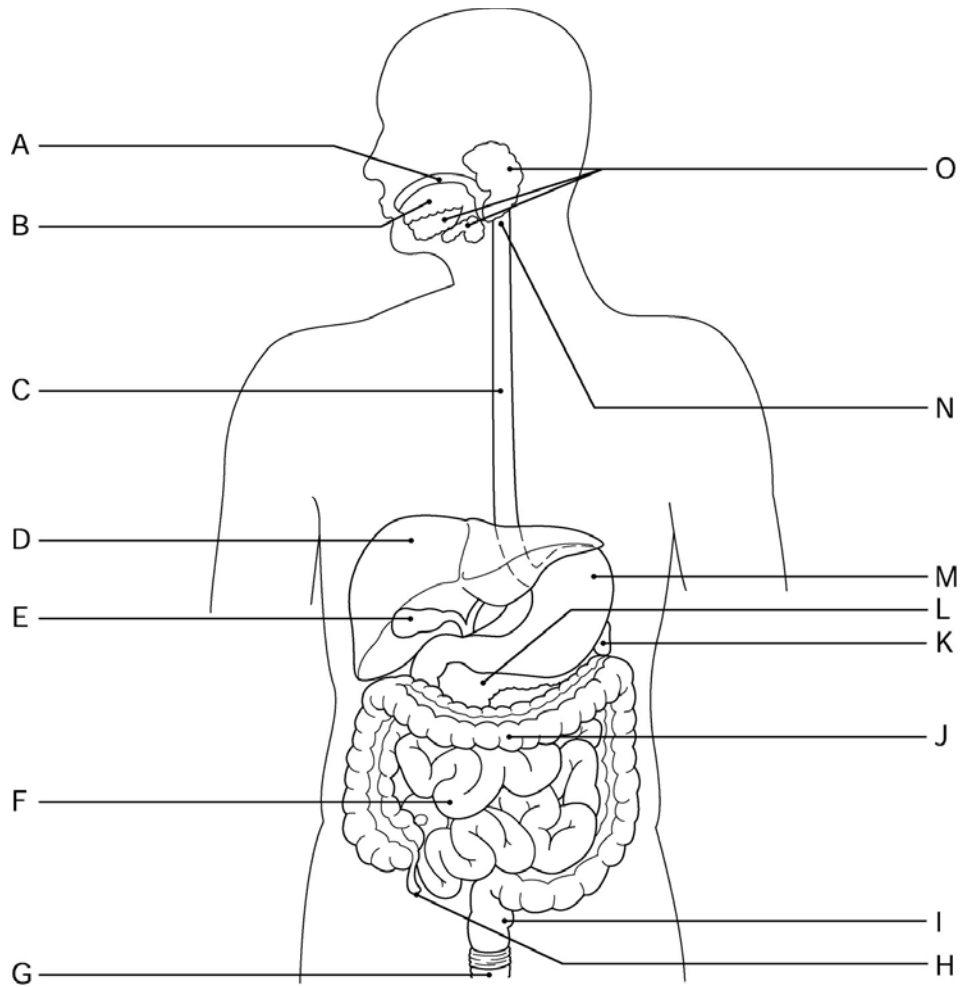

Figure 14.1

Using Figure 14.1, identify the following:

60) The salivary glands are indicated by letter \_\_\_\_\_.

60) \_\_\_\_\_

Fill in the blank or provide a short answer:

61) The chemical responsible for about half of protein digestion and all of fat digestion is \_\_\_\_\_.

61) \_\_\_\_\_

62) The emetic (vomiting) center in the brain is called the \_\_\_\_\_.

62) \_\_\_\_\_

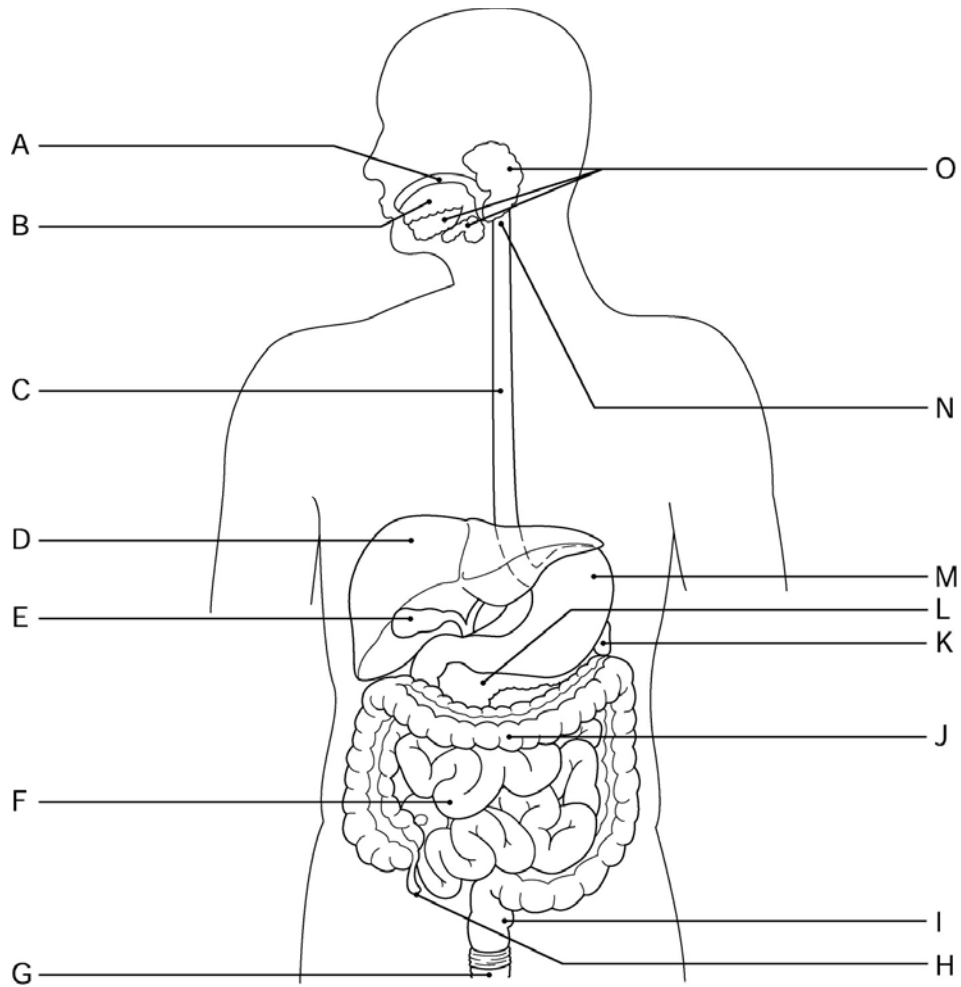

Figure 14.1

Using Figure 14.1, identify the following:

63) The small intestine is indicated by letter \_\_\_\_\_. 63) \_\_\_\_\_

Fill in the blank or provide a short answer:

64) The voluntary process of placing food into the mouth is referred to as \_\_\_\_\_. 64) \_\_\_\_\_

65) The sphincter that prevents food from leaving the stomach is the \_\_\_\_\_ sphincter. 65) \_\_\_\_\_



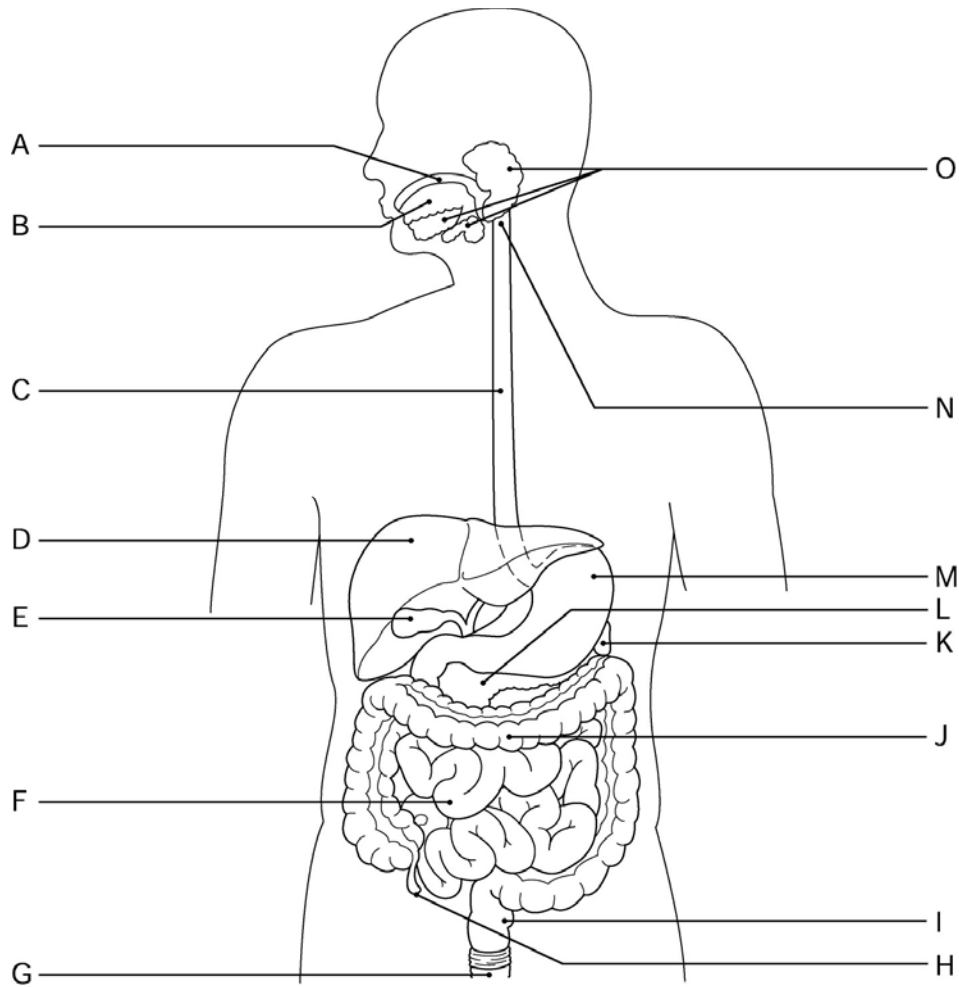

Figure 14.1

Using Figure 14.1, identify the following:

66) The stomach is indicated by letter \_\_\_\_\_. 66) \_\_\_\_\_

Fill in the blank or provide a short answer:

67) The sphincter found at the distal end of the esophagus is the \_\_\_\_\_ sphincter. 67) \_\_\_\_\_

68) The lipoprotein that transports cholesterol and other lipids to body cells is called \_\_\_\_\_. 68) \_\_\_\_\_

69) Large wrinklelike folds in the stomach lining, present when the stomach is empty, that allow for expansion when the stomach is filling are called \_\_\_\_\_. 69) \_\_\_\_\_

70) A chemical reaction in which substances are broken down into simpler substances is referred to as \_\_\_\_\_. 70) \_\_\_\_\_

71) Bile is formed by the \_\_\_\_\_. 71) \_\_\_\_\_

72) Two items absorbed through the stomach walls are \_\_\_\_\_ and \_\_\_\_\_. 72) \_\_\_\_\_

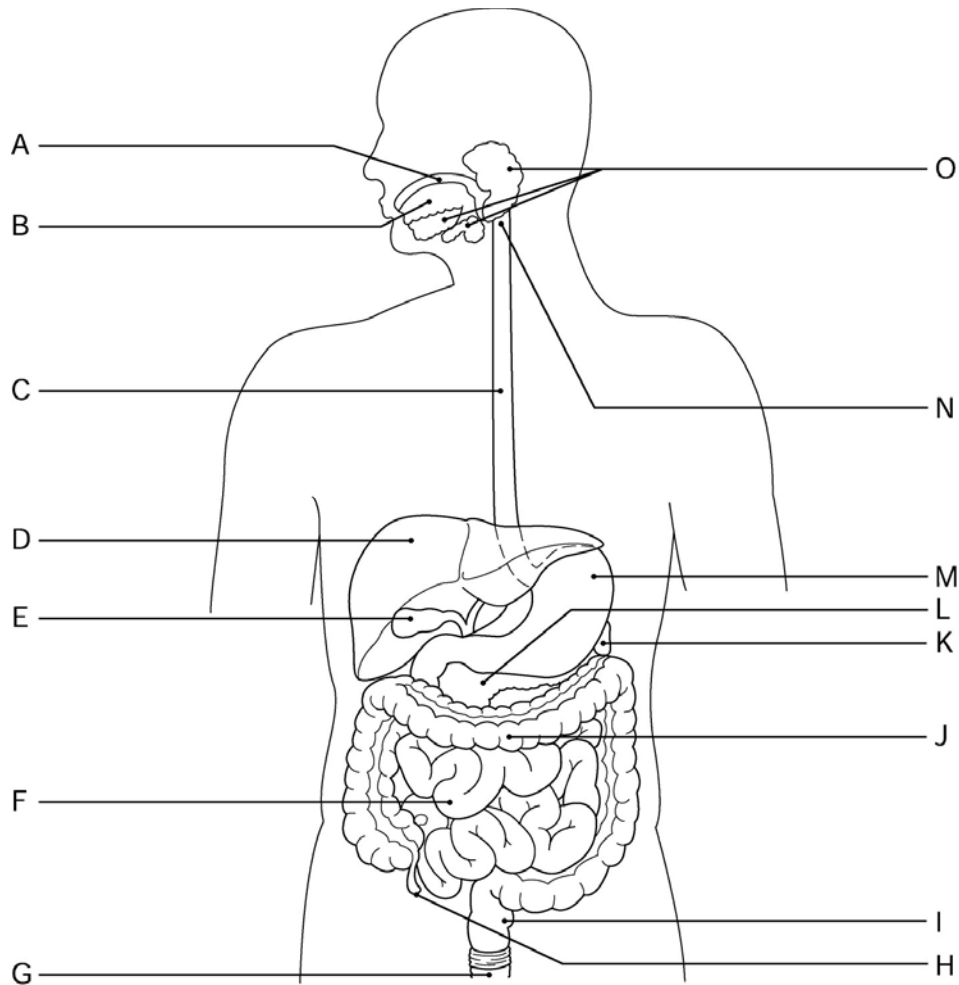

Figure 14.1

Using Figure 14.1, identify the following:

- 73) The pharynx is indicated by letter \_\_\_\_\_.
- 74) The mouth (oral cavity) is indicated by letter \_\_\_\_\_.

Fill in the blank or provide a short answer:

- 75) The hormone responsible for promoting the release of pepsinogens, mucus, and hydrochloric acid in the stomach is called \_\_\_\_\_.
- 76) Segmentation is a type of mechanical digestion that occurs only in the \_\_\_\_\_.
- 77) The energy value of foods is measured in units called \_\_\_\_\_.
- 78) The rich capillary bed and modified lymphatic capillary found within each villus is called a \_\_\_\_\_.

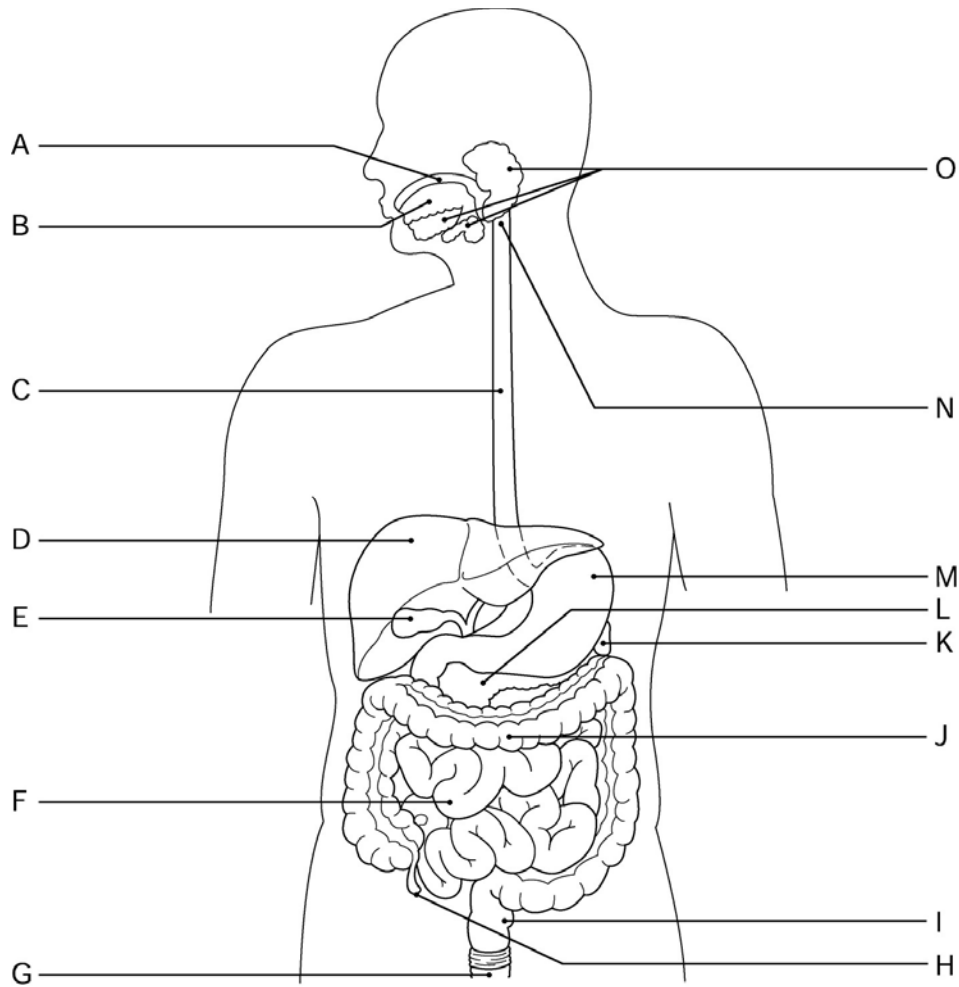

Figure 14.1

Using Figure 14.1, identify the following:

79) The tongue is indicated by letter \_\_\_\_\_.

79) \_\_\_\_\_

80) The liver is indicated by letter \_\_\_\_\_.

80) \_\_\_\_\_

81) The spleen is indicated by letter \_\_\_\_\_.

81) \_\_\_\_\_

Fill in the blank or provide a short answer:

82) When feces are forced into the rectum by mass movements and the wall of the rectum becomes stretched, the \_\_\_\_\_ is initiated.

82) \_\_\_\_\_

83) Amino acids that cannot be made by human body cells and therefore must be ingested in the diet are said to be \_\_\_\_\_.

83) \_\_\_\_\_

84) The process of eliminating indigestible residues from the GI tract is called \_\_\_\_\_.

84) \_\_\_\_\_

85) The material on the outermost surface of the root that attaches a tooth to the periodontal membrane (ligament) is called \_\_\_\_\_.

85) \_\_\_\_\_

86) Bile breaks large fat globules into smaller ones to provide more surface area for fat-digesting enzymes to operate in a process known as \_\_\_\_\_.

86) \_\_\_\_\_

- 87) The organ that connects the pharynx to the stomach is the \_\_\_\_\_.
- 88) In order for fats to be used for ATP synthesis, they must be broken down to form \_\_\_\_\_.
- 89) The specific metabolic pathway of cellular respiration in which virtually all carbon dioxide is made is the \_\_\_\_\_.
- 90) The upper, expanded part of the stomach lateral to the cardiac region is called the \_\_\_\_\_.

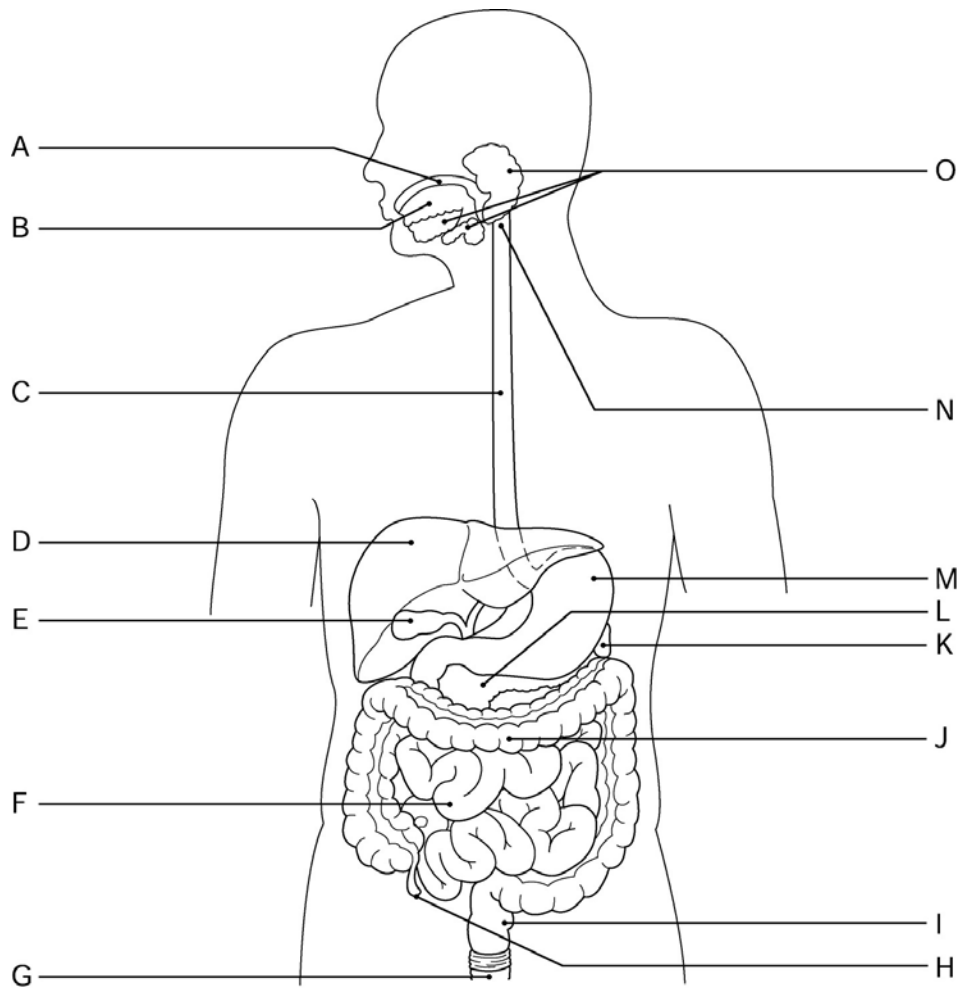

Figure 14.1

Using Figure 14.1, identify the following:

- 91) The appendix is indicated by letter \_\_\_\_\_.

Fill in the blank or provide a short answer:

- 92) The serosal membrane lining the abdominopelvic cavity by way of the mesentery is called the \_\_\_\_\_.

- 93) Food that resembles heavy cream after being processed in the stomach is called \_\_\_\_\_.

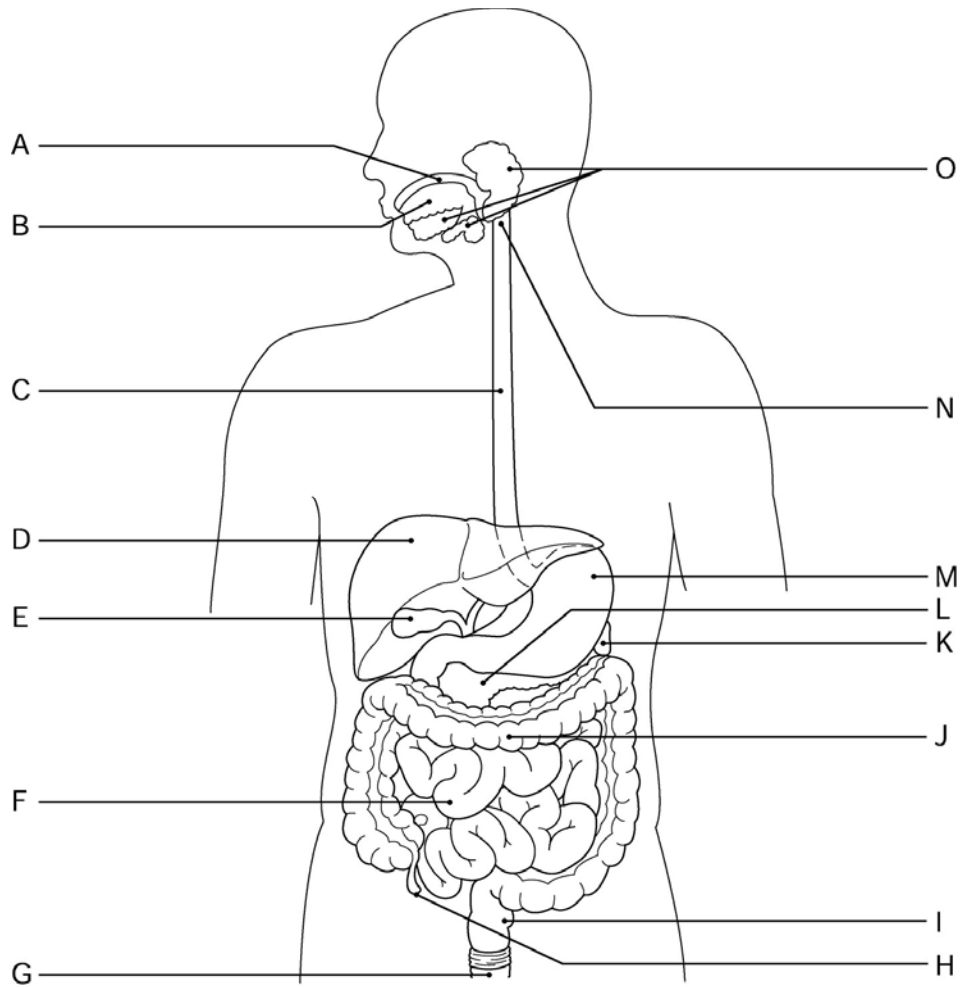

Figure 14.1

Using Figure 14.1, identify the following:

94) The gallbladder is indicated by letter \_\_\_\_\_.

94) \_\_\_\_\_

Fill in the blank or provide a short answer:

95) The total amount of kilocalories the body must consume to fuel all ongoing activities, which increases dramatically during physical exertion, is called the \_\_\_\_\_.

95) \_\_\_\_\_

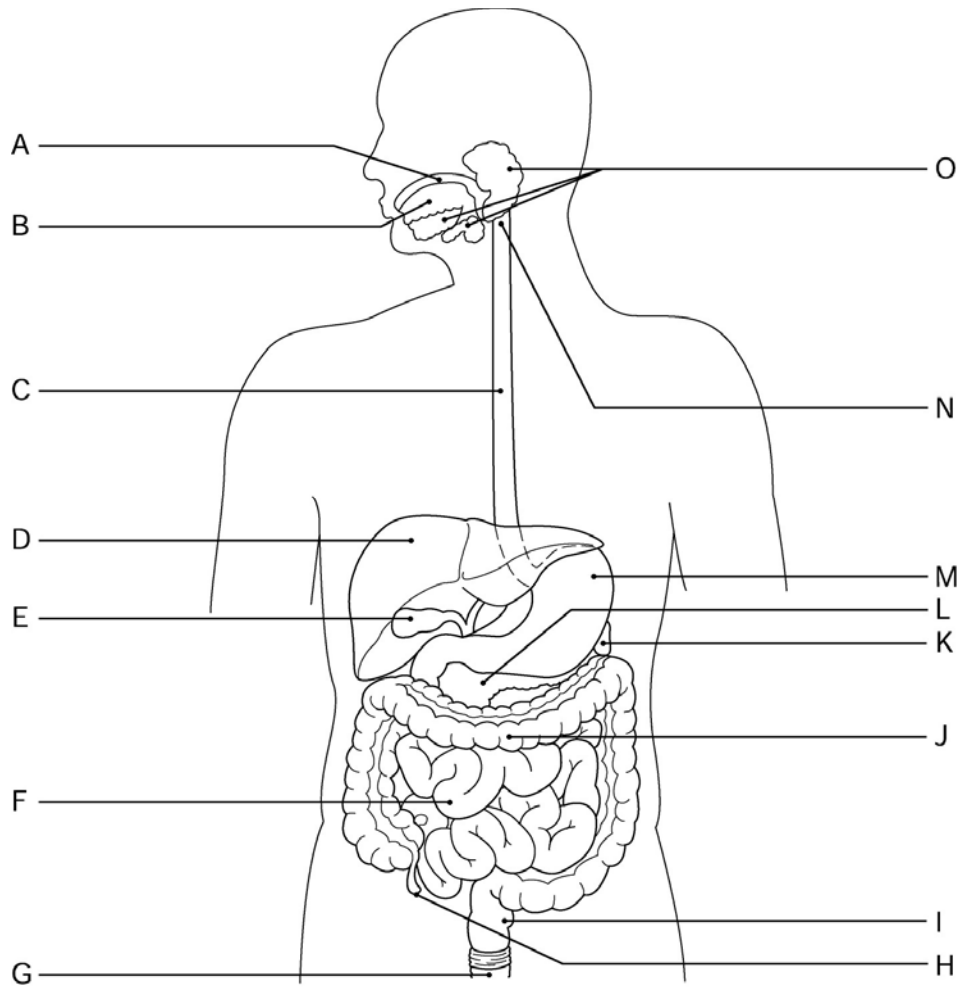

Figure 14.1

Using Figure 14.1, identify the following:

96) The rectum is indicated by letter \_\_\_\_\_.

96) \_\_\_\_\_

Fill in the blank or provide a short answer:

97) The opening on the terminal end of the large intestine is called the \_\_\_\_\_.

97) \_\_\_\_\_

98) Milk teeth that begin to erupt at around six months are also called the \_\_\_\_\_.

98) \_\_\_\_\_

99) Chemical substances released by macrophages and white blood cells that cause an upward resetting of the body's thermostat are called \_\_\_\_\_.

99) \_\_\_\_\_

100) The major fuel for making ATP in most cells of the body is a type of carbohydrate known as \_\_\_\_\_.

100) \_\_\_\_\_

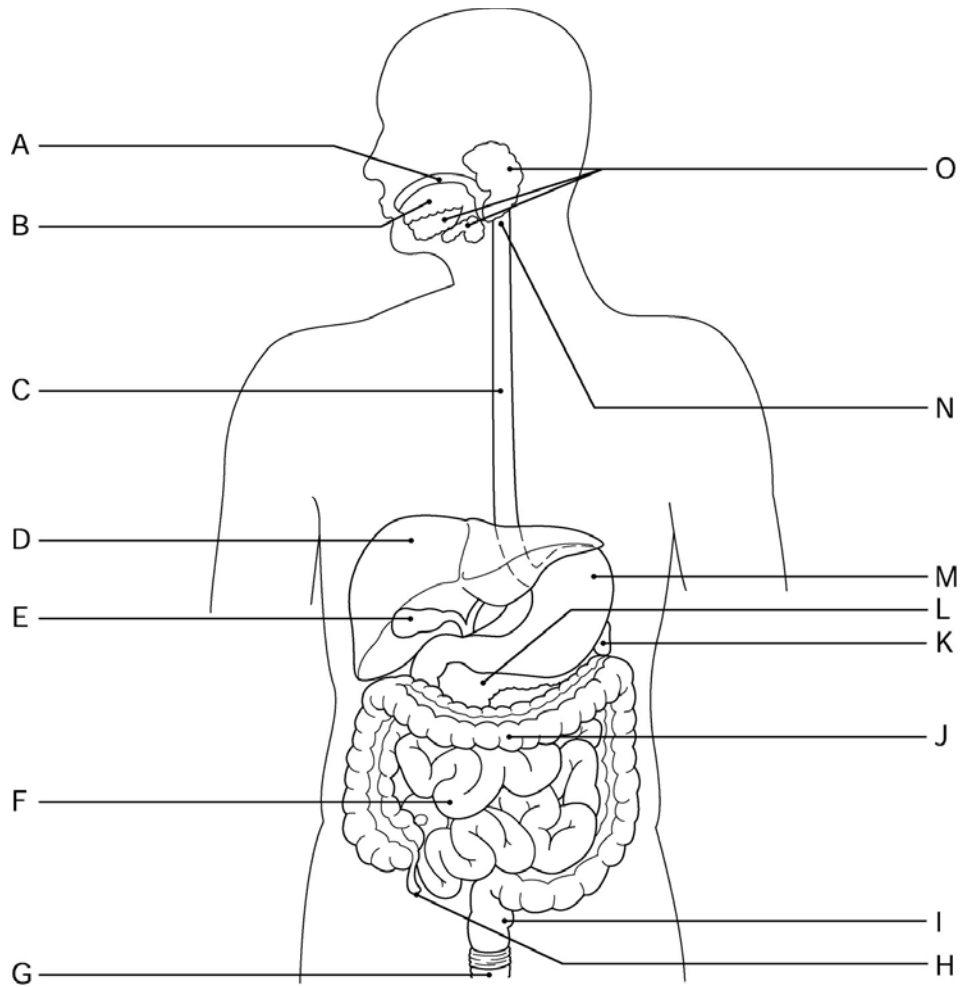

Figure 14.1

Using Figure 14.1, identify the following:

101) The large intestine is indicated by letter \_\_\_\_\_. 101) \_\_\_\_\_

Fill in the blank or provide a short answer:

102) Cells abundant within the large intestine that produce large amounts of lubricating mucus to aid in the passage of feces to the end of the digestive tract are called \_\_\_\_\_. 102) \_\_\_\_\_

103) The last subdivision of the small intestine is called the \_\_\_\_\_. 103) \_\_\_\_\_

104) The innermost layer of the alimentary canal is referred to as the \_\_\_\_\_. 104) \_\_\_\_\_

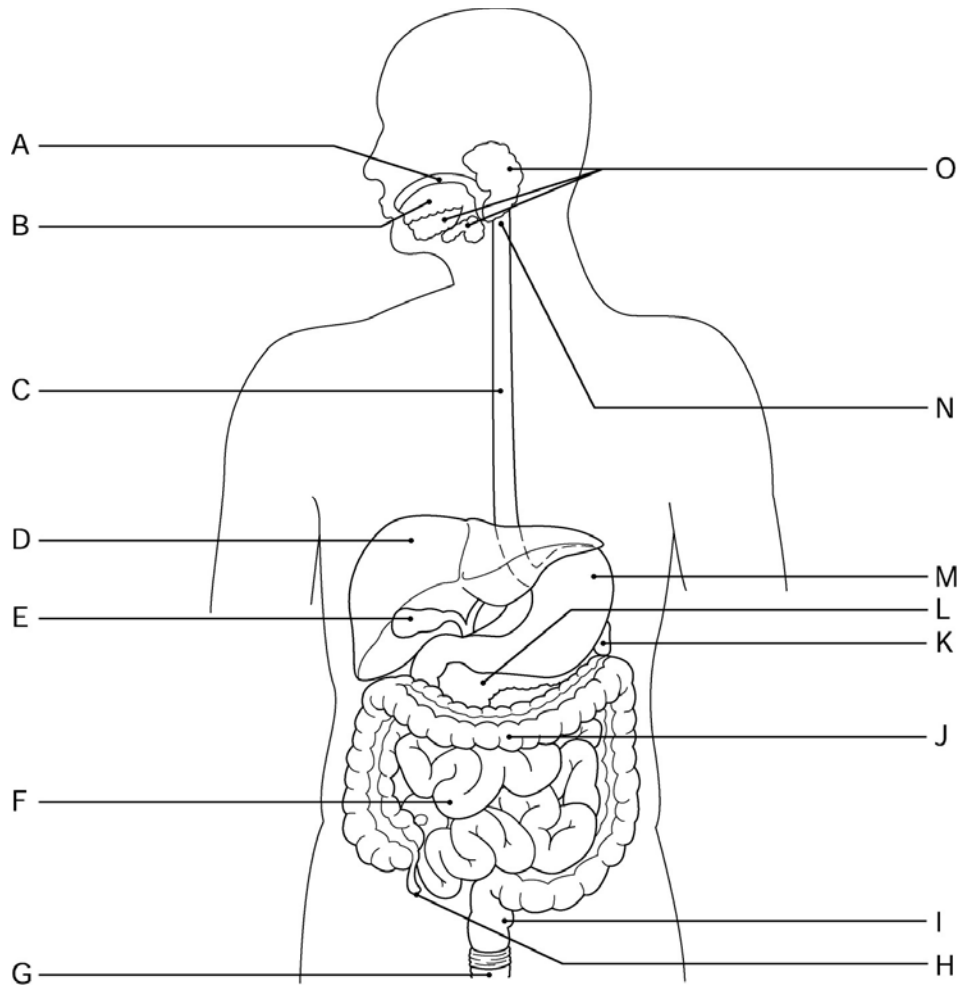

Figure 14.1

Using Figure 14.1, identify the following:

105) The anus is indicated by letter \_\_\_\_\_.

105) \_\_\_\_\_

**TRUE/FALSE. Write 'T' if the statement is true and 'F' if the statement is false.**

106) The ascending colon is found on the left side of the abdominal cavity.

106) \_\_\_\_\_

107) Bile enters the duodenum of the small intestine through the pancreatic duct.

107) \_\_\_\_\_

108) The chief cells produce hydrochloric acid, which activates stomach enzymes.

108) \_\_\_\_\_

109) Watery stools that result when food residue is rushed through the large intestine before sufficient water has been reabsorbed, causing dehydration and electrolyte imbalance, is called constipation.

109) \_\_\_\_\_

110) The innermost layer of the serosa is called the parietal peritoneum.

110) \_\_\_\_\_

111) Optimal health of tissues is achieved when HDL and LDL are present in equal amounts within the bloodstream.

111) \_\_\_\_\_

112) The lacy apron of the peritoneum that covers the abdominal organs is called the lesser omentum.

112) \_\_\_\_\_

113) The body's thermostat, which constantly regulates body temperature, is located within the

hypothala



- 114) Another name for the alimentary canal is the gastrointestinal (GI) tract. 114) \_\_\_\_\_
- 115) Secretin and cholecystikin influence the release of both pancreatic juice and bile. 115) \_\_\_\_\_
- 116) Fat metabolism can result in acidosis (ketoacidosis). 116) \_\_\_\_\_
- 117) Mass movements are slow-moving contractile waves that move over large areas of the colon three or four times each day. 117) \_\_\_\_\_
- 118) Food within the lumen of the alimentary canal is considered to be outside the body. 118) \_\_\_\_\_
- 119) The enamel found on teeth is heavily mineralized with calcium salts and comprises the hardest substance within the entire body. 119) \_\_\_\_\_
- 120) The process of mastication is simply known as chewing. 120) \_\_\_\_\_
- 121) Bile is produced by the liver but stored in the gallbladder. 121) \_\_\_\_\_
- 122) Anabolism is the process in which larger molecules are built from smaller ones. 122) \_\_\_\_\_
- 123) Diverticulosis occurs when mucosa become inflamed and protrude through the wall of the small intestine. 123) \_\_\_\_\_
- 124) Sugars and starches are classified as lipids. 124) \_\_\_\_\_
- 125) Villi are projections of the mucosa of the stomach. 125) \_\_\_\_\_
- 126) The involuntary phase of swallowing is called the buccal phase. 126) \_\_\_\_\_
- 127) Pancreatic enzymes are released into the stomach to break down all categories of digestible foods. 127) \_\_\_\_\_
- 128) The segment of the colon to which the appendix is attached is the cecum. 128) \_\_\_\_\_
- 129) Small pocketlike sacs within the large intestine that most often are partially contracted are called haustra. 129) \_\_\_\_\_
- 130) The small intestine runs from the pyloric sphincter to the ileocecal valve. 130) \_\_\_\_\_
- 131) The bicuspid are also called wisdom teeth. 131) \_\_\_\_\_
- 132) Absence of either bile or pancreatic juice indicates that no fat digestion or absorption is occurring. This can lead to blood-clotting problems because the liver needs vitamin K to make prothrombin. 132) \_\_\_\_\_
- 133) The rhythmic, wavelike propelling mechanism of the alimentary canal is called peristalsis. 133) \_\_\_\_\_
- 134) Fats are absorbed by active transport in the small intestine. 134) \_\_\_\_\_

135) The first portion of the small intestine is the jejunum. 135) \_\_\_\_\_

136) Enzymes of the microvilli are called brush border enzymes. 136) \_\_\_\_\_

137) The anal canal has a voluntary sphincter formed by smooth muscle only. 137) \_\_\_\_\_

**MATCHING. Choose the item in column 2 that best matches each item in column 1.**

*Identify the digestive organ that is primarily associated with the following digestive function:*

138) Site where pancreatic enzymes and bile enter the alimentary canal A) ileum 138) \_\_\_\_\_

B) duodenum

*Match the following terms or phrases with the appropriate nutrient:*

139) Glucose and glycogen A) carbohydrates 139) \_\_\_\_\_

*Identify the digestive organ that is primarily associated with the following digestive function:*

140) Tube through which food is propelled but no digestion takes place A) anus 140) \_\_\_\_\_

B) esophagus

141) Site of initiation of the defecation reflex 141) \_\_\_\_\_

C) small intestine

D) rectum

*Match the following nutrients with their associated digestive enzymes:*

142) Proteins A) hydrochloric acid 142) \_\_\_\_\_

B) pepsinogens

*Match the following terms or phrases with the appropriate nutrient:*

143) Amino acids A) proteins 143) \_\_\_\_\_

*Match the following nutrients with their associated digestive enzymes:*

144) Nucleic acids A) nuclease 144) \_\_\_\_\_

B) lipase

*Identify the digestive organ that is primarily associated with the following digestive function:*

145) Site where the beginning of protein digestion occurs A) small intestine 145) \_\_\_\_\_

B) stomach

*Match the following terms or phrases with the appropriate nutrient:*

146) Coenzymes A) vitamins 146) \_\_\_\_\_

*Identify the digestive organ that is primarily associated with the following digestive function:*

147) Site of vitamin K synthesis by bacteria A) mouth

147) \_\_\_\_\_

148) Site where starch digestion begins

B) large intestine

148) \_\_\_\_\_

C)  
small intestine

D) stomach

*Match the following terms or phrases with the appropriate nutrient:*

149) Triglycerides

A) lipids

149) \_\_\_\_\_

*Match the following nutrients with their associated digestive enzymes:*

150) Lactose

A) amylase

150) \_\_\_\_\_

151) Fat

B) bile

151) \_\_\_\_\_

152) Starch

C) pepsinogen

152) \_\_\_\_\_

D)  
lactase

E) lipase

*Match the following terms or phrases with the appropriate nutrient:*

153) Fiber

A) carbohydrates

153) \_\_\_\_\_

*Identify the digestive organ that is primarily associated with the following digestive function:*

154) Primary site of water absorption

A) large intestine

154) \_\_\_\_\_

B)  
small intestine

*Match the following terms or phrases with the appropriate nutrient:*

155) Calcium, phosphorus, potassium

A) minerals

155) \_\_\_\_\_

**ESSAY. Write your answer in the space provided or on a separate sheet of paper.**

156) Explain what vitamins and minerals are and identify their importance to the body.

157) Describe the four layers of the GI tract.

158) Explain the various processes of food propulsion.

159) Discuss the anaerobic and aerobic mechanisms by which body cells generate adenosine triphosphate (ATP).

160) Identify and describe the six major processes involved in gastrointestinal activity.

161) Explain the role of the hormones cholecystokinin and secretin in regulating the release of bile and pancreatic juices.

162) Explain why there is really no such thing as "good" or "bad" lipoprotein cholesterol.

- 1) E
- 2) A
- 3) D
- 4) C
- 5) D
- 6) E
- 7) B
- 8) E
- 9) E
- 10) A
- 11) D
- 12) D
- 13) B
- 14) B
- 15) A
- 16) E
- 17) C
- 18) D
- 19) D
- 20) E
- 21) B
- 22) B
- 23) B
- 24) E
- 25) D
- 26) B
- 27) D
- 28) C
- 29) B
- 30) B
- 31) D
- 32) D
- 33) A
- 34) B
- 35) A
- 36) D
- 37) C
- 38) B
- 39) C
- 40) E
- 41) B
- 42) E
- 43) B
- 44) E
- 45) B
- 46) A
- 47) A
- 48) D
- 49) B
- 50) D
- 51) D

52) C  
53) E  
54) C  
55) E  
56) C  
57) gingiva (or gum)  
58) L  
59) glycogenesis  
60) O  
61) pancreatic juice  
62) medulla  
63) F  
64) ingestion  
65) pyloric  
66) M  
67) cardioesophageal  
68) low-density lipoprotein (LDL)  
69) rugae  
70) catabolism  
71) liver  
72) alcohol; aspirin  
73) N  
74) A  
75) gastrin  
76) small intestine  
77) kilocalories (kcal)  
78) lacteal  
79) B  
80) D  
81) K  
82) defecation reflex  
83) essential  
84) defecation  
85) cementum  
86) emulsification  
87) esophagus  
88) acetic acid  
89) Krebs cycle  
90) fundus  
91) H  
92) parietal peritoneum  
93) chyme  
94) E  
95) total metabolic rate  
96) I  
97) anus  
98) deciduous teeth  
99) pyrogens  
100) glucose  
101) J  
102) goblet cells  
103) ileum

- 104) mucosa
- 105) G
- 106) FALSE
- 107) FALSE
- 108) FALSE
- 109) FALSE
- 110) FALSE
- 111) FALSE
- 112) FALSE
- 113) TRUE
- 114) TRUE
- 115) TRUE
- 116) TRUE
- 117) TRUE
- 118) TRUE
- 119) TRUE
- 120) TRUE
- 121) TRUE
- 122) TRUE
- 123) FALSE
- 124) FALSE
- 125) FALSE
- 126) FALSE
- 127) FALSE
- 128) TRUE
- 129) TRUE
- 130) TRUE
- 131) FALSE
- 132) TRUE
- 133) TRUE
- 134) FALSE
- 135) FALSE
- 136) TRUE
- 137) FALSE
- 138) B
- 139) A
- 140) B
- 141) D
- 142) B
- 143) A
- 144) A
- 145) B
- 146) A
- 147) B
- 148) A
- 149) A
- 150) A
- 151) B
- 152) A
- 153) A
- 154) A
- 155) A

- 156) Vitamins are water-soluble, fat-soluble, or organic nutrients that the body requires in small amounts. Most function as coenzymes that enable an enzyme to accomplish a particular type of catalysis. Vitamins are found in all major food groups, and a balanced diet is the best way to ensure a full vitamin complement. Minerals are inorganic substances, such as calcium, potassium, and sodium, that the body also requires in adequate supply. The foods highest in mineral content are vegetables, legumes, milk, and some meats.
- 157) 1. Mucosa is the moist innermost layer; it lines the cavity of the organ.  
2. The submucosa is found beneath the mucosa layer. It contains blood vessels, nerve endings, lymph nodules, and lymphatic vessels.  
3. The muscular externis is the next layer, which is typically made up of a circular and a longitudinal layer of smooth muscle.  
4. The outermost layer is the serosa, which consists of two single layers of cells. The innermost serosa is the visceral peritoneum while the outermost layer is the parietal peritoneum. Between these layers is serous fluid.
- 158) Deglutition (swallowing) includes two phases, one voluntary and one involuntary. The voluntary phase is called the buccal phase, and it involves movement of the food bolus by the tongue into the pharynx. The involuntary phase is called the pharyngeal-esophageal phase, and it involves blockage of all routes except the esophageal route while the bolus is moved through the pharynx and into the esophagus. This reflex is regulated by the parasympathetic nervous system. Peristalsis is the rhythmic, wavelike motion of the stomach and intestines. It involves waves of contraction that move chyme along, followed by waves of relaxation. Another mechanism of food propulsion is segmentation of the small intestine. Although its chief function is mixing chyme with digestive juices, it also assists in propulsion. Mass movements are another mechanism by which food is moved through the GI tract, which occur three to four times a day, typically just after eating. They are powerful contractions that move over the colon and force contents toward the rectum to be stored until defecation. The presence of feces in the rectum initiates the defecation reflex, which causes the walls of the sigmoid colon and rectum to contract while relaxing the anal sphincters.
- 159) Cellular respiration includes all of the oxygen-dependent processes by which energy from the breakdown of glucose is captured within chemical bonds which unite adenosine diphosphate (ADP) and inorganic phosphate into the body's preferred metabolic fuel, adenosine triphosphate (ATP). One process, glycolysis, energizes each glucose molecule so that it can be split into two pyruvic acid molecules to yield ATP. The Krebs cycle, located within the mitochondria, produces all the carbon dioxide and water that results during cellular respiration, and it yields a small amount of ATP as well. The electron transport chain, also located within the mitochondria, is the primary producer of ATP. Hydrogen atoms removed during glycolysis and the Krebs cycle are delivered to the protein carriers of the electron transport chain, which form part of the mitochondrial cristae membranes. There the hydrogen atoms are split into their positive ions and negative electrons. The electrons then travel from carrier to carrier in a series of steps that enable phosphate to attach to ADP to form ATP.
- 160) Ingestion is the active, voluntary process of placing food into the mouth. Propulsion involves all of the actions involved in moving food along the alimentary canal from the mouth to the anus, including swallowing, peristalsis, segmentation, and mass movements. Mechanical digestion involves all of the activities that break food down into smaller pieces to prepare them for further degradation by enzymes. Chemical digesting, the next step of food breakdown, involves the sequence of steps by which large food molecules are broken down to their building blocks by enzymes. Absorption is the mechanism by which digested end products are moved from the lumen of the GI tract into the blood or lymph. The final process is defecation, which is the elimination of indigestible substances from the body via the anus as feces.
- 161) When chyme enters the small intestine, it stimulates the mucosa cells to produce the hormones cholecystokinin and secretin. These hormones travel in the bloodstream to their target organs: the pancreas, liver, and gallbladder. The pancreas responds to cholecystokinin by releasing enzyme-rich pancreatic juice and secretin causes the secretion of bicarbonate-rich pancreatic juice. The liver responds to secretin by releasing bile while cholecystokinin stimulates the gallbladder to release stored bile.
- 162) Lipoproteins transport cholesterol and fatty acids. Low-density lipoproteins (LDLs) transport cholesterol and other lipids to body cells for use in a variety of ways. If there are large amounts of circulating LDLs, some fatty substances may be deposited on arterial walls, which is the reason they are associated with heart disease risk and have sometimes been labeled "bad." However, they are a necessary transport substance, so the key is to have LDLs in the acceptable range. High-density lipoproteins (HDLs) transport cholesterol from the tissue cells or arteries to

the liver for disposal in bile. Because they transport cholesterol away from the arteries, they have sometimes been labeled "good." Again, they are a necessary transport substance, and the key is to have HDLs in the proper ratio with the LDLs, so that whatever excess cholesterol is moved in by the LDLs can be moved out again by the HDLs. It is their relative ratio that is important. Both are necessary, and neither should be considered "good" nor "bad."



Exam

Name \_\_\_\_\_

**MULTIPLE CHOICE. Choose the one alternative that best completes the statement or answers the question.**

- 1) In contrasting urine and filtrate by the time it reaches the collecting ducts, it could be said that: 1) \_\_\_\_\_
  - A) filtrate contains almost everything that blood plasma does
  - B) they contain essentially the same concentration of nutrients
  - C) urine contains almost everything that blood plasma does
  - D) filtrate contains more unnecessary substances than urine does
  - E) they contain essentially the same amount of water
  
- 2) The most potent of all mechanisms and substances that the body uses to regulate blood pH are: 2) \_\_\_\_\_
  - A) the respiratory system controls
  - B) the buffer system
  - C) hormones
  - D) the kidneys
  - E) enzymes
  
- 3) Which one of the following terms describes the location of the kidneys: 3) \_\_\_\_\_
  - A) retroperineal
  - B) suprarenal
  - C) intraperitoneal
  - D) retroperitoneal
  - E) adrenal
  
- 4) The chemical buffer system that includes carbonic acid and its salt, which ties up the  $H^+$  released by strong acids, is called the: 4) \_\_\_\_\_
  - A) ionic buffer system
  - B) carbonic buffer system
  - C) protein buffer system
  - D) phosphate buffer system
  - E) bicarbonate buffer system
  
- 5) Functional kidneys develop within the womb by the third month after conception from the \_\_\_\_\_ set of tubule systems. 5) \_\_\_\_\_
  - A) fourth
  - B) second
  - C) fifth
  - D) third
  - E) first
  
- 6) The degenerative condition in which blisterlike sacs (cysts) containing urine form on the kidneys and obstruct urine drainage is called: 6) \_\_\_\_\_
  - A) hypospadias
  - B) polycystic kidney
  - C) cystitis
  - D) dysuria
  - E) epispadias
  
- 7) The enlarged, cup-shaped closed end of the renal tubule that completely surrounds the glomerulus is called the: 7) \_\_\_\_\_
  - A) Bowman's capsule
  - B) distal convoluted tubule
  - C) proximal convoluted tubule
  - D) collecting duct
  - E) loop of Henle

- 8) Of the capillary beds associated with each nephron, the one that is both fed and drained by arterioles is the: 8) \_\_\_\_\_
- A) glomerulus
  - B) Henle capillaries
  - C) pyramidal capillaries
  - D) Bowman's capillaries
  - E) peritubular capillaries
- 9) Enlargement of the prostate that surrounds the neck of the bladder in adult men is called \_\_\_\_\_, which may cause voiding difficulty. 9) \_\_\_\_\_
- A) eutrophy
  - B) dystrophy
  - C) hypoplasia
  - D) atrophy
  - E) hyperplasia
- 10) Which one of the following is NOT a substance typically reabsorbed by the tubules under normal healthy conditions: 10) \_\_\_\_\_
- A) sodium
  - B) water
  - C) urea
  - D) glucose
  - E) amino acids
- 11) Which one of the following is NOT true of urine under normal healthy conditions: 11) \_\_\_\_\_
- A) it is sterile
  - B) it typically contains ammonia
  - C) it is slightly aromatic
  - D) it is slightly alkaline
  - E) it is more dense than water
- 12) Which one of the following substances is normally found in urine: 12) \_\_\_\_\_
- A) creatinine
  - B) red blood cells
  - C) blood proteins
  - D) hemoglobin
  - E) white blood cells
- 13) In one 24-hour period, the kidneys of an average-sized healthy adult filter approximately \_\_\_\_\_ through their glomeruli into the tubules. 13) \_\_\_\_\_
- A) 50-75 liters of blood plasma
  - B) 10-15 liters of blood plasma
  - C) 100-125 liters of blood plasma
  - D) 200-240 liters of blood plasma
  - E) 150-180 liters of blood plasma
- 14) Antidiuretic hormone prevents excessive water loss by promoting water reabsorption in the: 14) \_\_\_\_\_
- A) distal convoluted tubule
  - B) collecting duct
  - C) glomerulus
  - D) proximal convoluted tubule

E) bladder

- 15) Urine is transported from the bladder to the outside of the body by the: 15) \_\_\_\_\_  
A) prostate gland  
B) ureter  
C) urethra  
D) trigone  
E) collecting duct
- 16) The triangular regions of the kidneys that are striped in appearance and separated by the renal columns are the: 16) \_\_\_\_\_  
A) renal pyramids  
B) calyces  
C) renal cortex  
D) renal medulla  
E) renal pelvis
- 17) The noninvasive treatment for kidney stones that uses ultrasound waves to shatter calculi is called: 17) \_\_\_\_\_  
A) lithotomy  
B) lithotripsy  
C) lithiasis  
D) lithoscopy  
E) lithectomy
- 18) Which one of the following is NOT one of the major roles of the kidneys in normal healthy adults: 18) \_\_\_\_\_  
A) excretion of nitrogen-containing wastes  
B) ensuring proper blood pH  
C) maintenance of water balance of the blood  
D) maintenance of electrolyte balance of the blood  
E) conversion of ammonia to bicarbonate ion
- 19) The percentage of filtrate eventually reabsorbed into the bloodstream is closest to: 19) \_\_\_\_\_  
A) 50%                      B) 99%                      C) 10%                      D) 80%                      E) 25%
- 20) Which one of the following is NOT one of the functions of the kidneys: 20) \_\_\_\_\_  
A) produce hormones that assist in digestion  
B) manufacture urine  
C) dispose of metabolic waste products  
D) convert vitamin D from its inactive to its active form  
E) regulate blood volume
- 21) The bladder is able to expand as urine accumulates within it due to the presence of: 21) \_\_\_\_\_  
A) segmentation  
B) transitional epithelium  
C) sphincters  
D) pseudostratified epithelium  
E) rugae
- 22) The portion of the renal tubule that completely surrounds the glomerulus is the: 22) \_\_\_\_\_  
A) proximal convoluted tubule (PCT)

- B) loop of Henle
- C) distal convoluted tubule (DCT)
- D) collecting duct
- E) glomerular (Bowman's) capsule

- 23) Control of the voluntary urethral sphincter in normal children is related to: 23) \_\_\_\_\_
- A) hormone regulation
  - B) nervous system development
  - C) enzymatic regulation
  - D) muscular development
  - E) intelligence
- 24) Uric acid, a nitrogenous waste product, results from the metabolism of: 24) \_\_\_\_\_
- A) amino acids
  - B) proteins
  - C) nucleic acids
  - D) creatinine
  - E) salt
- 25) When blood pH begins to rise, the respiratory control centers in the brain are: 25) \_\_\_\_\_
- A) controlled by the kidneys
  - B) not effected
  - C) shut off
  - D) depressed
  - E) accelerated
- 26) A simple rule concerning water and electrolyte regulation is: 26) \_\_\_\_\_
- A) salt actively follows water
  - B) water passively follows salt
  - C) salt passively follows water
  - D) water actively follows salt
  - E) potassium passively follows sodium
- 27) The peritubular capillaries arise from the \_\_\_\_\_, which drains the glomerulus. 27) \_\_\_\_\_
- A) loop of Henle
  - B) Bowman's capsule
  - C) afferent arteriole
  - D) efferent arteriole
  - E) glomerulus
- 28) The nonselective, passive process performed by the glomerulus that forms blood plasma without blood proteins is called: 28) \_\_\_\_\_
- A) filtration
  - B) glomerular reabsorption
  - C) tubular reabsorption
  - D) secretion
  - E) absorption
- 29) Hypospadias is a condition of male children that involves: 29) \_\_\_\_\_
- A) atrophied prostate
  - B) opening of the urethra on the ventral surface of the penis
  - C) inflammation of the glomerulus

- D) closing of the foreskin over the end of the penis
- E) cysts on the kidneys

- 30) The average adult bladder is moderately full with \_\_\_\_\_ of urine within it. 30) \_\_\_\_\_  
A) 2 liters            B) 1 gallon            C) 1 liter            D) 100 mL            E) 500 mL
- 31) Each kidney contains about: 31) \_\_\_\_\_  
A) 100,000 nephrons  
B) 2 million nephrons  
C) 500,000 nephrons  
D) 1 million nephrons  
E) 3 million nephrons
- 32) The chemically buffered combination of strong acids that dissociate completely in water with weak bases such as hydroxides leads to a: 32) \_\_\_\_\_  
A) weak acid and a strong base  
B) weak acid and a salt  
C) weak base and salt  
D) strong base and a salt  
E) weak base and water
- 33) Which one of the following is NOT true of incontinence: 33) \_\_\_\_\_  
A) it is normal in older children who sleep soundly  
B) it occurs when we are unable to voluntarily control the external sphincter  
C) it is normal in children 2 years old or younger  
D) it can result from pressure on the bladder  
E) it is never considered normal
- 34) The main hormone that acts on the kidneys to regulate sodium ion concentration of the extracellular fluid (ECF) is: 34) \_\_\_\_\_  
A) epinephrine  
B) secretin  
C) renin  
D) aldosterone  
E) ADH
- 35) Extracellular fluid is found everywhere in the body EXCEPT: 35) \_\_\_\_\_  
A) blood plasma  
B) humors of the eye and lymph  
C) cerebrospinal fluid  
D) within living cells  
E) interstitial fluid
- 36) The process of emptying the bladder is referred to as voiding or: 36) \_\_\_\_\_  
A) tubular secretion  
B) micturition  
C) filtration  
D) incontinence  
E) tubular reabsorption
- 37) The proper pH for the blood is: 37) \_\_\_\_\_  
A) 6.8-6.9            B) 7.0-7.35            C) 7.35-7.45            D) 7.5-8.0            E) 6.5-8.0

- 38) Which of the following is NOT an organ found in the urinary system: 38) \_\_\_\_\_
- A) ureter
  - B) urethra
  - C) pancreas
  - D) kidney
  - E) urinary bladder
- 39) The results of the renin-angiotensin mechanism mediated by the juxtaglomerular apparatus of the renal tubules include all of the following EXCEPT: 39) \_\_\_\_\_
- A) increased peripheral resistance
  - B) blood pressure increase
  - C) blood volume increase
  - D) suppression of aldosterone
  - E) vasoconstriction
- 40) When carbon dioxide enters the blood from tissue cells, it is converted to \_\_\_\_\_ for transport within blood plasma. 40) \_\_\_\_\_
- A) sodium bicarbonate
  - B) bicarbonate ion
  - C) carbonic anhydrase
  - D) sodium hydroxide
  - E) ammonia
- 41) The tube connecting the renal hilus of the kidney to the bladder is the: 41) \_\_\_\_\_
- A) collecting duct
  - B) urethra
  - C) distal convoluted tubule
  - D) ureter
  - E) proximal convoluted tubule
- 42) The presence of pus in urine is called: 42) \_\_\_\_\_
- A) pyuria
  - B) bilirubinuria
  - C) glycosuria
  - D) hematuria
  - E) proteinuria
- 43) From childhood through late middle age, one of the most common bacteria to infect and inflame the urinary tract and cause urethritis and cystitis is: 43) \_\_\_\_\_
- A) streptococcus
  - B) *Clostridium botulinum*
  - C) *Escherichia coli*
  - D) staphylococcus
  - E) *Mycobacterium tuberculosis*
- 44) The kidneys are aided in the excretion of fluids by the: 44) \_\_\_\_\_
- A) skin
  - B) skin and hair
  - C) lungs and skin
  - D) hair
  - E) lungs

- 45) Most nephrons are located within the renal: 45) \_\_\_\_\_  
A) pyramids      B) medulla      C) calyces      D) pelvis      E) cortex
- 46) In a healthy young adult female, water accounts for: 46) \_\_\_\_\_  
A) less than one-half of body weight  
B) 99% of body weight  
C) approximately one-half of body weight  
D) three-quarters of body weight  
E) one-quarter of body weight
- 47) The voluntarily controlled sphincter fashioned by skeletal muscle at the point where the urethra passes through the pelvic floor is called the: 47) \_\_\_\_\_  
A) trigone  
B) internal anal sphincter  
C) external urethral sphincter  
D) detrusor sphincter  
E) internal urethral sphincter
- 48) Dilute urine would have a specific gravity closest to: 48) \_\_\_\_\_  
A) 1.010      B) 1.020      C) 1.001      D) 0.005      E) 1.030
- 49) Starting from the glomerular capsule, the correct order of the renal tubule regions is: 49) \_\_\_\_\_  
A) proximal convoluted tubule, loop of Henle, distal convoluted tubule  
B) distal convoluted tubule, loop of Henle, proximal convoluted tubule  
C) distal convoluted tubule, proximal convoluted tubule, loop of Henle  
D) loop of Henle, proximal convoluted tubule, distal convoluted tubule  
E) proximal convoluted tubule, distal convoluted tubule, loop of Henle
- 50) The average output of urine for a normal healthy adult is: 50) \_\_\_\_\_  
A) 1500 mL/day  
B) 2500 mL/day  
C) 500 mL/day  
D) 2000 mL/day  
E) 1000 mL/day
- 51) As venous blood is drained from the kidney, which path does it follow: 51) \_\_\_\_\_  
A) cortical radiate veins, arcuate veins, interlobar veins, renal vein  
B) arcuate veins, cortical radiate veins, interlobar veins, renal vein  
C) renal vein, segmental veins, interlobar veins, arcuate veins, cortical radiate veins  
D) renal vein, interlobar veins, segmental veins, arcuate veins  
E) cortical radiate veins, arcuate veins, interlobar veins, segmental veins, renal vein

**SHORT ANSWER. Write the word or phrase that best completes each statement or answers the question.**

*Fill in the blank or provide a short answer:*

- 52) Voiding, urination, and \_\_\_\_\_ are terms that indicate the passage of urine from the bladder. 52) \_\_\_\_\_

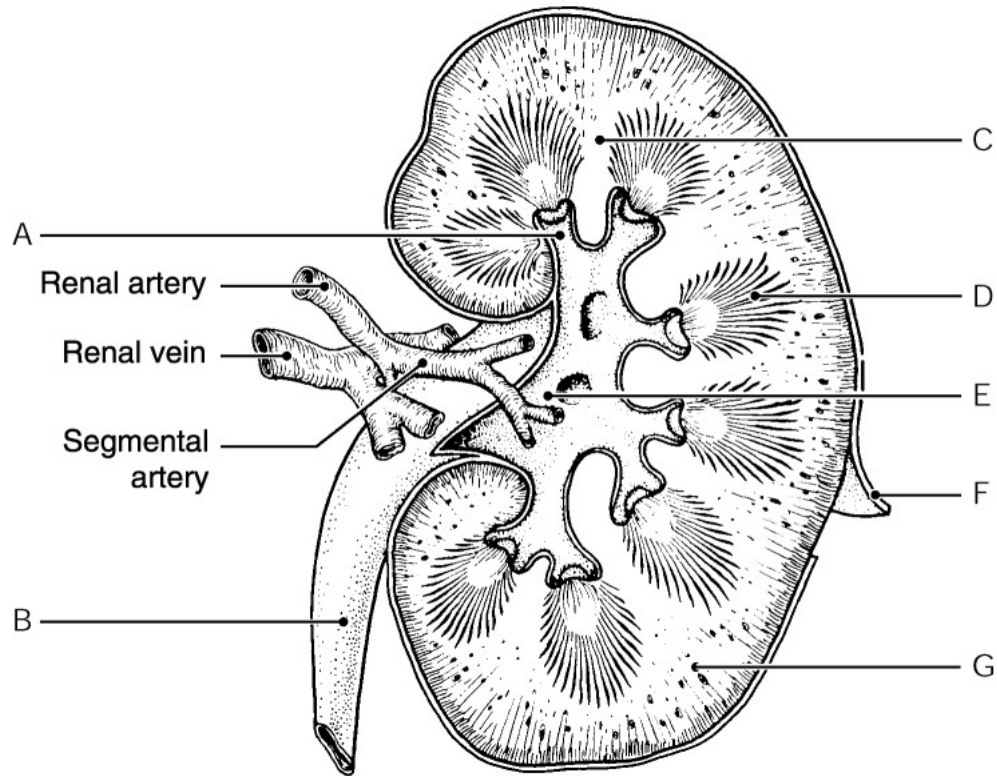

Figure 15.1

Using Figure 15.1, identify the following:

53) The ureter is indicated by letter \_\_\_\_\_ 53) \_\_\_\_\_

Fill in the blank or provide a short answer:

54) The need to urinate frequently at night, which plagues over 50% of the elderly, is called \_\_\_\_\_ 54) \_\_\_\_\_

55) The abnormal condition that results from the lack of ADH release, causing huge amounts of very dilute urine to be voided, is called \_\_\_\_\_ 55) \_\_\_\_\_

56) Another term for kidney stones, which form when urine becomes extremely concentrated, is \_\_\_\_\_ 56) \_\_\_\_\_

57) A feeling that it is necessary to void, which is experienced more regularly in the elderly, is known as \_\_\_\_\_ 57) \_\_\_\_\_



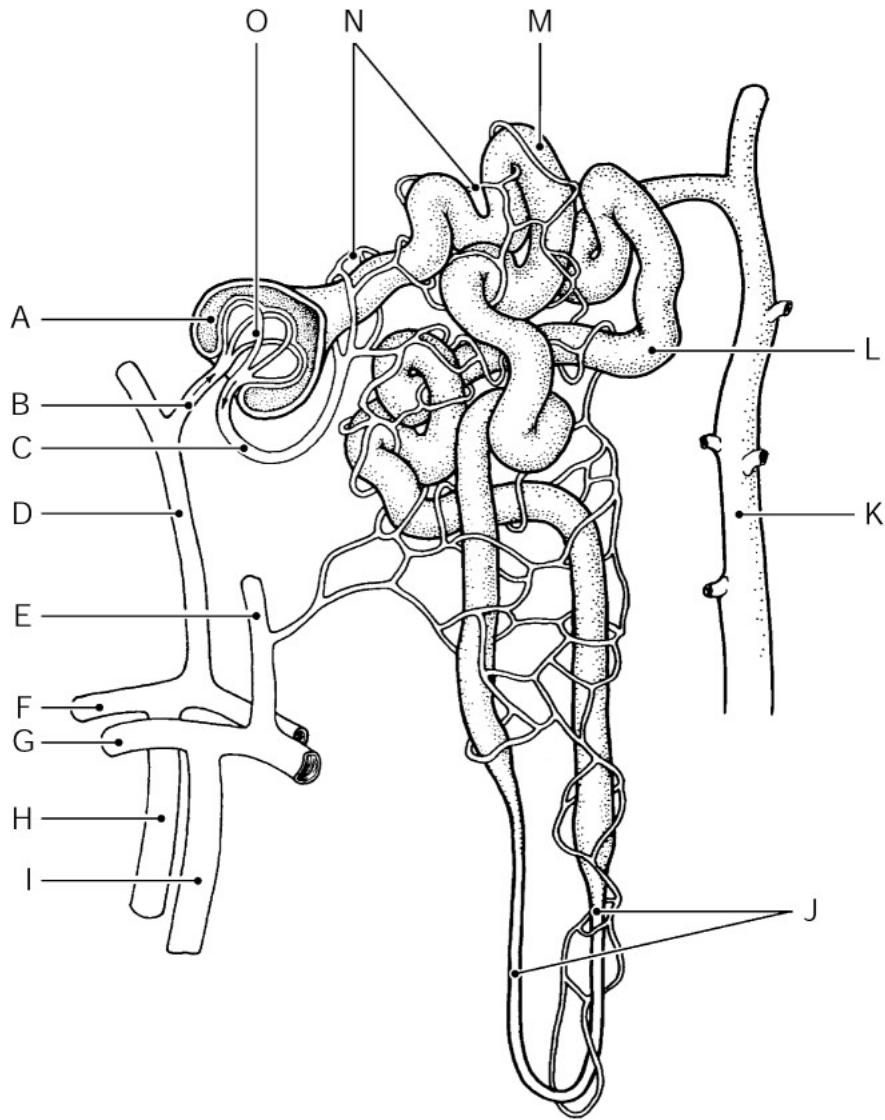

Figure 15.2

Using Figure 15.2, identify the following:

58) The arcuate vein is indicated by letter \_\_\_\_\_ 58) \_\_\_\_\_

Fill in the blank or provide a short answer:

59) The condition that results when red blood cells are abnormally present in urine is called \_\_\_\_\_ 59) \_\_\_\_\_

60) Each kidney is surrounded and held in place against the muscles of the trunk wall by its \_\_\_\_\_ 60) \_\_\_\_\_

61) A strong acid will dissociate and liberate more \_\_\_\_\_ ions in water than a weak acid. 61) \_\_\_\_\_

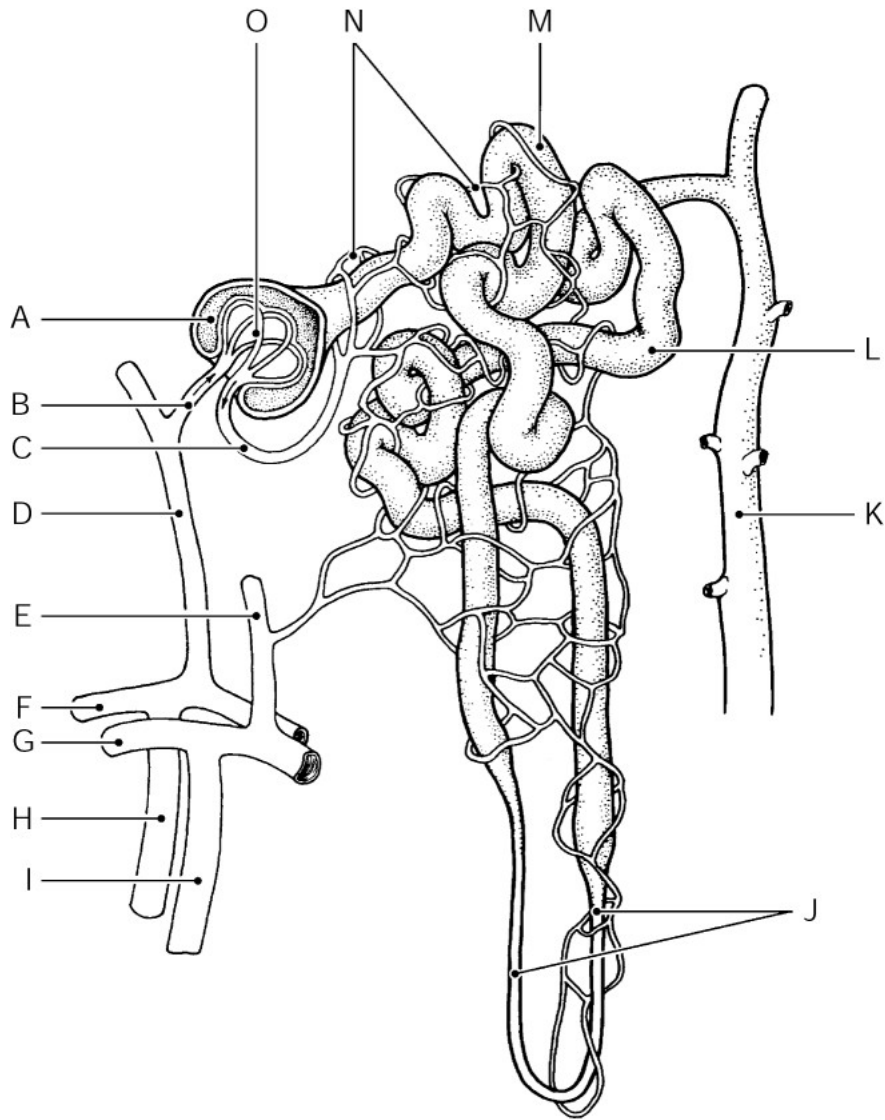

Figure 15.2

Using Figure 15.2, identify the following:

62) The glomerulus is indicated by letter \_\_\_\_\_.

62) \_\_\_\_\_

63) The glomerular capsule (Bowman's capsule) is indicated by letter \_\_\_\_\_.

63) \_\_\_\_\_

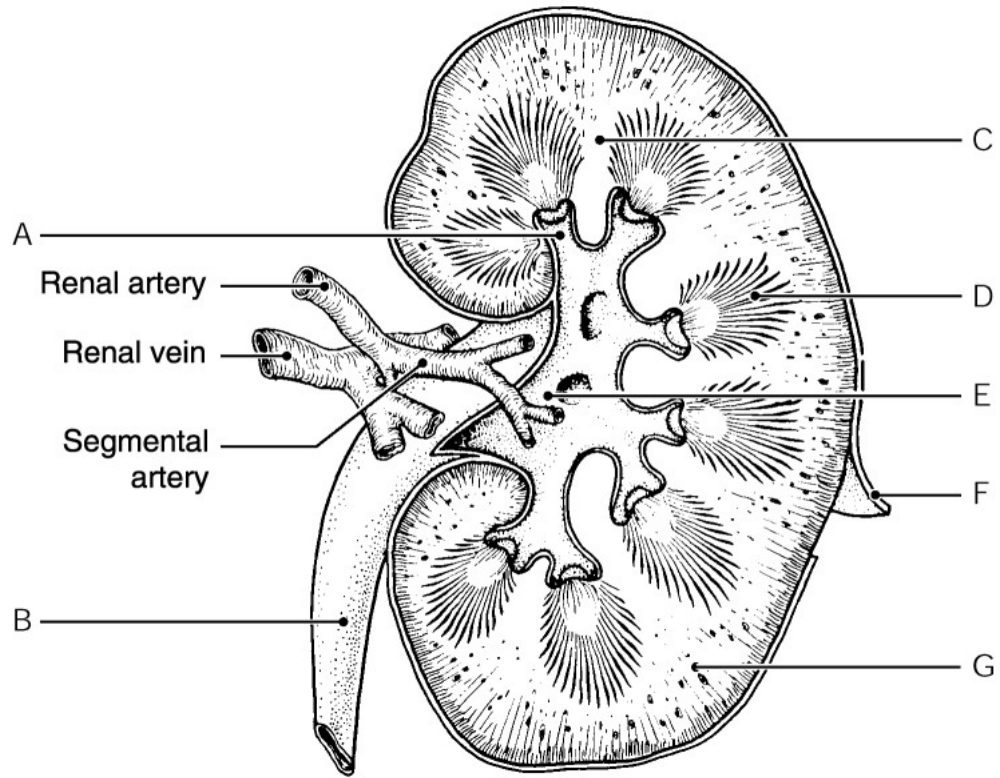

Figure 15.1

Using Figure 15.1, identify the following:

64) The renal pyramid is indicated by letter \_\_\_\_\_.

64) \_\_\_\_\_

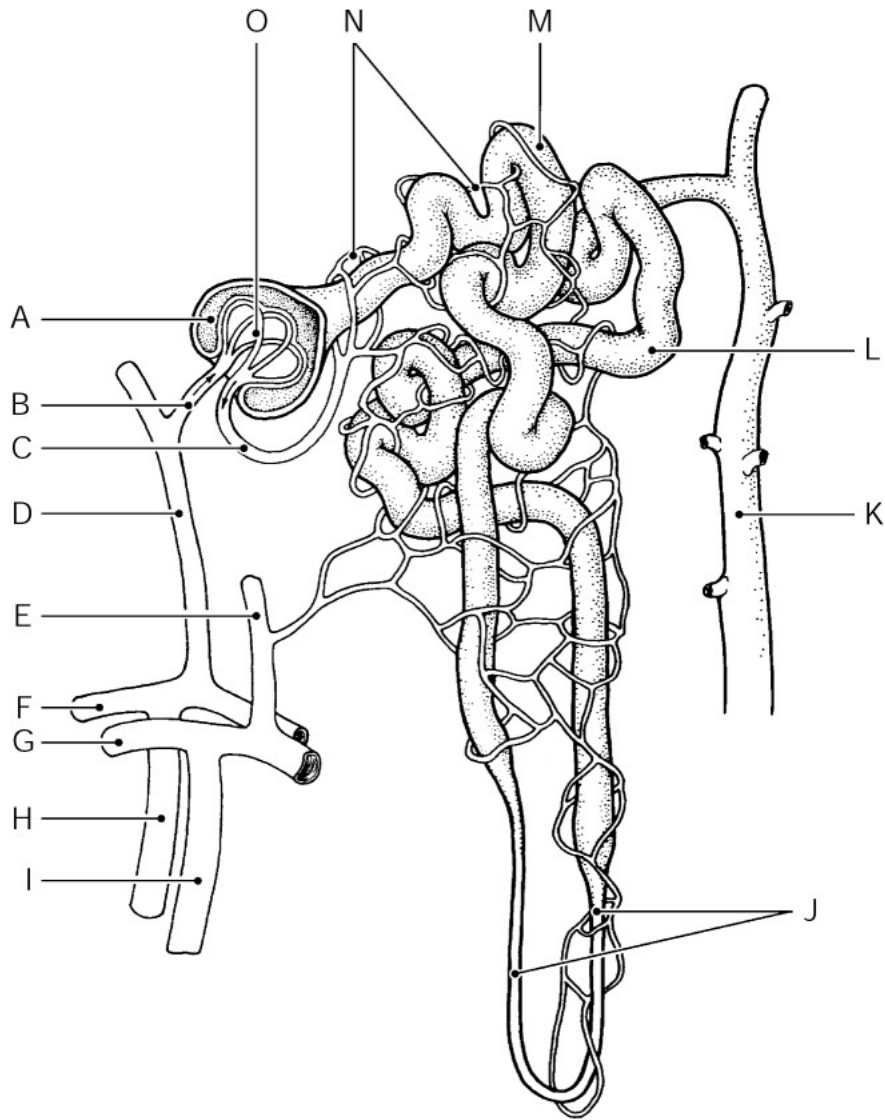

Figure 15.2

Using Figure 15.2, identify the following:

65) The proximal convoluted tubule is indicated by letter \_\_\_\_\_.

65) \_\_\_\_\_

Fill in the blank or provide a short answer:

66) Arterial blood pH between 7.35 and 7.0 is called \_\_\_\_\_.

66) \_\_\_\_\_

67) The process of filtration occurs in a specific structure in the nephron called the \_\_\_\_\_.

67) \_\_\_\_\_

68) There are three regions of the kidney; the outermost region is known as the \_\_\_\_\_.

68) \_\_\_\_\_

69) Untreated streptococcal infections in childhood that can lead to the kidney infection characterized by antigen-antibody complexes clogging the glomerular filters is known as \_\_\_\_\_.

69) \_\_\_\_\_

70) Highly sensitive cells within the hypothalamus that react to changes in blood composition and cause the release of antidiuretic hormone (ADH) when appropriate are called \_\_\_\_\_.

70) \_\_\_\_\_

71) Specific gravity is the term used to compare how much heavier urine is than \_\_\_\_\_. 71) \_\_\_\_\_

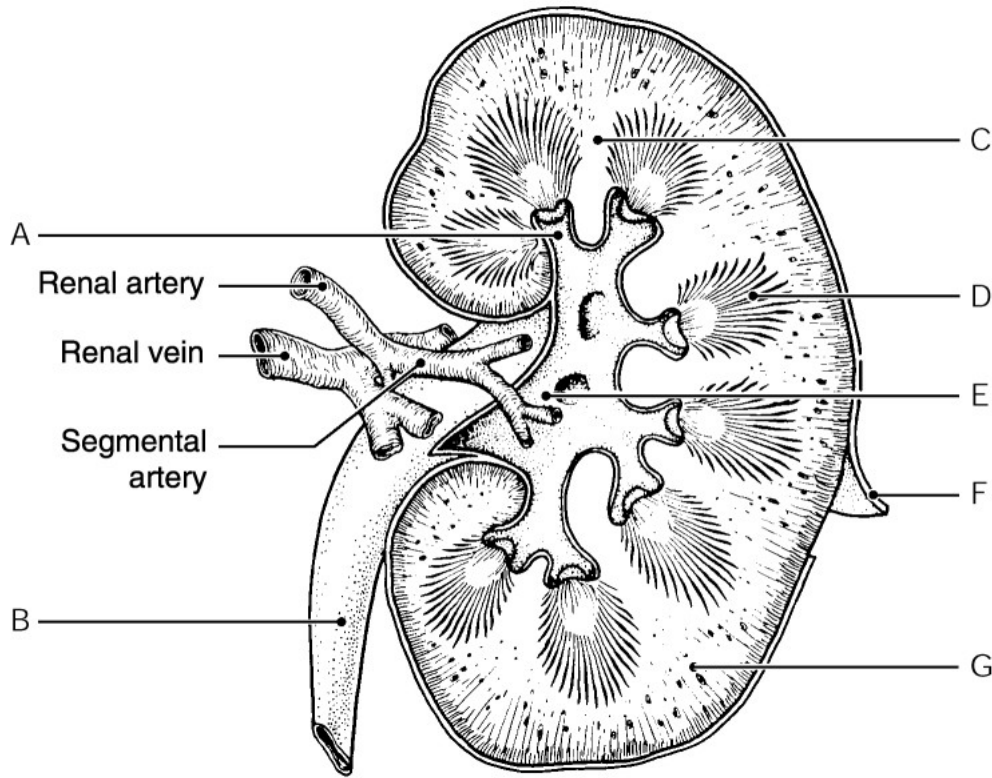

Figure 15.1

Using Figure 15.1, identify the following:

72) The fibrous capsule is indicated by letter \_\_\_\_\_. 72) \_\_\_\_\_

Fill in the blank or provide a short answer:

73) A vegetarian diet is said to be a(n) \_\_\_\_\_ diet because it makes urine extremely alkaline as the kidneys excrete excess bases. 73) \_\_\_\_\_

74) The inability to voluntarily control the external urethral sphincter is known as \_\_\_\_\_. 74) \_\_\_\_\_

75) About two-thirds of body fluid is found within living cells; this fluid is called the \_\_\_\_\_. 75) \_\_\_\_\_

76) The smooth triangular region of the bladder base that is outlined by the openings of the two ureters and the urethra is called the \_\_\_\_\_. 76) \_\_\_\_\_

77) As blood flows toward the kidney, it travels from the renal artery into vessels called the \_\_\_\_\_. 77) \_\_\_\_\_

78) Contrast the roles of the ureters and urethra in the urinary system. 78) \_\_\_\_\_

Fill in the blank or provide a short answer:

79) Renal pyramids are separated by extensions of cortex-like tissue called the \_\_\_\_\_. 79) \_\_\_\_\_

80) The involuntary sphincter that keeps the urethra closed when urine is not being passed is called the \_\_\_\_\_.

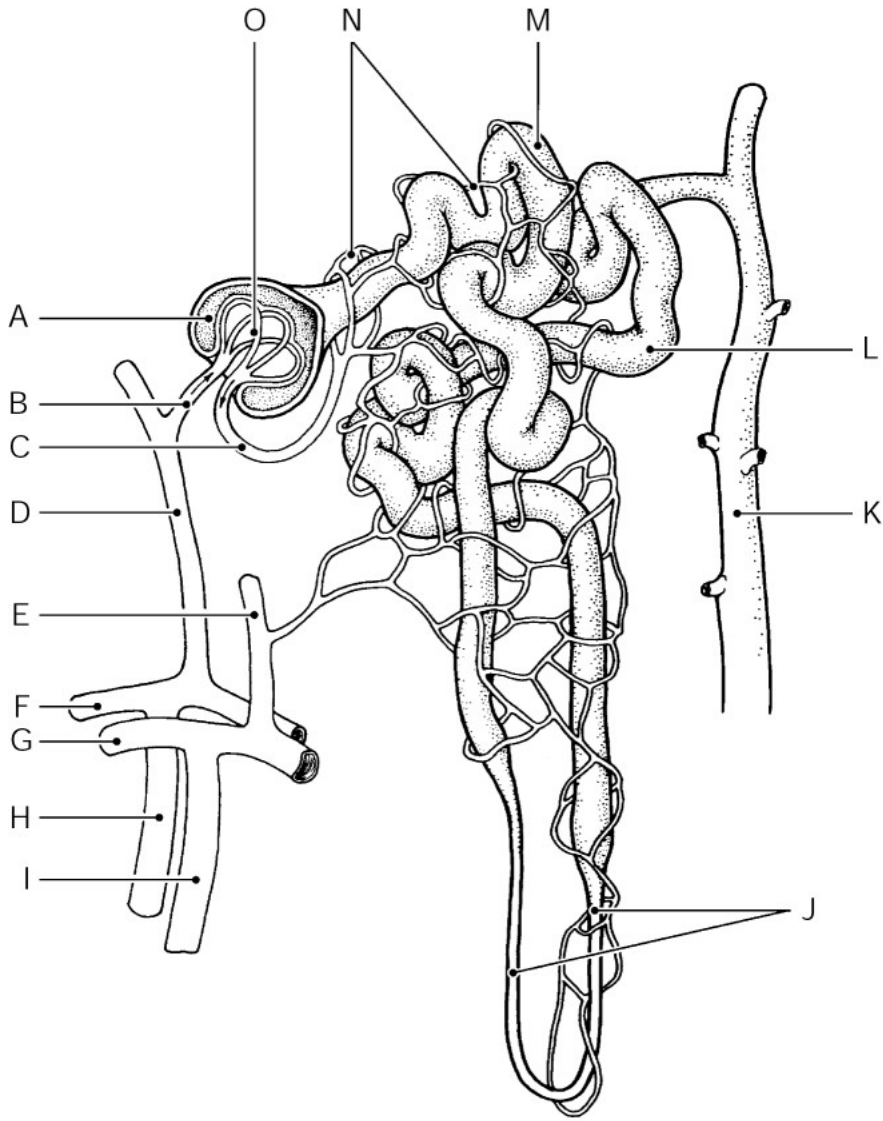

Figure 15.2

Using Figure 15.2, identify the following:

81) The collecting duct is indicated by letter \_\_\_\_\_.

81) \_\_\_\_\_

82) The loop of Henle is indicated by letter \_\_\_\_\_.

82) \_\_\_\_\_

Fill in the blank or provide a short answer:

83) The pigment resulting from the destruction of hemoglobin that gives freshly-voided urine its pale yellow color is called \_\_\_\_\_.

83) \_\_\_\_\_

84) The kidneys can help maintain a rising blood pH by excreting \_\_\_\_\_ ions and reabsorbing \_\_\_\_\_ ions by the tubule cells.

84) \_\_\_\_\_

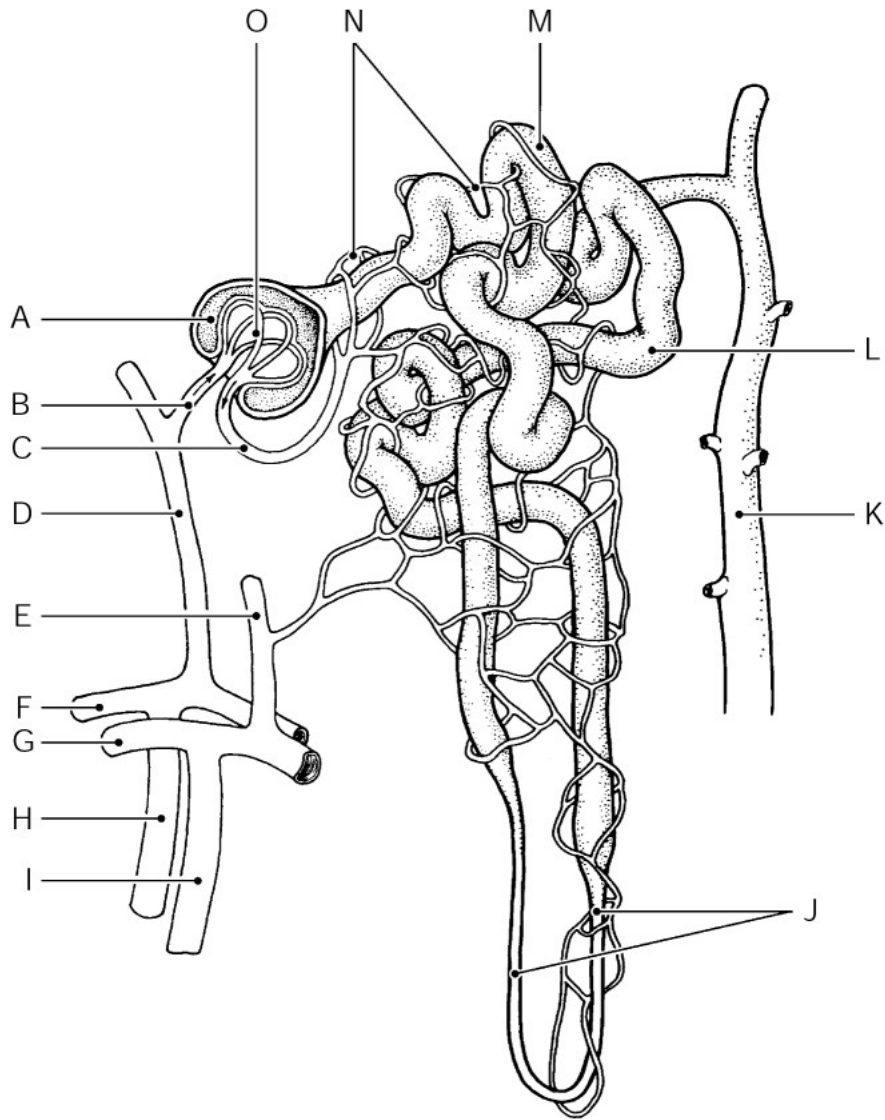

Figure 15.2

Using Figure 15.2, identify the following:

85) The afferent arteriole is indicated by letter \_\_\_\_\_.

85) \_\_\_\_\_

Fill in the blank or provide a short answer:

86) Urinary bladder inflammation often caused by bacterial infection is called \_\_\_\_\_.

86) \_\_\_\_\_

87) A urinary output of less than 100 mL per day is called \_\_\_\_\_.

87) \_\_\_\_\_

88) Sodium ion content of the extracellular fluid (ECF) is largely regulated by an adrenal cortex hormone called \_\_\_\_\_.

88) \_\_\_\_\_

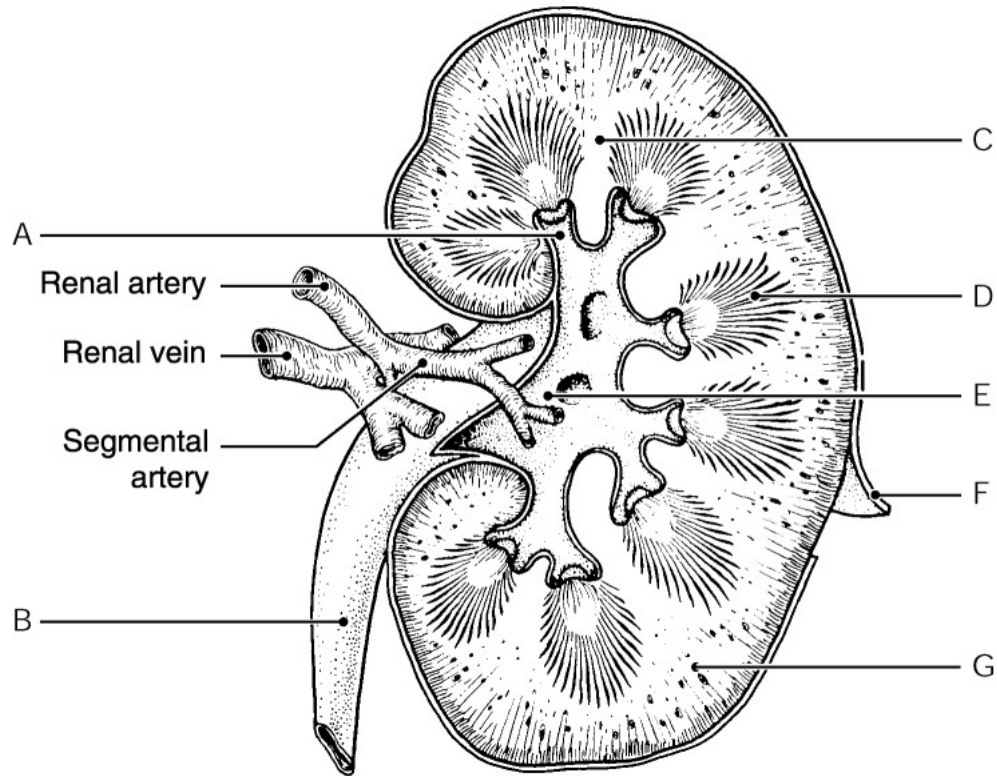

Figure 15.1

Using Figure 15.1, identify the following:

89) The renal column is indicated by letter \_\_\_\_\_. 89) \_\_\_\_\_

Fill in the blank or provide a short answer:

90) The primary urinary symptom of Addison's disease (hypoaldosteronism) is called \_\_\_\_\_. 90) \_\_\_\_\_

**TRUE/FALSE. Write 'T' if the statement is true and 'F' if the statement is false.**

91) Sexually transmitted diseases (STDs) are primarily infections of the reproductive tracts but may also cause urinary tract infections. 91) \_\_\_\_\_

92) The lumen surfaces of the tubule cells within the proximal convoluted tubule are covered with microvilli. 92) \_\_\_\_\_

93) Incontinence is often the final outcome of the urinary system during the aging process. 93) \_\_\_\_\_

94) Following the micturition reflex, it is impossible to postpone bladder emptying. 94) \_\_\_\_\_

95) Nitrogenous waste products such as urea, uric acid, and creatinine are excreted from the body in urine rather than reabsorbed. 95) \_\_\_\_\_

96) The fluid stored inside cells is referred to as extracellular fluid (ECF). 96) \_\_\_\_\_

97) Antidiuretic hormone (ADH) causes increased water loss through the urine. 97) \_\_\_\_\_

98) The specific gravity of urine is typically lower than the specific gravity of pure water. 98) \_\_\_\_\_



- 99) A person with arterial blood pH above 7.45 is said to have acidosis. 99) \_\_\_\_\_
- 100) The medial indentation of the kidney where several structures such as the ureters, renal blood vessels, and nerves enter and exit the kidney is called the hilus. 100) \_\_\_\_\_
- 101) Urine moves down the ureters into the bladder due to gravitational pull alone. 101) \_\_\_\_\_
- 102) The tiny filtering structures of the kidneys are called nephrons. 102) \_\_\_\_\_
- 103) When blood pH becomes too acidic, the tubule cells of the kidneys excrete bicarbonate ions and retain hydrogen ions. 103) \_\_\_\_\_
- 104) Blood proteins and blood cells are too large to pass through the filtration membrane and should not be found in filtrate. 104) \_\_\_\_\_
- 105) The movement of water from one fluid compartment to another has no effect on blood volume and blood pressure. 105) \_\_\_\_\_
- 106) The urethra, which carries urine exiting the bladder by peristalsis, is typically shorter in females than in males. 106) \_\_\_\_\_
- 107) The region of the renal tubule closest to the glomerular capsule is the distal convoluted tubule. 107) \_\_\_\_\_
- 108) The internal urethral sphincter is involuntary. 108) \_\_\_\_\_
- 109) Tubular secretion, which seems to be important for removal of substances not already in the filtrate, is essentially reabsorption in reverse. 109) \_\_\_\_\_
- 110) The pigment that gives urine its characteristic yellow color is urochrome. 110) \_\_\_\_\_
- 111) The peritubular capillary bed arises from the afferent arteriole. 111) \_\_\_\_\_
- 112) The most important trigger for aldosterone release is the renin-angiotensin mechanism, mediated by the renal tubules. 112) \_\_\_\_\_
- 113) The kidneys help maintain acid-base balance of the blood by excreting bicarbonate ions. 113) \_\_\_\_\_
- 114) Tubular reabsorption begins in the glomerulus. 114) \_\_\_\_\_

**MATCHING. Choose the item in column 2 that best matches each item in column 1.**

*Identify these organs of the urinary system with their associated descriptions:*

- |  |            |            |
|--|------------|------------|
| 115) Transports urine and sperm in males   | A) urethra | 115) _____ |
| 116) Contains an area called the trigone formed by the openings of the ureters and urethra | B) bladder | 116) _____ |

*Identify the substances within the urine and their possible causes with the name of the associated condition:*

- |   |           |    |                |
|---|-----------|----|----------------|
| 117) Hemoglobin in the urine due to hemolytic anemia or a transfusion | react ion | A) | hem a<br>aturi |
|---|-----------|----|----------------|

117) \_\_\_\_\_

- B) hemoglobinuria

*Identify these organs of the urinary system with their associated descriptions:*

- 118) Muscular sac suitable for temporary urine storage      A) bladder      118) \_\_\_\_\_

*Identify the urinary structure with its associated description:*

- 119) Vessels supplying each kidney with blood to be filtered      A) renal cortex      119) \_\_\_\_\_

- 120) Outer, lighter region of the kidney      B) renal vein      120) \_\_\_\_\_  
C) renal medulla  
D) renal artery

*Identify the substances within the urine and their possible causes with the name of the associated condition:*

- 121) Glucose in the urine due to diabetes mellitus      A) glycosuria      121) \_\_\_\_\_  
B) dysuria

*Identify these organs of the urinary system with their associated descriptions:*

- 122) Tube that drains urine from the kidney to the bladder      A) ureter      122) \_\_\_\_\_

*Identify the urinary structure with its associated description:*

- 123) Cortex-like extensions that separate the pyramids      A) renal cortex      123) \_\_\_\_\_

- 124) Flat, basinlike cavity medial to the hilus of the kidney      B) renal medulla      124) \_\_\_\_\_

- 125) Darker, reddish-brown internal area of the kidney      C) renal pelvis      125) \_\_\_\_\_  
D) renal columns

*Identify the substances within the urine and their possible causes with the name of the associated condition:*

- 126) Proteins in the urine due to pregnancy or excessive exercise      A) anuria      126) \_\_\_\_\_  
B) proteinuria

*Identify the urinary structure with its associated description:*

- 127) Cup-shaped extensions of the pelvis      A) pyramids      127) \_\_\_\_\_

- 128) Triangular regions with a striped appearance      B) renal

pyramid 128)

s

\_\_\_\_\_

-

C) calyces

*Identify the substances within the urine and their possible causes with the name of the associated condition:*

129) RBCs in the urine due to trauma or infection

A) pyuria

129) \_\_\_\_\_

130) Bile pigment in the urine due to hepatitis

B) hematuria

130) \_\_\_\_\_

C) uremia

D) bilirubinuria

*Identify these organs of the urinary system with their associated descriptions:*

131) In males, this organ is surrounded by the prostate

A) bladder

131) \_\_\_\_\_

*Identify the substances within the urine and their possible causes with the name of the associated condition:*

132) Pus containing WBCs and bacteria in the urine due to urinary tract infection

A) uremia

132) \_\_\_\_\_

B) pyuria

*Identify these organs of the urinary system with their associated descriptions:*

133) Inflammation of this organ is called cystitis

A) bladder

133) \_\_\_\_\_

**ESSAY. Write your answer in the space provided or on a separate sheet of paper.**

134) Identify and describe the three major processes involved in urine formation.

135) Describe the normal characteristics of freshly-voided urine in a healthy adult.

136) Explain the renin-angiotensin mechanism.

137) Describe and explain urethral control and concepts related to incontinence.

138) Describe the bicarbonate buffer system and explain its importance in regulating pH changes.

- 1) A
- 2) D
- 3) D
- 4) E
- 5) D
- 6) B
- 7) A
- 8) A
- 9) E
- 10) C
- 11) D
- 12) A
- 13) E
- 14) B
- 15) C
- 16) A
- 17) B
- 18) E
- 19) B
- 20) A
- 21) B
- 22) E
- 23) B
- 24) C
- 25) D
- 26) B
- 27) D
- 28) A
- 29) B
- 30) E
- 31) D
- 32) B
- 33) E
- 34) D
- 35) D
- 36) B
- 37) C
- 38) C
- 39) D
- 40) B
- 41) D
- 42) A
- 43) C
- 44) C
- 45) E
- 46) C
- 47) C
- 48) C
- 49) A
- 50) A
- 51) A

- 52) micturition
- 53) B
- 54) nocturia
- 55) diabetes insipidus
- 56) renal calculi
- 57) urgency
- 58) G
- 59) hematuria
- 60) renal fascia
- 61) hydrogen ( $H^+$ )
- 62) O
- 63) A
- 64) D
- 65) M
- 66) physiological acidosis
- 67) glomerulus
- 68) renal cortex
- 69) glomerulonephritis
- 70) osmoreceptors
- 71) distilled water
- 72) F
- 73) alkaline-ash
- 74) incontinence
- 75) intracellular fluid (ICF)
- 76) trigone
- 77) segmental arteries
- 78) The ureters are tubes that connect the kidneys to the bladder. Each ureter transports urine to the bladder. Both gravity and peristalsis aid in the movement of urine.  
The urethra is a tube that transports urine from the bladder to the outside of the body. The passage of urine from the bladder into the urethra is controlled by two sphincters: the internal, involuntary sphincter and the external, voluntary sphincter.
- 79) renal columns
- 80) internal urethral sphincter
- 81) K
- 82) J
- 83) urochrome
- 84) bicarbonate; hydrogen
- 85) B
- 86) cystitis
- 87) anuria
- 88) aldosterone
- 89) C
- 90) polyuria
- 91) TRUE
- 92) TRUE
- 93) TRUE
- 94) FALSE
- 95) TRUE
- 96) FALSE
- 97) FALSE
- 98) FALSE
- 99) FALSE

- 100) TRUE
- 101) FALSE
- 102) TRUE
- 103) FALSE
- 104) TRUE
- 105) FALSE
- 106) TRUE
- 107) FALSE
- 108) TRUE
- 109) TRUE
- 110) TRUE
- 111) FALSE
- 112) TRUE
- 113) TRUE
- 114) FALSE
- 115) A
- 116) B
- 117) B
- 118) A
- 119) D
- 120) A
- 121) A
- 122) A
- 123) D
- 124) C
- 125) B
- 126) B
- 127) C
- 128) B
- 129) B
- 130) D
- 131) A
- 132) B
- 133) A
- 134) Filtration is a nonselective, passive process with the glomerulus acting as the filter. The filtrate formed is essentially blood plasma without blood proteins, which are too large to pass through the filtration membrane into the renal tubule. Reabsorption is the process by which the body reclaims substances within the filtrate that it wants to keep. Most reabsorption is an active process using membrane carriers. Substances that are typically reabsorbed include amino acids, glucose, and ions. Most reabsorption occurs in the proximal convoluted tubules. Secretion is the opposite process. With secretion, substances such as hydrogen ions, potassium ions, and creatinine are removed from the peritubular capillaries into the tubules to be eliminated in urine.
- 135) Urine is a pale, straw-colored liquid that progressively becomes a darker yellow color as it becomes more concentrated. The yellow color is a result of the presence of urochrome pigment, a by-product of hemoglobin breakdown. Urine is more dense than water with a specific gravity of 1.001 to 1.035. Urine is sterile and slightly aromatic and has an acidic pH of around 6. Urine normally contains sodium and potassium ions, urea, uric acid, creatinine, ammonia, and bicarbonate ions, as well as other ions the body needs to dispose of.
- 136) The renin-angiotensin mechanism is the most important trigger for the release of aldosterone. It is mediated by the juxtaglomerular (JG) apparatus of the renal tubules. The JG apparatus consists of modified smooth muscle cells that are stimulated by low blood pressure within the afferent arteriole or changes in solute content of the filtrate. The JG cells respond to these changes by releasing renin into the blood. Renin catalyzes reactions that lead to angiotensin II production, which then acts directly on the blood vessels to cause vasoconstriction as well as aldosterone release. Aldosterone then causes the reabsorption of sodium and water, leading to increased blood volume and blood

pressure.

- 137) The urethra contains two sphincters. The internal urethral sphincter is involuntary and is formed from a thickening of smooth muscle at the bladder-urethra junction. The second sphincter is the external urethral sphincter, made from skeletal muscle and under voluntary control. Control of the external urethral sphincter often develops at around 2 years of age. Prior to that time, the child is simply not able to control urination and is incontinent. Other causes for incontinence include emotional problems, pressure on the bladder, such as with pregnancy, stroke, spinal cord injury, and the aging process.
- 138) The bicarbonate buffer system is one of three major chemical buffer systems in normal humans. The buffer systems each help to maintain pH within the body's fluid compartments, and since they act within a fraction of a second, they are the first line of defense in resisting abnormal pH changes. The bicarbonate buffer system is a mixture of carbonic acid and sodium bicarbonate. Carbonic acid is a weak acid which remains relatively intact in the presence of a strong acid. Its salt, sodium bicarbonate, acts as a weak base in the presence of a strong acid, such as hydrochloric acid, tying up the  $H^+$  released and forming carbonic acid. Because the strong acid is changed to a weak acid, the pH of the solution is lowered slightly. If a strong base like sodium hydroxide is added to a solution containing the bicarbonate buffer system, sodium bicarbonate will not dissociate further, but carbonic acid will. More hydrogen ions will be released to bind with the hydroxyl ions, with the net result being the replacement of a strong base by a weak one. The pH of the solution will then rise slightly.

Exam

Name \_\_\_\_\_

**MULTIPLE CHOICE. Choose the one alternative that best completes the statement or answers the question.**

- 1) The primary germ layer that gives rise to the mucosae and associated glands is the: 1) \_\_\_\_\_  
A) blastocyst      B) morula      C) endoderm      D) ectoderm      E) mesoderm
  
- 2) Androgens such as testosterone are produced by the: 2) \_\_\_\_\_  
A) prostate  
B) interstitial cells  
C) bulbourethral glands  
D) seminiferous tubules  
E) epididymis
  
- 3) Pregnancy is generally improbable with a sperm count: 3) \_\_\_\_\_  
A) under 5 million per milliliter  
B) under 1 million per milliliter  
C) under 20 million per milliliter  
D) under 20,000 per milliliter  
E) under 100 million per milliliter
  
- 4) Many home pregnancy tests assay for \_\_\_\_\_ within a woman's urine. 4) \_\_\_\_\_  
A) luteinizing hormone  
B) testosterone  
C) estrogen  
D) human chorionic gonadotropin  
E) progesterone
  
- 5) The external female structure that corresponds to the male penis is the: 5) \_\_\_\_\_  
A) labia majora  
B) vagina  
C) perineum  
D) clitoris  
E) cervix
  
- 6) The hormone responsible for ovulation is: 6) \_\_\_\_\_  
A) progesterone  
B) adrenocorticotrophic hormone  
C) luteinizing hormone  
D) follicle-stimulating hormone  
E) estrogen
  
- 7) The tiny ball of 16 cells found freely floating in the uterine cavity is called a: 7) \_\_\_\_\_  
A) zygote  
B) placenta  
C) trophoblast  
D) morula  
E) blastocyte
  
- 8) The enlarged tip of the penis is referred to as the: 8) \_\_\_\_\_  
A) scrotum  
B) glans penis



- C) shaft
- D) prepuce
- E) spongy urethra

- 9) The superior rounded region of the uterus above the entrance of the uterine tubes is called the: 9) \_\_\_\_\_
- A) fundus
  - B) mons pubis
  - C) cervix
  - D) body
  - E) corpus
- 10) Menopause, which ends childbirth ability, is considered to have occurred when a woman: 10) \_\_\_\_\_
- A) has had a hysterectomy
  - B) misses two periods in a row
  - C) has gone a year without menstruation
  - D) misses her first period
  - E) turns 50
- 11) The inner mucosal layer of the uterus that is sloughed off approximately every 28 days is called the: 11) \_\_\_\_\_
- A) endometrium
  - B) hypometrium
  - C) epimetrium
  - D) perimetrium
  - E) myometrium
- 12) The primitive stem cell of spermatogenesis, which is found on the periphery of each seminiferous tubule, is called: 12) \_\_\_\_\_
- A) primary spermatocyte
  - B) secondary spermatocyte
  - C) spermatid
  - D) sperm
  - E) spermatogonia
- 13) The male gonads have both sperm-producing and testosterone-producing functions and are called: 13) \_\_\_\_\_
- A) ovaries
  - B) gametes
  - C) testes
  - D) ovum
  - E) sperm
- 14) Thick, clear mucus that cleanses the urethra of acidic urine is produced by the: 14) \_\_\_\_\_
- A) prostate
  - B) bulbourethral glands
  - C) epididymis
  - D) seminal vesicles
  - E) testes
- 15) All the organ systems are laid down, at least in rudimentary form, and the embryo looks distinctly human by the \_\_\_\_\_ of embryonic development. 15) \_\_\_\_\_
- A) first week
  - B) second week
  - C) fourth week
  - D) eighth week
  - E) twelfth week

- 16) The corpus luteum is a special glandular structure of the ovaries that primarily produces: 16) \_\_\_\_\_  
A) estrogen  
B) testosterone  
C) luteinizing hormone  
D) interstitial cell-stimulating hormone  
E) progesterone
- 17) The final outcome of meiosis within both the testicles and the ovaries is: 17) \_\_\_\_\_  
A) two gametes  
B) the formation of two identical daughter cells  
C) four gametes  
D) three gametes  
E) one gamete
- 18) The clusters of specific glands that produce milk when a woman is lactating are called: 18) \_\_\_\_\_  
A) alveolar glands  
B) lactiferous ducts  
C) areolar glands  
D) mammary glands  
E) lactating glands
- 19) Labor is initiated by prostaglandins and \_\_\_\_\_. 19) \_\_\_\_\_  
A) progesterone  
B) relaxin  
C) renin  
D) oxytocin  
E) human chorionic gonadotropin
- 20) Which one of the following is NOT true of the proliferative state of the menstrual cycle: 20) \_\_\_\_\_  
A) it is stimulated by rising estrogen levels  
B) the basal layer of the endometrium regenerates  
C) endometrial blood supply is increased  
D) the endometrium becomes thin and shiny in appearance  
E) glands are formed in the endometrium
- 21) The normal period of human gestation is calculated as \_\_\_\_\_ from the last menstrual period. 21) \_\_\_\_\_  
A) 280 days  
B) 9 calendar months  
C) 265 days  
D) 295 days  
E) 9 lunar months
- 22) The first menstrual period, which usually occurs at approximately age 13, is called: 22) \_\_\_\_\_  
A) menstruation  
B) menses  
C) menogen  
D) menarche  
E) menopause
- 23) The hormone produced by the placenta that causes the pelvic ligaments and pubic symphysis to relax,

widen, 23)  
and  
become  
more  
flexible  
to ease  
birth  
passage  
is called:

—  
—

- A) gonadotropin
- B) relaxin
- C) renin
- D) progesterone
- E) chorion

24) Normal healthy semen has an approximate pH level of: 24) \_\_\_\_\_  
A) 8.5–9.0      B) 7.2–7.6      C) 3.5–4      D) 4.0–5.7      E) 6.0–7.0

25) For a sperm cell to fertilize an ovum, sexual intercourse must occur no more than \_\_\_\_\_ 25) \_\_\_\_\_  
hours before ovulation.  
A) 72      B) 24      C) 12      D) 90      E) 48

26) Fertilization usually occurs in the: 26) \_\_\_\_\_  
A) uterine (fallopian) tubes  
B) uterus  
C) ovary  
D) vagina  
E) Graafian follicle

27) A fertilized egg is known as a: 27) \_\_\_\_\_  
A) morula  
B) zygote  
C) secondary oocyte  
D) blastocyte  
E) primary oocyte

28) Milky-colored fluid secreted from the prostate: 28) \_\_\_\_\_  
A) are endocrine only  
B) nourish sperm  
C) cleanse the urethra  
D) activate sperm  
E) neutralize urine

29) The exocrine function of the male testes is: 29) \_\_\_\_\_  
A) embryo nutrition  
B) testosterone production  
C) sperm production  
D) ovum fertilization  
E) estrogen production

30) For women aged 40–49, the American Cancer Society recommends mammography every 30) \_\_\_\_\_  
\_\_\_\_\_ to detect breast cancer too small to feel.

- A) four years
- B) five years
- C) three years
- D) two years
- E) year

- 31) Which one of the following is NOT an option for prostate problems: 31) \_\_\_\_\_
- A) incineration of excess prostate tissue by radiation
  - B) microwaves to shrink the prostate
  - C) drugs such as finasteride
  - D) coitus interruptus
  - E) surgery
- 32) The stage of labor that involves the delivery of the infant is the: 32) \_\_\_\_\_
- A) secretory phase
  - B) postpartum stage
  - C) expulsion stage
  - D) placental stage
  - E) dilation stage
- 33) The process in which sperm are streamlined into a head, midpiece, and tail is called: 33) \_\_\_\_\_
- A) oogenesis
  - B) ovulation
  - C) acrosomal reaction
  - D) spermiogenesis
  - E) spermatogenesis
- 34) Which one of the following is NOT one of the secondary sex characteristics in young women: 34) \_\_\_\_\_
- A) widening and lightening of the pelvis
  - B) appearance of axillary and pubic hair
  - C) enlargement of the accessory organs of reproduction
  - D) decreased fat deposits beneath the skin
  - E) breast development
- 35) Which one of the following is NOT one of the secondary sex characteristics typical of males: 35) \_\_\_\_\_
- A) thickening of bones
  - B) increased growth of body hair
  - C) deepening voice
  - D) enlargement of skeletal muscle mass
  - E) increased sex drive
- 36) The middle part of the male urethra that extends from the prostate to the penis is called the: 36) \_\_\_\_\_
- A) spongy urethra
  - B) prostatic urethra
  - C) membranous urethra
  - D) bulbourethra
  - E) penile urethra
- 37) Each spermatid and ovum have: 37) \_\_\_\_\_
- A) 46 pairs of chromosomes
  - B) 23 pairs of chromosomes
  - C) 46 chromosomes

D) 23 chromosomes

E) 2n chromosomes

- 38) Spermatogenesis begins: 38) \_\_\_\_\_  
A) during puberty  
B) during old age  
C) at birth  
D) during adulthood  
E) prior to birth
- 39) The fibrous connective tissue enclosing each testis is the: 39) \_\_\_\_\_  
A) seminiferous tubule  
B) tunica albuginea  
C) interstitial cells  
D) spermatic cord  
E) ductus deferens
- 40) Maturing sperm gain their ability to swim while in the: 40) \_\_\_\_\_  
A) epididymis  
B) seminiferous tubules  
C) ductus deferens  
D) ejaculatory duct  
E) urethra
- 41) The narrow outlet of the uterus that projects into the vagina is called the: 41) \_\_\_\_\_  
A) body  
B) fundus  
C) cervix  
D) vagina  
E) myometrium
- 42) Parturition is another term for: 42) \_\_\_\_\_  
A) menstruation  
B) menses  
C) menopause  
D) childbirth  
E) fertilization
- 43) The correct descending order of the male duct system (from inside to outside) is: 43) \_\_\_\_\_  
A) ejaculatory duct, epididymis, ductus deferens, urethra  
B) epididymis, ductus deferens, urethra, ejaculatory duct  
C) ductus deferens, epididymis, ejaculatory duct, urethra  
D) ejaculatory duct, ductus deferens, epididymis, urethra  
E) epididymis, ductus deferens, ejaculatory duct, urethra
- 44) The entire process of spermatogenesis takes approximately: 44) \_\_\_\_\_  
A) 64-72 days  
B) 120 days  
C) 25-50 days  
D) 15 years  
E) 1 year

- 45) The journey of the oocyte through the uterine tubes to the uterus following ovulation normally takes: 45) \_\_\_\_\_  
A) 24 hours      B) 10 days      C) 3-4 days      D) 1 week      E) 1 hour
- 46) Irregular uterine contractions called Braxton Hicks: 46) \_\_\_\_\_  
A) are a symptom of placenta previa  
B) signal impending labor  
C) are also known as false labor  
D) are a symptom of abruptio placenta  
E) are a symptom of toxemia
- 47) The placenta is usually functioning to deliver nutrients and oxygen to, and remove waste from, the embryonic blood by the \_\_\_\_\_ of pregnancy. 47) \_\_\_\_\_  
A) first week  
B) second week  
C) third week  
D) fourth week  
E) fifth week
- 48) The process by which a mature egg is ejected from the ovary is called: 48) \_\_\_\_\_  
A) erection  
B) menses  
C) fertilization  
D) ovulation  
E) ejaculation
- 49) The menstrual cycle is: 49) \_\_\_\_\_  
A) 28 days long  
B) 40 days long  
C) 60 days long  
D) 14 days long  
E) 7 days long
- 50) Male sex chromosomes are represented by: 50) \_\_\_\_\_  
A) YY      B) XO      C) XZ      D) XX      E) XY
- 51) Which one of the following is NOT a component of semen: 51) \_\_\_\_\_  
A) seminal fluid  
B) epididymal fluid  
C) prostatic fluid  
D) sperm  
E) bulbourethral fluid
- 52) During oogenesis, an oogonium directly gives rise to: 52) \_\_\_\_\_  
A) a primary oocyte  
B) a secondary oocyte  
C) an ovum  
D) a first polar body  
E) a second polar body
- 53) The mammary glands are: 53) \_\_\_\_\_  
A) modified lacrimal glands

- B) modified sweat glands in females only
- C) modified sebaceous glands
- D) modified sweat glands in both males and females
- E) modified ceruminous glands

- 54) Which one of the following is NOT true of the spermatic cord: 54) \_\_\_\_\_
- A) it contains nerves
  - B) it contains blood vessels
  - C) it encloses the epididymis
  - D) it is a connective tissue sheath
  - E) it encloses the ductus deferens
- 55) Days 15–28 of the menstrual cycle are known as: 55) \_\_\_\_\_
- A) implantation
  - B) menses
  - C) the secretory phase
  - D) the menstrual phase
  - E) secretory phase
- 56) The actual "sperm-forming factories" of the male reproductive system that empty sperm into the rete testes are called the: 56) \_\_\_\_\_
- A) interstitial cells
  - B) ductus deferens
  - C) epididymis
  - D) seminiferous tubules
  - E) bulbourethral glands
- 57) Which one of the following is a method of birth control available to men only: 57) \_\_\_\_\_
- A) Norplant<sup>®</sup>
  - B) diaphragm
  - C) vasectomy
  - D) condoms
  - E) IUD

**SHORT ANSWER. Write the word or phrase that best completes each statement or answers the question.**

*Fill in the blank or provide a short answer:*

- 58) The entire process of spermatogenesis takes \_\_\_\_\_ days. 58) \_\_\_\_\_
- 59) The type of sugar that is found in semen and provides essentially all the energy fuel for sperm is called \_\_\_\_\_. 59) \_\_\_\_\_
- 60) The hormone testosterone is produced by the \_\_\_\_\_ cells of the testes. 60) \_\_\_\_\_
- 61) Mammary glands are modified \_\_\_\_\_ glands. 61) \_\_\_\_\_

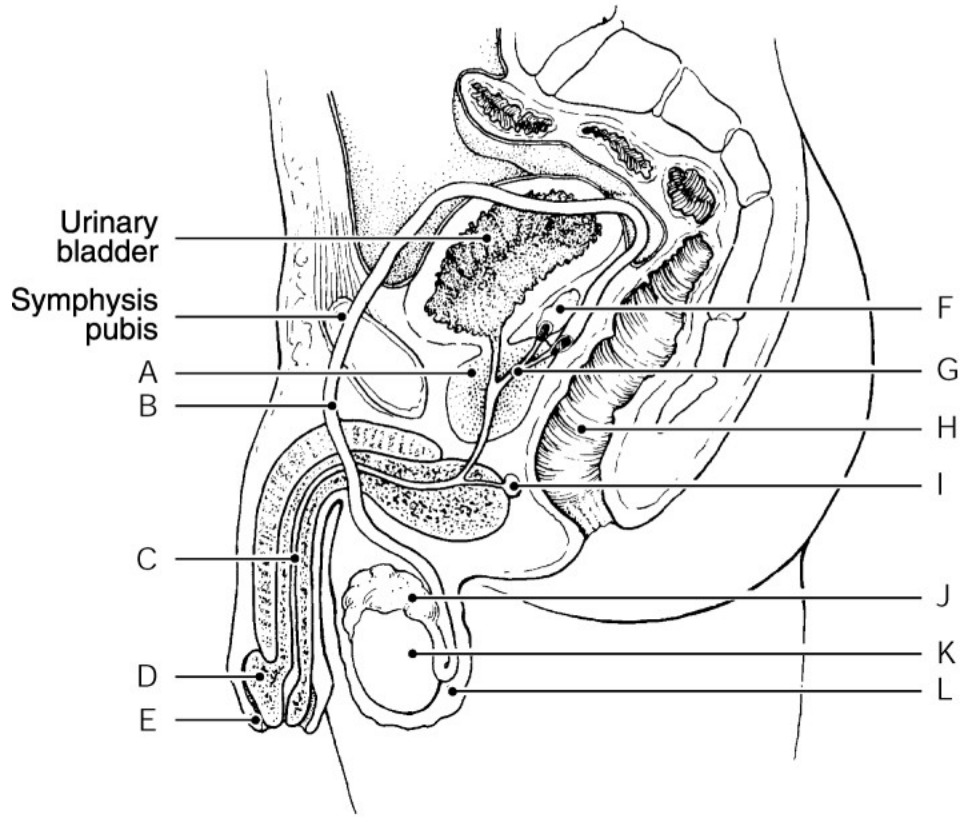

Figure 16.1

Using Figure 16.1, identify the following:

62) The prepuce is indicated by letter \_\_\_\_\_.

62) \_\_\_\_\_

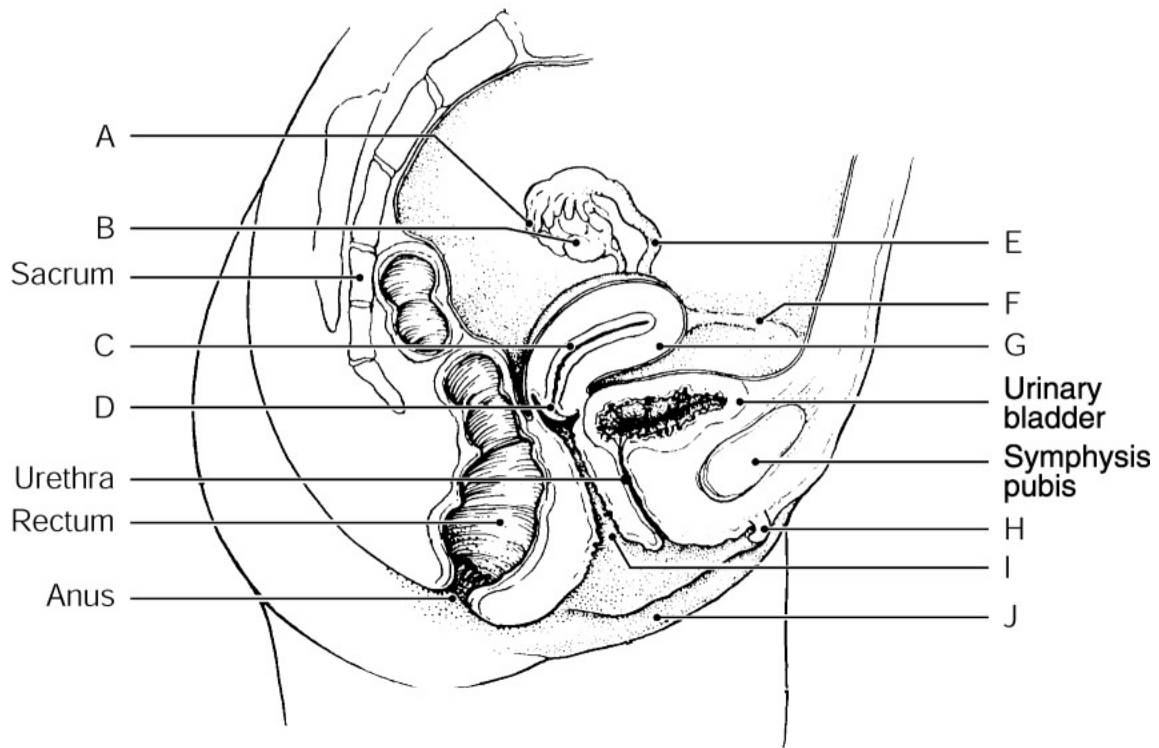

Figure 16.2

Using Figure 16.2, identify the following:



63) The uterine (fallopian) tube is indicated by letter \_\_\_\_\_.

63) \_\_\_\_\_

Fill in the blank or provide a short answer:

64) Days 1-5 of the menstrual cycle are the first phase known as the \_\_\_\_\_ phase.

64) \_\_\_\_\_

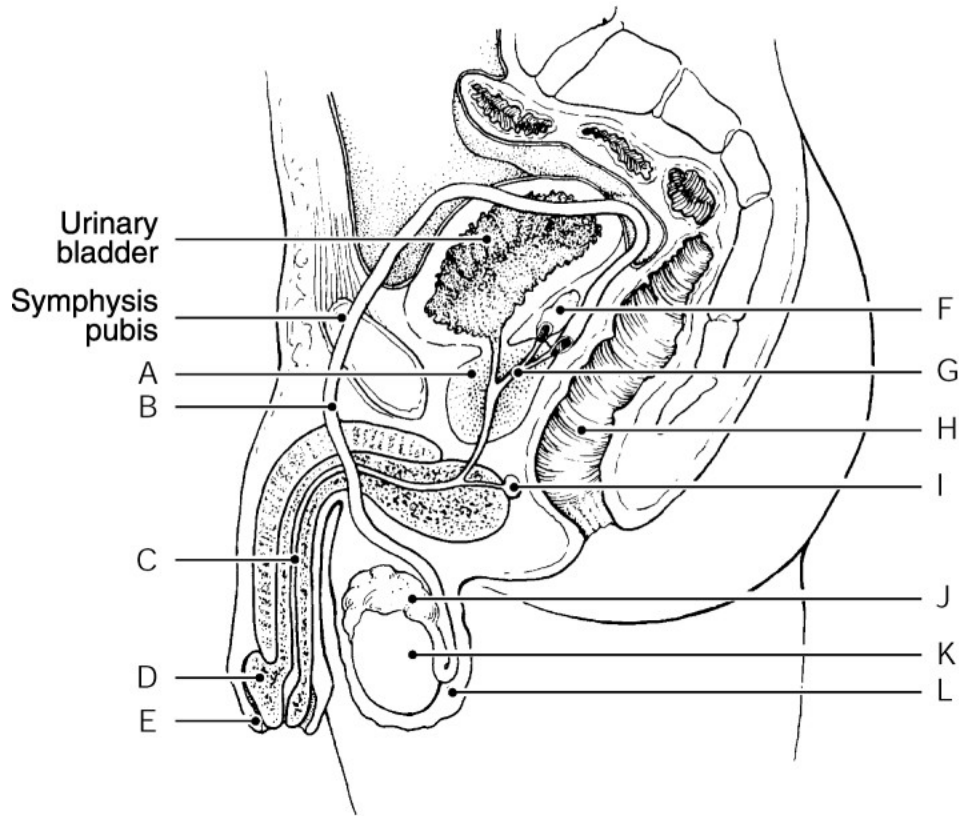

Figure 16.1

Using Figure 16.1, identify the following:

65) The seminal vesicle is indicated by letter \_\_\_\_\_.

65) \_\_\_\_\_

Fill in the blank or provide a short answer:

66) Burrowing of the fertilized egg into the endometrium lining of the uterus is called \_\_\_\_\_.

66) \_\_\_\_\_

67) The Graafian (vesicular) follicle, which is ruptured following ovulation, is called the \_\_\_\_\_.

67) \_\_\_\_\_

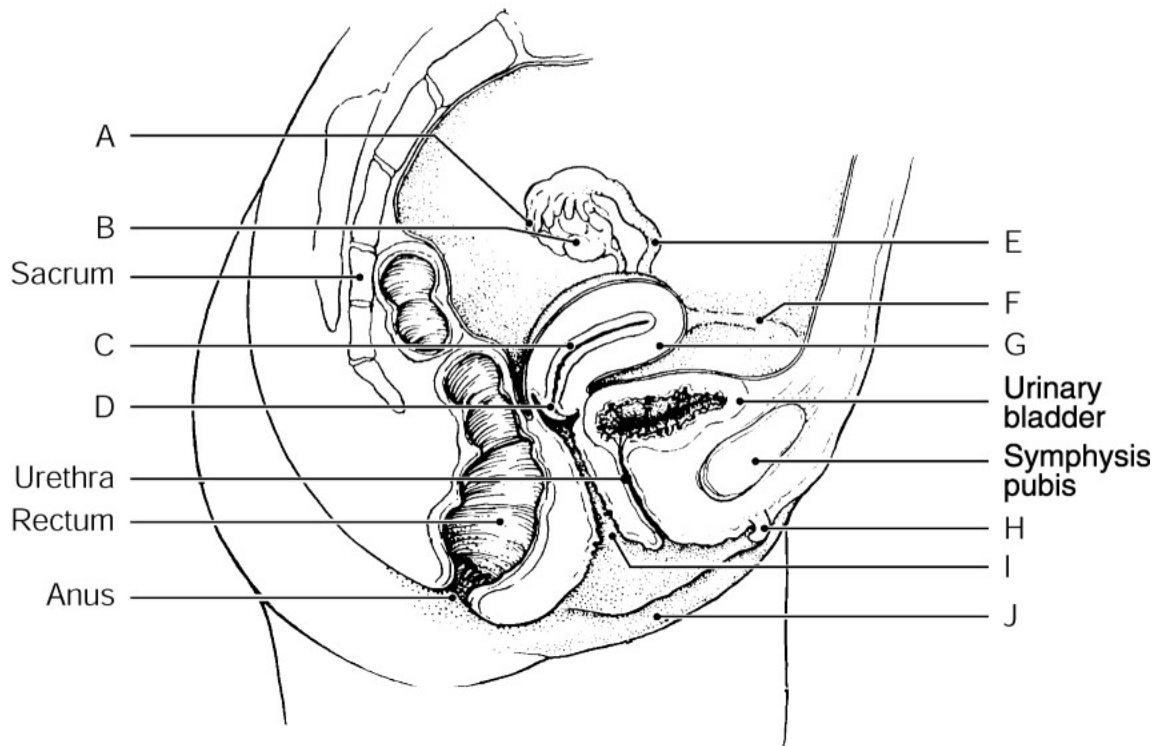

Figure 16.2

Using Figure 16.2, identify the following:

68) The round ligament is indicated by letter \_\_\_\_\_. 68) \_\_\_\_\_

Fill in the blank or provide a short answer:

69) The ovum has \_\_\_\_\_ chromosomes. 69) \_\_\_\_\_

70) The hormone that causes pelvic ligaments and the pubic symphysis to relax, widen, and become more flexible is called \_\_\_\_\_. 70) \_\_\_\_\_

71) Tiny saclike structures within the ovaries in which oocytes are found are called \_\_\_\_\_. 71) \_\_\_\_\_

72) The enlarged tip of the penis is called the \_\_\_\_\_. 72) \_\_\_\_\_

73) The helmet-like region of the sperm that is similar to a large lysosome and assists penetration of the egg is called the \_\_\_\_\_. 73) \_\_\_\_\_

74) The hormone that promotes a small number of primary follicles within the ovary to grow and mature each month is \_\_\_\_\_. 74) \_\_\_\_\_

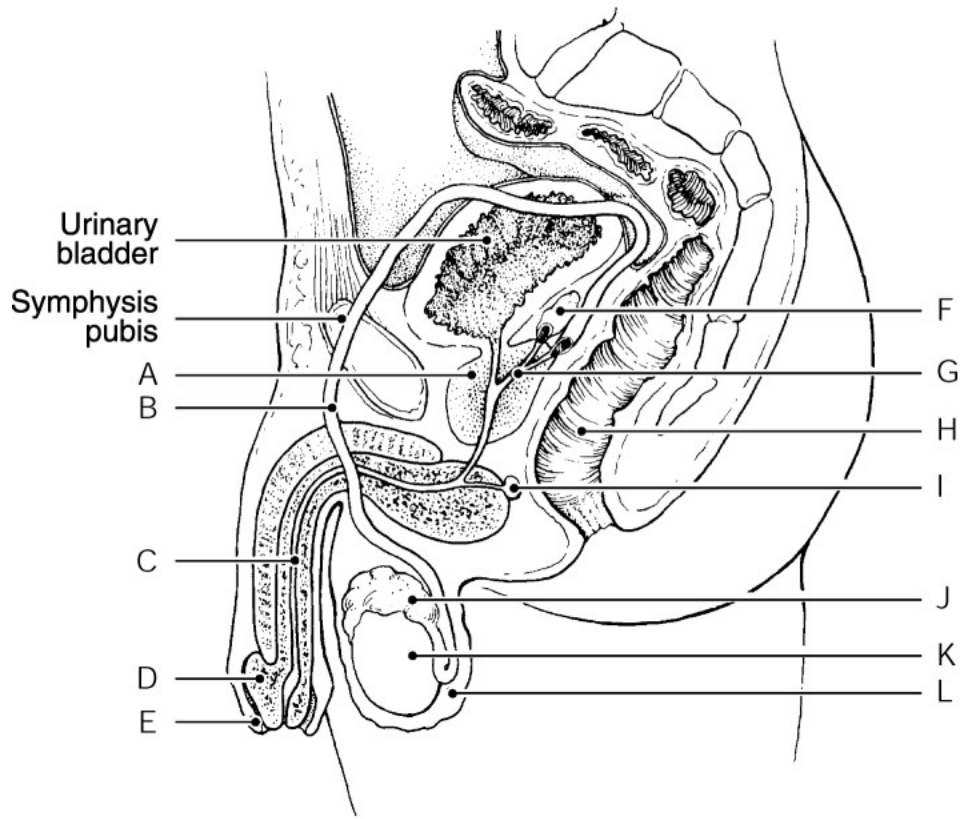

Figure 16.1

Using Figure 16.1, identify the following:

75) The ductus (vas) deferens is indicated by letter \_\_\_\_\_.

75) \_\_\_\_\_

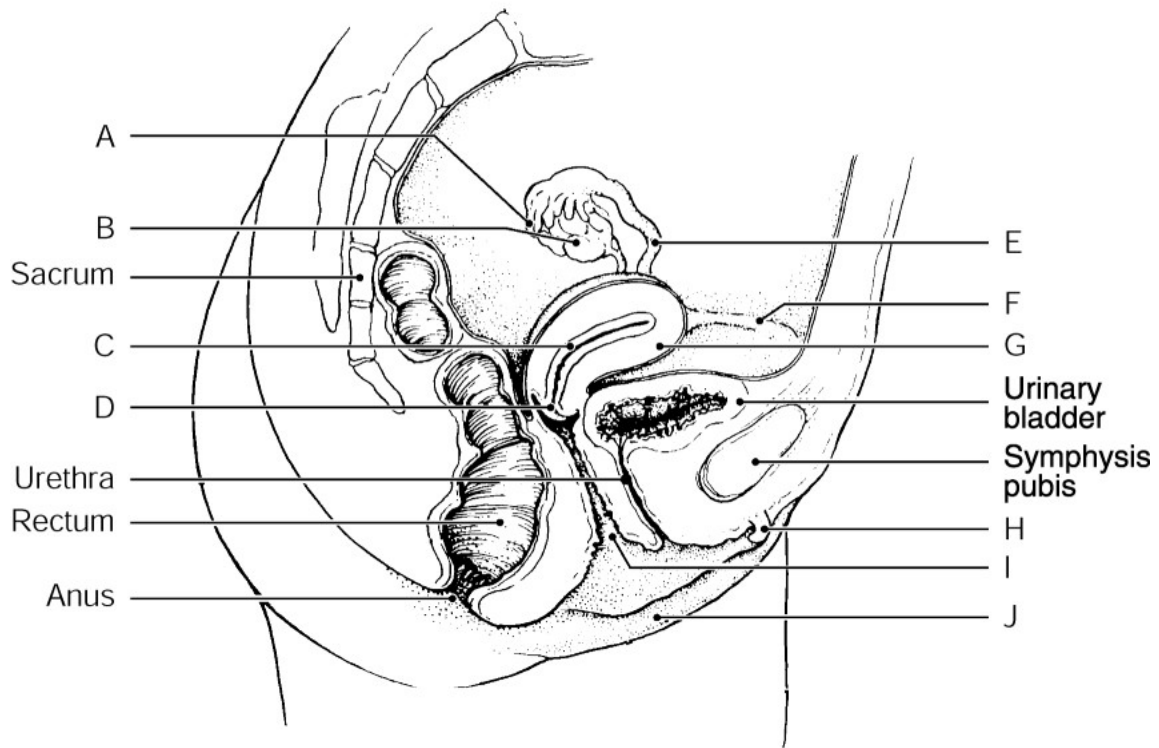

Figure 16.2

Using Figure 16.2, identify the following:

76) The clitoris is indicated by letter \_\_\_\_\_.

76) \_\_\_\_\_

*Fill in the blank or provide a short answer:*

77) The early stage of embryonic development during which rapid mitotic cell divisions occur as the zygote travels down the uterine tube is called \_\_\_\_\_.

77) \_\_\_\_\_

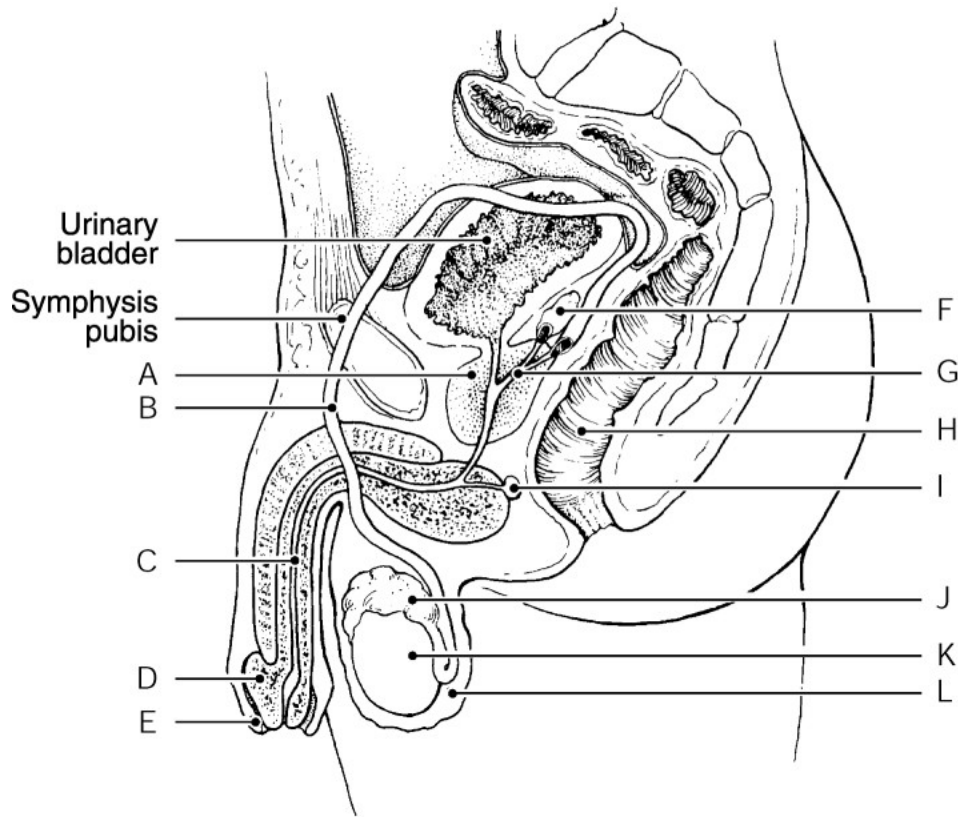

Figure 16.1

*Using Figure 16.1, identify the following:*

78) The testis is indicated by letter \_\_\_\_\_.

78) \_\_\_\_\_

*Fill in the blank or provide a short answer:*

79) The follicle-cell capsule surrounding an ovulated secondary oocyte is called the \_\_\_\_\_.

79) \_\_\_\_\_

80) The cessation of ovulation and menses for an entire year is called \_\_\_\_\_.

80) \_\_\_\_\_

81) The ligament that anchors the anterior portion of the uterus is called the \_\_\_\_\_.

81) \_\_\_\_\_

82) A fertilized egg, which represents the first cell of a new individual, is called a \_\_\_\_\_.

82) \_\_\_\_\_

83) The first stage of labor is known as the \_\_\_\_\_ stage.

83) \_\_\_\_\_

84) Another term for the foreskin that is surgically removed during circumcision is the \_\_\_\_\_.

84) \_\_\_\_\_

85) The process of creating female gametes is called \_\_\_\_\_.

85) \_\_\_\_\_

86) The fibrous "white coat" connective tissue capsule surrounding each testis is called the \_\_\_\_\_.

86) \_\_\_\_\_

87) The male sterilization birth control procedure that involves cauterization of the ductus deferens is called \_\_\_\_\_.

87) \_\_\_\_\_

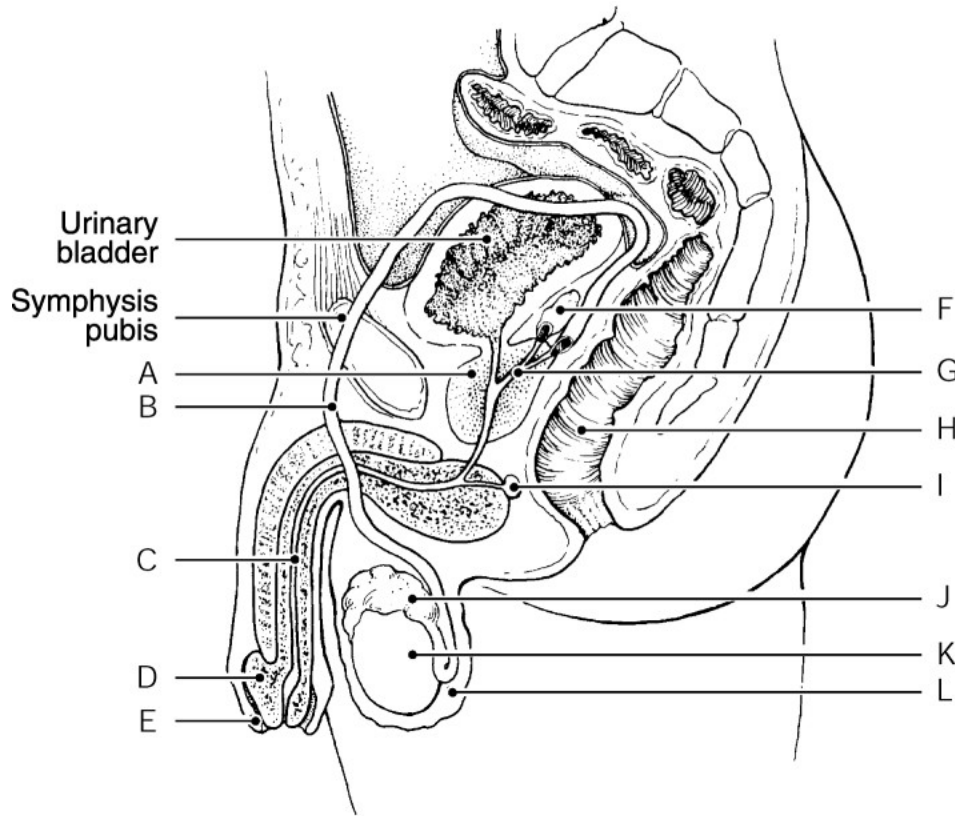

Figure 16.1

Using Figure 16.1, identify the following:

88) The urethra is indicated by letter \_\_\_\_\_.

88) \_\_\_\_\_

Fill in the blank or provide a short answer:

89) A mature ovarian follicle that is ready to be ejected from an ovary is called a \_\_\_\_\_.

89) \_\_\_\_\_

90) The innermost layer of the uterus is a mucosa layer called the \_\_\_\_\_.

90) \_\_\_\_\_

91) The finger-like projections that partially surround the ovary at the distal end of each uterine tube is called \_\_\_\_\_.

91) \_\_\_\_\_

92) The labia majora enclose the region known as the \_\_\_\_\_, which contains the external opening of the urethra.

92) \_\_\_\_\_

93) The hormone produced by the corpus luteum that helps maintain pregnancy is called \_\_\_\_\_.

93) \_\_\_\_\_

94) The glands that produce a thick, yellowish secretion which nourishes and activates sperm are the \_\_\_\_\_.

94) \_\_\_\_\_

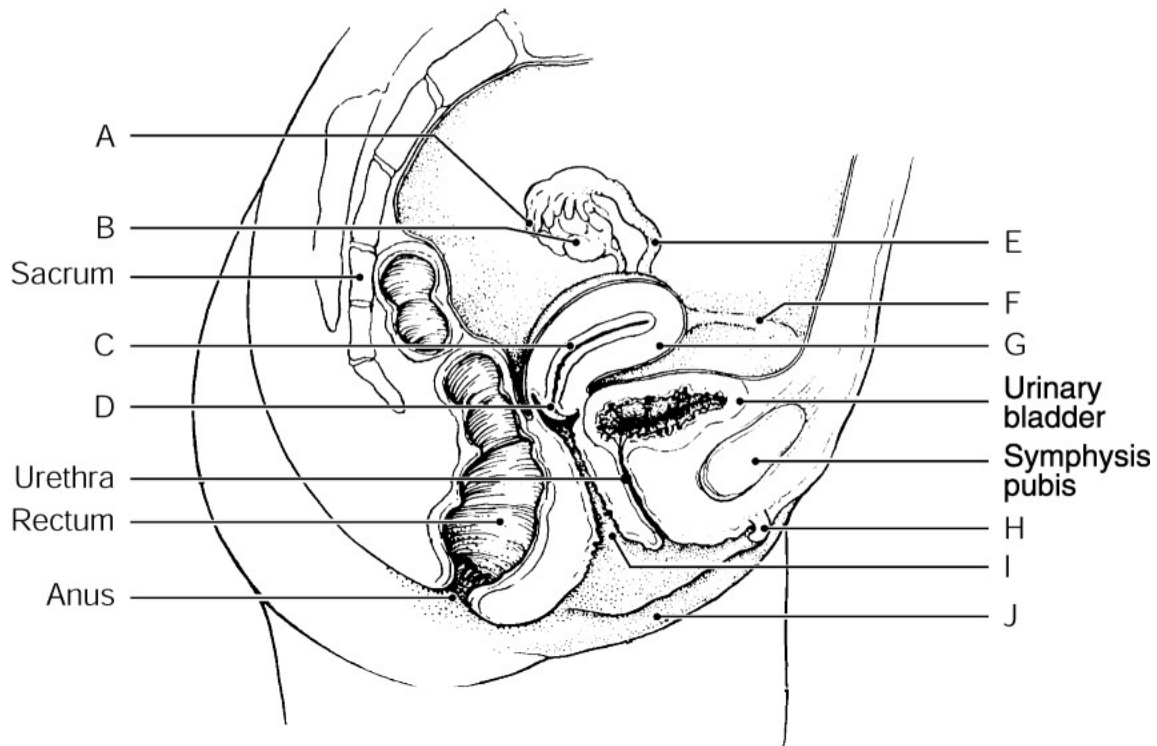

Figure 16.2

Using Figure 16.2, identify the following:

95) The ovary is indicated by letter \_\_\_\_\_.

95) \_\_\_\_\_

Fill in the blank or provide a short answer:

96) The primary germ layer that gives rise to the nervous system and epidermis of the skin is called the \_\_\_\_\_.

96) \_\_\_\_\_

97) The series of events that expel the infant from the uterus are referred to collectively as \_\_\_\_\_.

97) \_\_\_\_\_

98) Individuals who possess both ovarian and testicular tissues are called \_\_\_\_\_.

98) \_\_\_\_\_

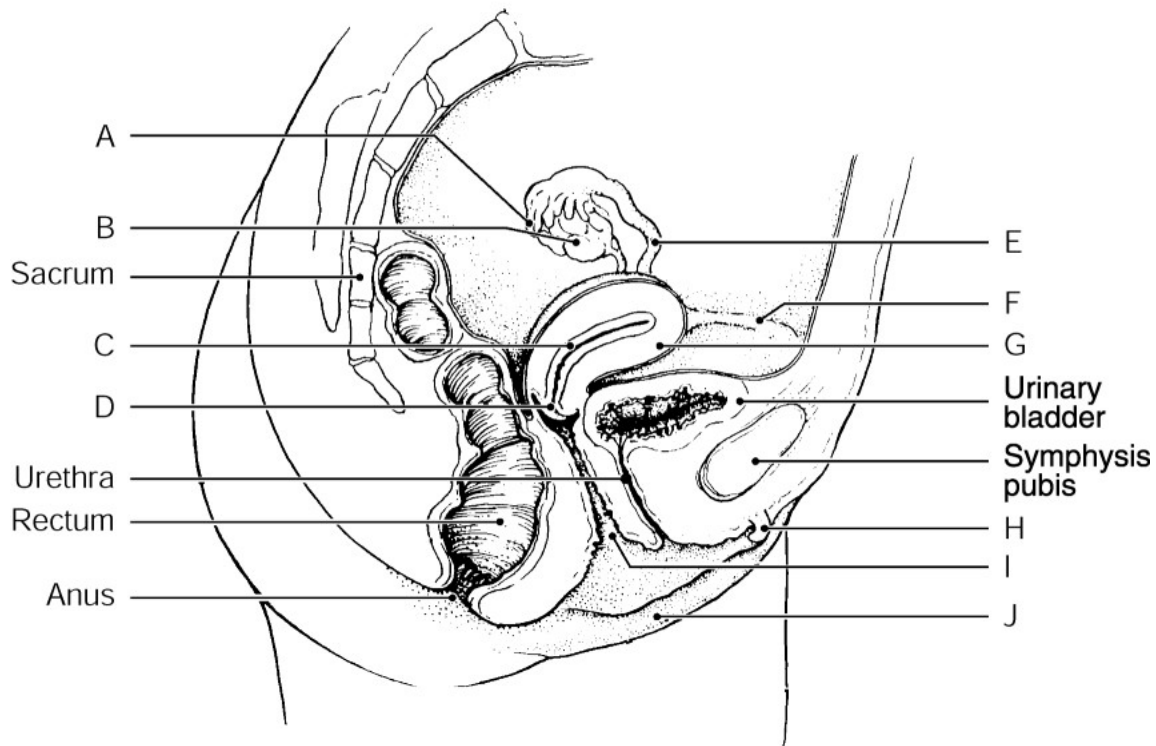

Figure 16.2

Using Figure 16.2, identify the following:

99) The fimbriae are indicated by letter \_\_\_\_\_. 99) \_\_\_\_\_

Fill in the blank or provide a short answer:

100) The bacteria from gonorrhea and other infections can spread to the peritoneal cavity. Unless treated promptly, the infection condition can cause \_\_\_\_\_, which is a major cause of female infertility. 100) \_\_\_\_\_

101) The thin fold of mucosa that partially closes the distal end of the vagina before the first experience of sexual intercourse is called the \_\_\_\_\_. 101) \_\_\_\_\_

102) The placenta and its attached fetal membranes, expelled from the uterus during the placental stage of labor, are collectively referred to as the \_\_\_\_\_. 102) \_\_\_\_\_

103) The process by which the acrosome membranes of sperm break down is known as the \_\_\_\_\_. 103) \_\_\_\_\_

**TRUE/FALSE. Write 'T' if the statement is true and 'F' if the statement is false.**

104) False labor is caused by Braxton Hicks contractions. 104) \_\_\_\_\_

105) The acrosome helps a sperm penetrate the follicle cells that surround the egg. 105) \_\_\_\_\_

106) The rapid mitotic cell division that occurs after the fertilization of an egg is known as cleavage. 106) \_\_\_\_\_

107) After ovulation, the egg is transformed into a corpus luteum. 107) \_\_\_\_\_

108) The cervix typically dilates to about 10 cm during the dilation stage of labor. 108) \_\_\_\_\_

109) Spermatids have 46 chromosomes. 109) \_\_\_\_\_

- 110) Menopause generally occurs between ages 10 and 15 in females. 110) \_\_\_\_
- 111) The placenta and its attached fetal membranes, delivered during the placental stage of labor, are called the afterbirth. 111) \_\_\_\_
- 112) Penetration of the secondary oocyte by a sperm stimulates its nucleus to undergo the second meiotic division. 112) \_\_\_\_
- 113) The cyclic changes that occur monthly in the ovary constitute the ovarian cycle. 113) \_\_\_\_
- 114) When a woman is not pregnant, the endometrial lining of the uterus is sloughed off about every 28 days. 114) \_\_\_\_
- 115) Breast cancer is a leading cause of death in American women, with self-examination and mammography being the best forms of early detection. 115) \_\_\_\_
- 116) The portion of the male urethra that is surrounded by the prostate is called the membranous urethra. 116) \_\_\_\_
- 117) Viable sperm cannot be produced at below body temperature. 117) \_\_\_\_
- 118) Oocytes are carried toward the uterus by both cilia and peristalsis. 118) \_\_\_\_
- 119) The smooth muscle walls of the ductus deferens (also called vas deferens) create peristaltic waves that rapidly squeeze the sperm forward. 119) \_\_\_\_
- 120) Detection of uterine cancer is best accomplished by a yearly Pap smear. 120) \_\_\_\_
- 121) The diamond-shaped region of a female's external genitalia found between the anterior end of the labial folds, the anus posteriorly, and the ischial tuberosities is called the perineum. 121) \_\_\_\_
- 122) Sperm swim faster in an alkaline environment and are more sluggish in an acidic environment. 122) \_\_\_\_
- 123) Urine and sperm are able to pass through the urethra at the same time. 123) \_\_\_\_
- 124) Ovaries are the size and shape of almonds and contain many tiny saclike structures called ovarian follicles, each of which consists of an immature egg surrounded by one or more layers of follicle cells. 124) \_\_\_\_
- 125) Ovulation usually occurs on or about day 14 of the menstrual cycle. 125) \_\_\_\_
- 126) The two functional areas of the blastocyst are the morula and the trophoblast. 126) \_\_\_\_
- 127) One primary spermatocyte will undergo meiosis to ultimately form four sperm. 127) \_\_\_\_
- 128) The endoderm gives rise to the nervous system and the epidermis of the skin. 128) \_\_\_\_
- 129) The trip through the coiled 20-foot (6 meter) long epididymis takes about 20 days. 129) \_\_\_\_
- 130) The bulbourethral glands are located inferior to the prostate gland and produce a clear mucous secretion that aids lubrication during sexual intercourse. 130) \_\_\_\_



- 131) Ovulation occurs during the secretory phase of the menstrual cycle. 131) \_\_\_\_\_
- 132) A primary oocyte undergoes meiosis and produces a secondary oocyte and a polar body. 132) \_\_\_\_\_
- 133) The rete testis connects the epididymis to the ductus deferens. 133) \_\_\_\_\_
- 134) Beginning at the ninth week of development, the embryo is referred to as a fetus. 134) \_\_\_\_\_
- 135) The hormone that causes secondary sex characteristics in males is progesterone. 135) \_\_\_\_\_
- 136) The innermost layer of the uterus is called the myometrium. 136) \_\_\_\_\_
- 137) Prostatic cancer is the common reason men consult a urologist because it is the leading type of cancer in adult men. 137) \_\_\_\_\_
- 138) The external genitalia of a female is also called the vulva. 138) \_\_\_\_\_
- 139) An erection results from blood filling the spongy erectile tissues of the penis. 139) \_\_\_\_\_
- 140) Estrogens cause the appearance of secondary sex characteristics in females. 140) \_\_\_\_\_

**MATCHING. Choose the item in column 2 that best matches each item in column 1.**

*Match each description with the appropriate female reproductive structure:*

- |   |                 |            |
|---|-----------------|------------|
| 141) Organ that is the typical site of implantation of a fertilized egg | A) vagina       | 141) _____ |
|   | B) uterus       |            |
| 142) Birth canal  | C) ovary        | 142) _____ |
| 143) Organ that produces eggs   | D) labia minora | 143) _____ |

*Match each description with the appropriate male reproductive structure:*

- |                                       |           |            |
|---------------------------------------|-----------|------------|
| 144) Organ that produces testosterone | A) testis | 144) _____ |
|                                       | B) penis  |            |

*Match each description with the appropriate female reproductive structure:*

- |   |             |            |
|---|-------------|------------|
| 145) Structure that corresponds to the male penis | A) clitoris | 145) _____ |
|---|-------------|------------|

*Identify the time period at which fetal development changes or accomplishments occur:*

- |  |                |            |
|--|----------------|------------|
| 146) Quickening (mother feels spontaneous muscular activity of fetus) occurs | A) 8 weeks     | 146) _____ |
|  | B) 17-20 weeks |            |
| 147) Fingernails and toenails are present and skin is wrinkled and red       | C) 21-30 weeks | 147) _____ |

148) All body systems are present in at least rudimentary form 148) \_\_\_\_\_

*Match each description with the appropriate male reproductive structure:*

149) Tube that transports either urine or sperm to the exterior of the body A) prostate 149) \_\_\_\_\_

B) urethra

*Identify the time period at which fetal development changes or accomplishments occur:*

150) Fetal position is assumed because of space restrictions A) 17–20 weeks 150) \_\_\_\_\_

B) 21–30 weeks

151) General sensory organs are present and blinking motion of eyes occur 151) \_\_\_\_\_

C) 4 weeks

152) Heart is actively pumping blood D) 13–16 weeks 152) \_\_\_\_\_

153) Eyes are open and myelination of spinal cord begins 153) \_\_\_\_\_

*Match each description with the appropriate female reproductive structure:*

154) Duct that transports a fertilized egg A) uterine (fallopian) tube 154) \_\_\_\_\_

*Identify the time period at which fetal development changes or accomplishments occur:*

155) Limbs are present even though they might still be webbed A) 8 weeks 155) \_\_\_\_\_

*Match each description with the appropriate male reproductive structure:*

156) Duct connecting epididymis to ejaculatory duct A) ductus (vas) deferens 156) \_\_\_\_\_

B) ejaculatory duct

*Identify the time period at which fetal development changes or accomplishments occur:*

157) Sex is readily detected from the genitals A) 17–20 weeks 157) \_\_\_\_\_

B) 21–30 weeks

158) Facial features are present in crude form 158) \_\_\_\_\_

C) 16 weeks

159) Head is nearly as large as body and major brain regions are present D) 12 weeks 159) \_\_\_\_\_

E)

160) Vernix caseosa covers body and lanugo covers skin 9–12 weeks 160) \_\_\_\_\_

*Match each description with the appropriate male reproductive structure:*

- 161) Gland that produces a thick, yellowish secretion                      A) seminal vesicles                      161) \_\_\_\_\_

*Match each description with the appropriate female reproductive structure:*

- 162) Fatty, rounded area overlying the pubic symphysis                      A) mons pubis                      162) \_\_\_\_\_

*Match each description with the appropriate male reproductive structure:*

- 163) Sac of skin found hanging outside the abdominal cavity                      A) scrotum                      163) \_\_\_\_\_

**ESSAY. Write your answer in the space provided or on a separate sheet of paper.**

- 164) Describe the process of spermatogenesis.
- 165) Describe the events of embryonic development from conception until the fetal stage, including development of the primary germ layers.
- 166) List and describe the three stages of labor.
- 167) Explain the male duct system by naming each organ and describing the role of each organ involved.
- 168) List the three male accessory glands and describe their contributions to the formation of semen.
- 169) List and describe the three major stages of the menstrual cycle.

- 1) C
- 2) B
- 3) C
- 4) D
- 5) D
- 6) C
- 7) D
- 8) B
- 9) A
- 10) C
- 11) A
- 12) E
- 13) C
- 14) B
- 15) D
- 16) E
- 17) C
- 18) A
- 19) D
- 20) D
- 21) A
- 22) D
- 23) B
- 24) B
- 25) E
- 26) A
- 27) B
- 28) D
- 29) C
- 30) D
- 31) D
- 32) C
- 33) D
- 34) D
- 35) E
- 36) C
- 37) D
- 38) A
- 39) B
- 40) A
- 41) C
- 42) D
- 43) E
- 44) A
- 45) C
- 46) C
- 47) C
- 48) D
- 49) A
- 50) E
- 51) B

- 52) A
- 53) D
- 54) C
- 55) C
- 56) D
- 57) C
- 58) 64 to 72
- 59) fructose
- 60) interstitial
- 61) sweat
- 62) E
- 63) E
- 64) menstrual
- 65) F
- 66) implantation
- 67) corpus luteum
- 68) F
- 69) 23
- 70) relaxin
- 71) ovarian follicles
- 72) glans penis
- 73) acrosome
- 74) follicle-stimulating hormone (FSH)
- 75) B
- 76) H
- 77) cleavage
- 78) K
- 79) corona radiata
- 80) menopause
- 81) round ligament
- 82) zygote
- 83) dilation
- 84) prepuce
- 85) oogenesis
- 86) tunica albuginea
- 87) vasectomy
- 88) C
- 89) Graafian (or vesicular) follicle
- 90) endometrium
- 91) fimbriae
- 92) vestibule
- 93) progesterone
- 94) seminal vesicles
- 95) B
- 96) ectoderm
- 97) labor
- 98) hermaphrodites
- 99) A
- 100) pelvic inflammatory disease
- 101) hymen
- 102) afterbirth
- 103) acrosomal reaction

104) TRUE  
105) TRUE  
106) TRUE  
107) FALSE  
108) TRUE  
109) FALSE  
110) FALSE  
111) TRUE  
112) TRUE  
113) TRUE  
114) TRUE  
115) TRUE  
116) FALSE  
117) FALSE  
118) TRUE  
119) TRUE  
120) FALSE  
121) TRUE  
122) TRUE  
123) FALSE  
124) TRUE  
125) TRUE  
126) FALSE  
127) TRUE  
128) FALSE  
129) TRUE  
130) TRUE  
131) FALSE  
132) TRUE  
133) FALSE  
134) TRUE  
135) FALSE  
136) FALSE  
137) FALSE  
138) TRUE  
139) TRUE  
140) TRUE  
141) B  
142) A  
143) C  
144) A  
145) A  
146) B  
147) C  
148) A  
149) B  
150) A  
151) C  
152) B  
153) A  
154) A  
155) A

- 156) A
- 157) D
- 158) E
- 159) B
- 160) A
- 161) A
- 162) A
- 163) A

- 164) Spermatogenesis is sperm production that begins during puberty and continues throughout life. The process is begun by primitive stem cells called spermatogonia. From birth until puberty, spermatogonia undergo mitotic division to increase the number of stem cells. During puberty, FSH causes each division of spermatogonium into one stem cell (type A cell) and one type B cell that becomes a primary spermatocyte. The primary spermatocytes then undergo meiosis to secondary spermatocytes, which then form four spermatids. The spermatids streamline and a tail is formed during spermiogenesis, after which they are mature enough to fertilize an ovum and are called sperm.
- 165) A fertilized egg (zygote) undergoes rapid mitotic cell division in a stage called cleavage. Cleavage provides the building blocks for constructing the embryo, which develops until it has about 100 cells and then hollows out to form a blastocyst. The blastocyst has two areas: the trophoblast and the inner cell mass. The inner cell mass forms the primary germ layers, which are the ectoderm, the endoderm, and the mesoderm. The ectoderm gives rise to the nervous system, the epidermis, and the skin. The endoderm forms the mucosae and associated glands. The mesoderm gives rise to everything else. The trophoblast develops projections called chorionic villi which form the placenta along with tissues from the mother's uterus. By the eighth week, all the organ systems have been laid down and the embryo looks distinctly human. Beginning in the ninth week, the embryo is referred to as a fetus.
- 166) Stage 1 is the dilation stage, which extends from the appearance of true contractions until full dilation of the cervix (dilation to about 10 cm in diameter). Usually the amnion ruptures during this stage, which is the longest part of labor and lasts for 6 to 12 hours. Stage 2 is the expulsion stage. It extends from full dilation to delivery of the infant. In this stage, the infant passes through the cervix and vagina to the outside of the body. This stage takes 20 minutes to 2 hours. Stage 3 is the placental stage, which usually lasts about 15 minutes, culminating in delivery of the placenta.
- 167) The first part of the duct system is the epididymis which connects to the rete testis of the testes on one end and the ductus deferens on the other. Sperm are temporarily stored within the epididymis, where they mature and gain the ability to swim. The next part of the duct system is the ductus deferens, also known as the vas deferens. The ductus deferens propels live sperm from their storage site in the epididymis into the urethra by means of peristalsis. The end of the ductus deferens is called the ejaculatory duct. It passes through the prostate gland and connects with the urethra. The urethra carries sperm to the body exterior.
- 168) 1. The seminal vesicles produce fluid that contributes about 60% of the fluid volume of semen. The secretion is thick, yellowish, and is rich in sugar, vitamin C, prostaglandins, and other substances that nourish and activate the sperm passing through the male's reproductive tract.  
2. The prostate produces a milky secretion that also activates the sperm.  
3. The bulbourethral glands produce a thick, clear mucus that drains into the penile urethra to cleanse it of acidic urine. This secretion is the first to be released during sexual excitement and serves as a lubricant during sexual intercourse.
- 169) Menses occurs during days 1 through 5 of the menstrual cycle. During this stage, the endometrial lining detaches from the uterine wall and sloughs off. Days 6 through 14 are the proliferative stage wherein rising estrogen levels cause the endometrial lining to regenerate. It becomes thick and velvety again and is highly vascularized. Ovulation occurs on approximately the last day of this stage in response to an LH surge. The secretory stage is from days 15 through 28. During this stage, the corpus luteum produces progesterone, which increases the endometrial blood supply and causes the endometrial glands to increase in size and begin secreting nutrients into the uterine cavity. If fertilization occurs, these nutrients will help sustain the embryo until implantation. If fertilization does not occur, the hormone levels decline and the endometrium spasms, setting the stage for menses to begin again on day 28.