

Nubian Pyramids - Meroé, Sudan





Retroviruses

HIV/AIDS

Moses Masika; MBChB, MSc(TID)

Department of Medical Microbiology

Virology Section

Outline

- Distribution
- Classification
- Characteristics
- Pathogenesis
- Clinical manifestations
- Antiretroviral drugs
- Prevention strategies

HIV Map 2013

People living with HIV

35 million people, including 3.2 million children, are HIV-positive (2013 figures)

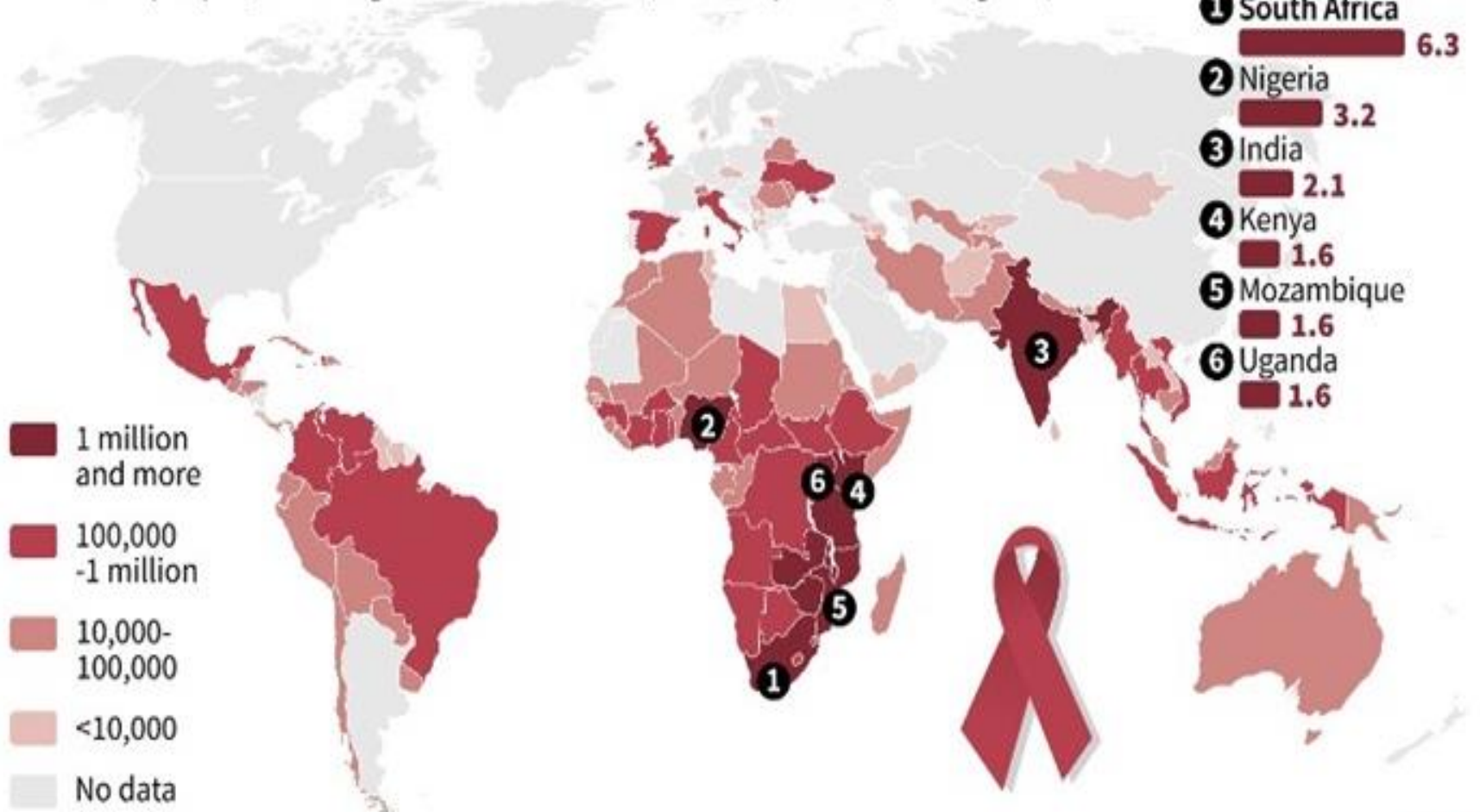

Source: Unaid

Kenya

Source: HIV Estimates Report – 2014

- Prevalence= 6%
- Burden: **1.6M** PLHIV
- **192,000** infected children
- New infections: **102,000** p.a.
- Deaths: **58,000** p.a.

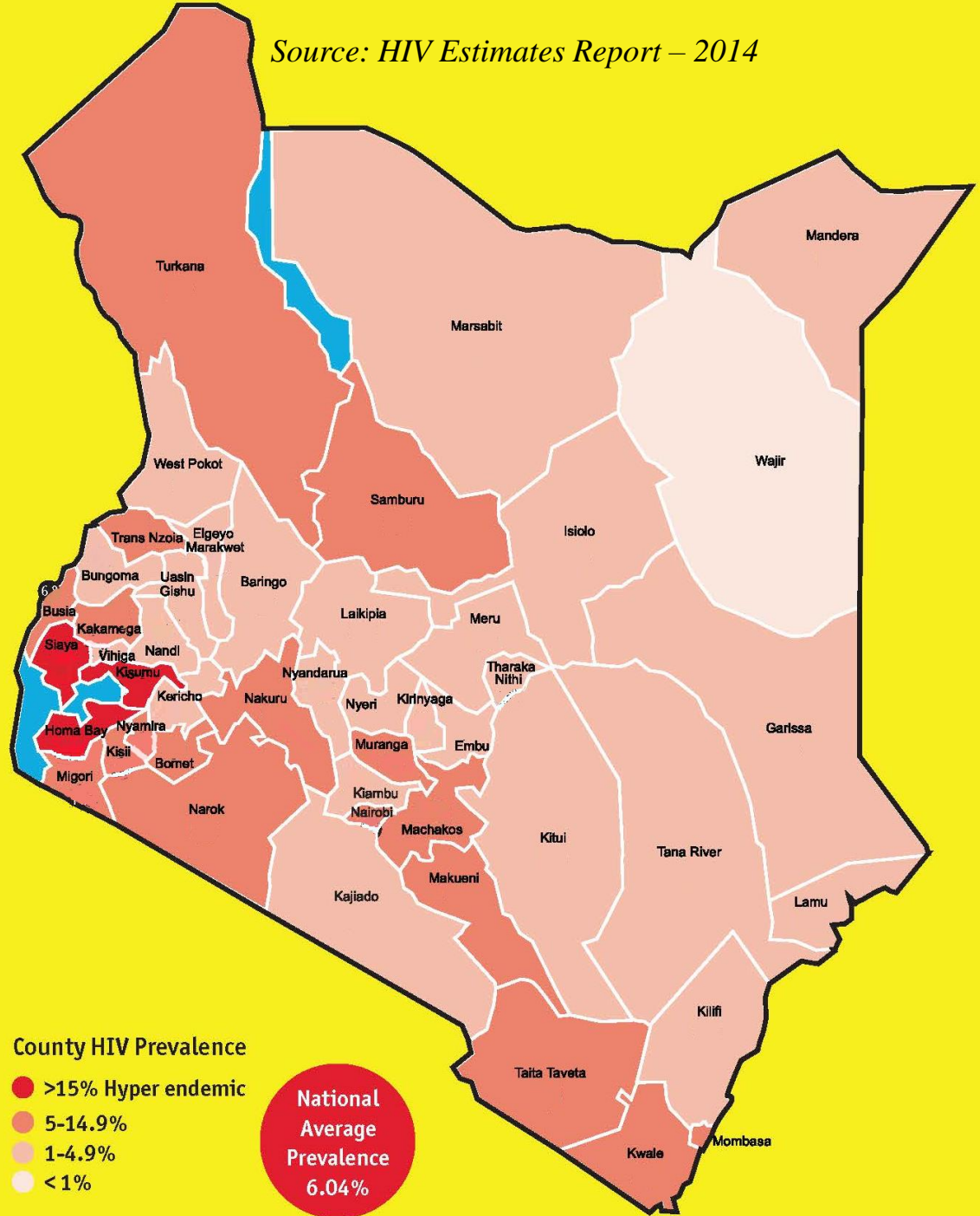

Key Populations

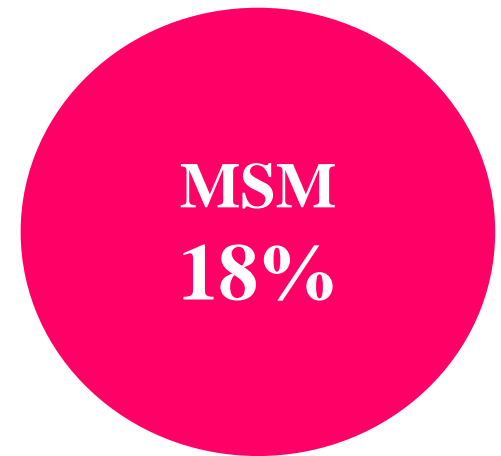
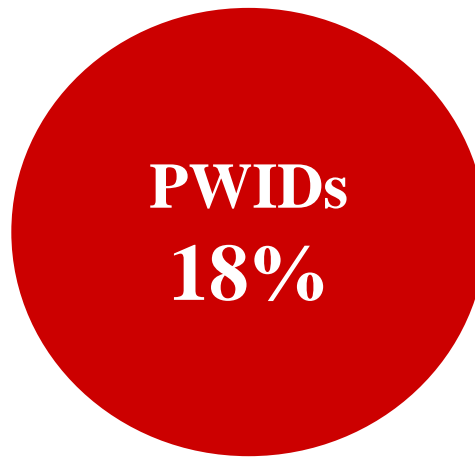

- Key populations: 2% of the population; a third of all new infections (MOTs)

Origin of HIV

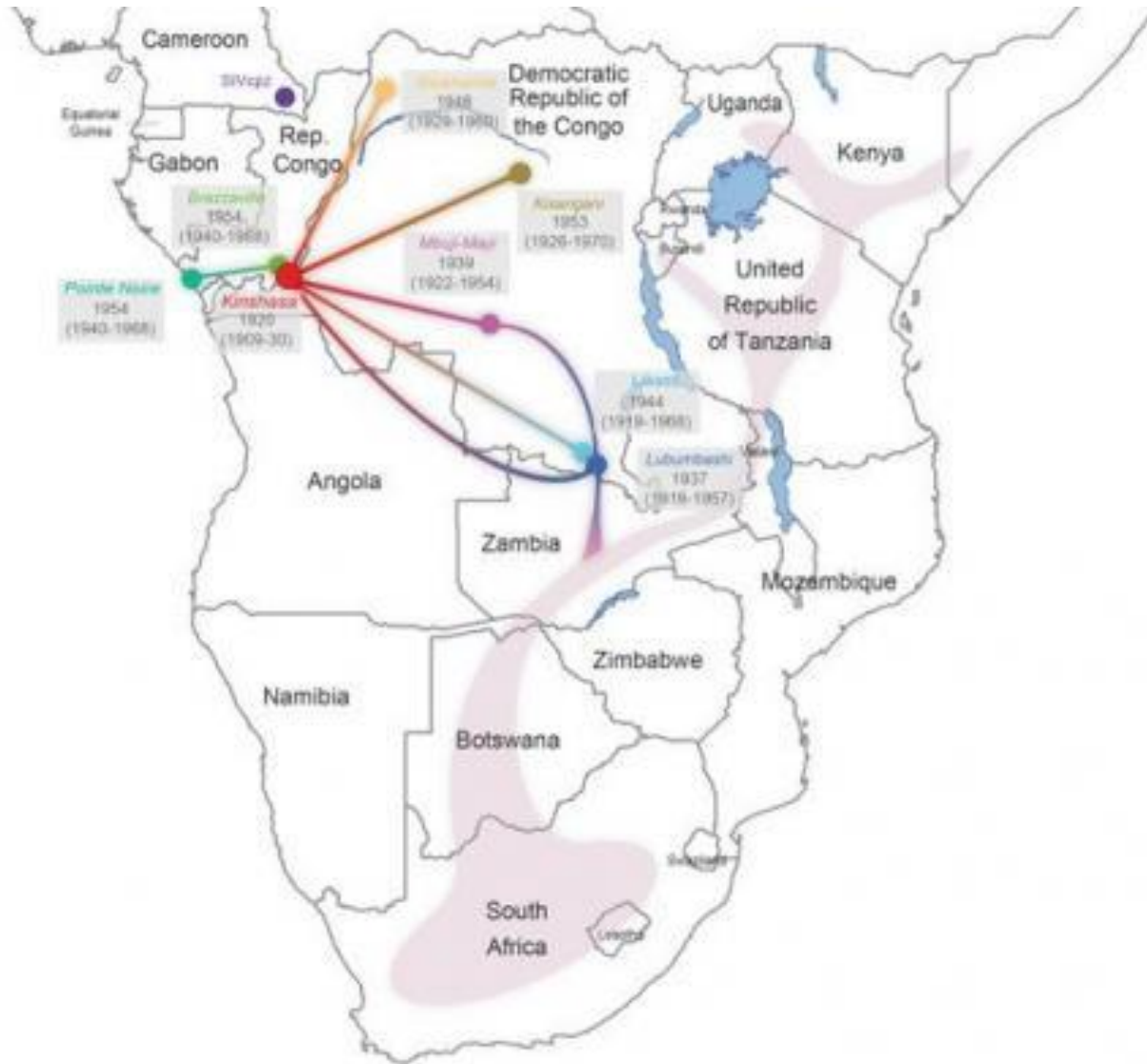

Retroviridae family

Subfamily	Genera	Species (Examples)
Orthoretrovirinae	Alpharetrovirus	e.g. Rous sarcoma virus
“	Betaretrovirus	e.g. Mouse mammary tumor virus
“	Deltaretrovirus	e.g. Human T-Lymphotropic virus(HTLV)
“	Epsilonretrovirus	Walleye dermal sarcoma virus
“	Gammaretrovirus	Viper retrovirus, Porcine type C oncovirus
“	Lentivirus	HIV-1, HIV-2, SIV, BIV, FIV, EIAIV
Spumaretrovirinae	Spumavirus	Equine foamy virus

Retroviruses

Unique features:

- Undergo reverse transcription
- Three common genes, (*gag*, *pol*, *env*) in all retroviruses
- 2 copies of ss (+)sense RNA
- The only viruses which are truly diploid
- Genome does **not** serve directly as mRNA immediately after infection like for other (+)ssRNA viruses

Lentiviruses

- Genus: *Lentivirus*
- Slow progressive infections
- Species: **HIV-1, HIV-2**
 - Others:
 - **Simian** Immunodeficiency Virus (SIV)
 - **Feline** IV
 - **Bovine** IV
 - **Equine** Infectious Anemia Virus (EIAV) etc.
 - Individual viruses are restricted to a given host species

HIV

Baltimore: Group 6 (*ssRNA + Reverse Transcriptase*)

ICTV (International Committee on Taxonomy of Viruses):

- **Family:** Retroviridae
- **Genus:** Lentiviruses
- **Species:** HIV-1 & HIV-2
- **Groups:** HIV 1 – M, N, O & P
- **Clades:** HIV-1 (*A-K, CRFs*); HIV-2 (*A-H*)

HIV Subtypes (Clades)

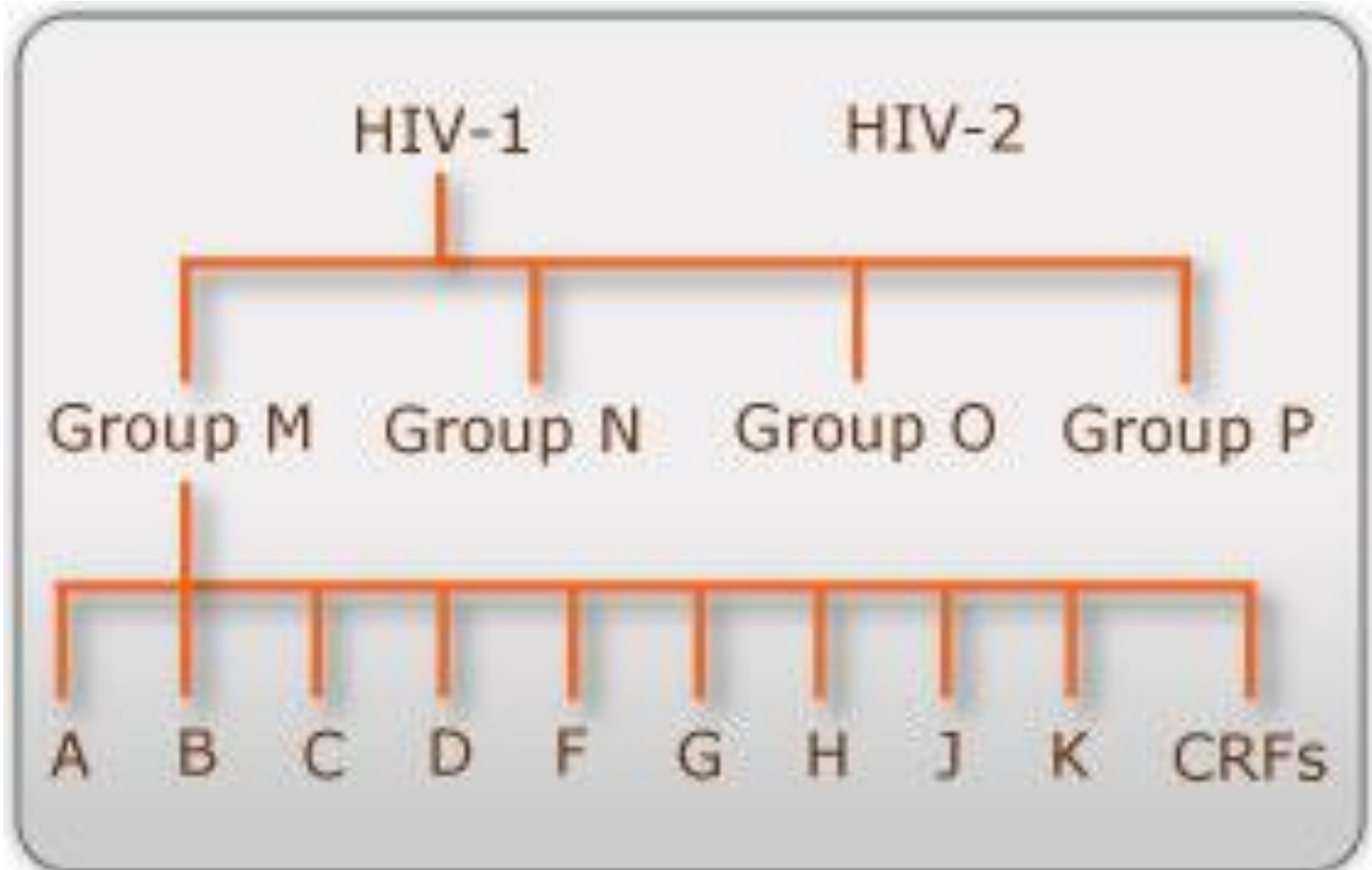

HIV-1 vs HIV-2

	HIV-1	HIV-2
Distribution	Worldwide	West Africa, Europe & USA
Transmission	Easier transmission	Less easily transmitted
Progression	Faster progression	Slower progression
Origin	Related to SIV _{cpz} (Chimpanzee SIV)	Related to SIV _{sm} (Sooty Mangabey SIV)
Treatment	Responds to NNRTIs*	No response to NNRTIs: e.g. EFV, NVP

**NNRTIs = Non-nucleoside Reverse Transcriptase Inhibitors*

Origin and Evolution of HIV

SIV_{cpz} & HIV-1



Pan troglodytes (Chimpanzee)

SIV_{sm} & HIV-2



Cercobrus atys (Sooty mangabey)

Phylogenetic tree: Relationship between HIV-1 and SIVcpz

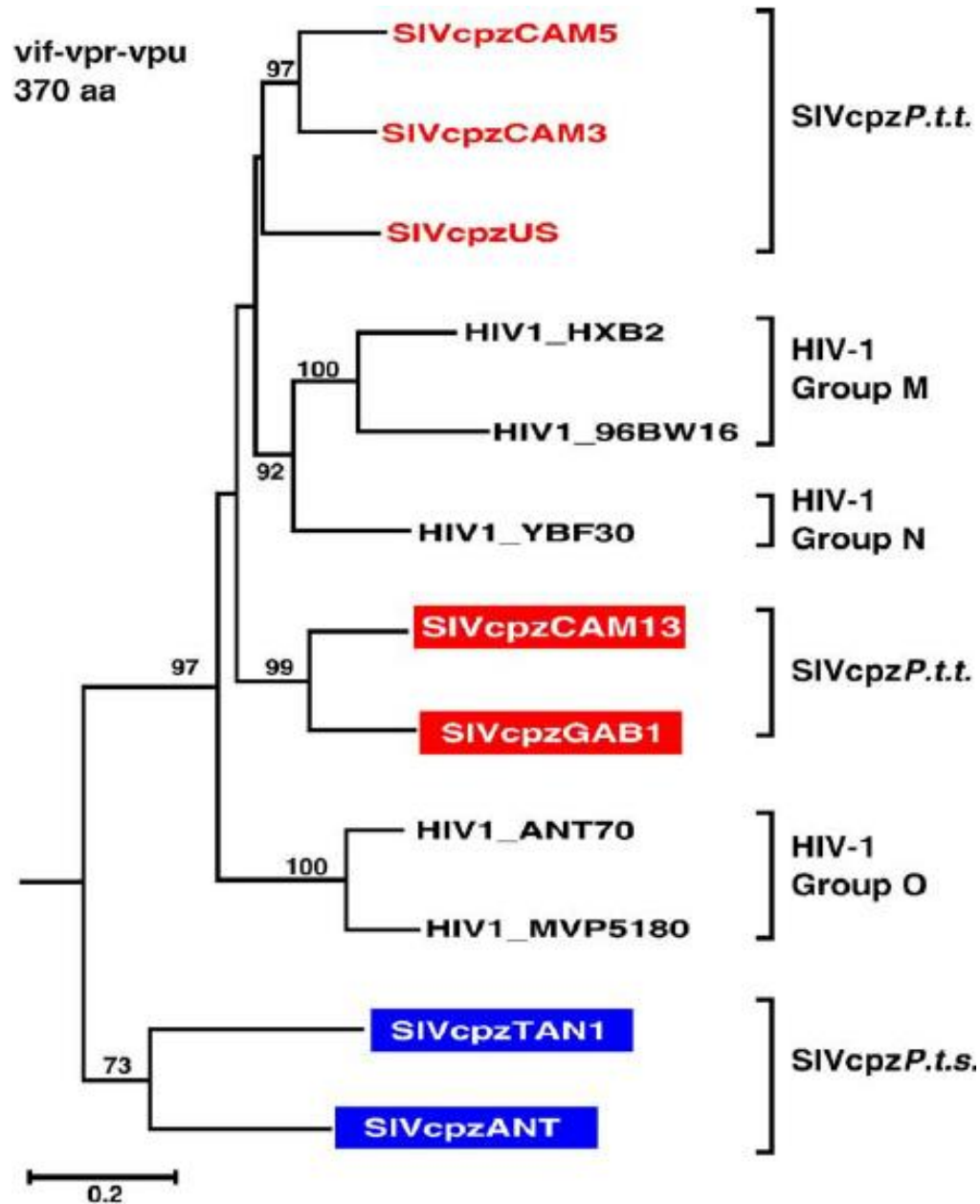

HIV-1

- AIDS 1st observed in 1981
- HIV identified in 1984
- HIV type 1 (HIV-1) & HIV type 2 (HIV-2)
- Causes AIDS: Acquired immunodeficiency syndrome:
 - Opportunistic infections: breakdown in the immune system
 - Quantitative decrease in T helper cell (CD4)

HIV 1 Genome & Structure

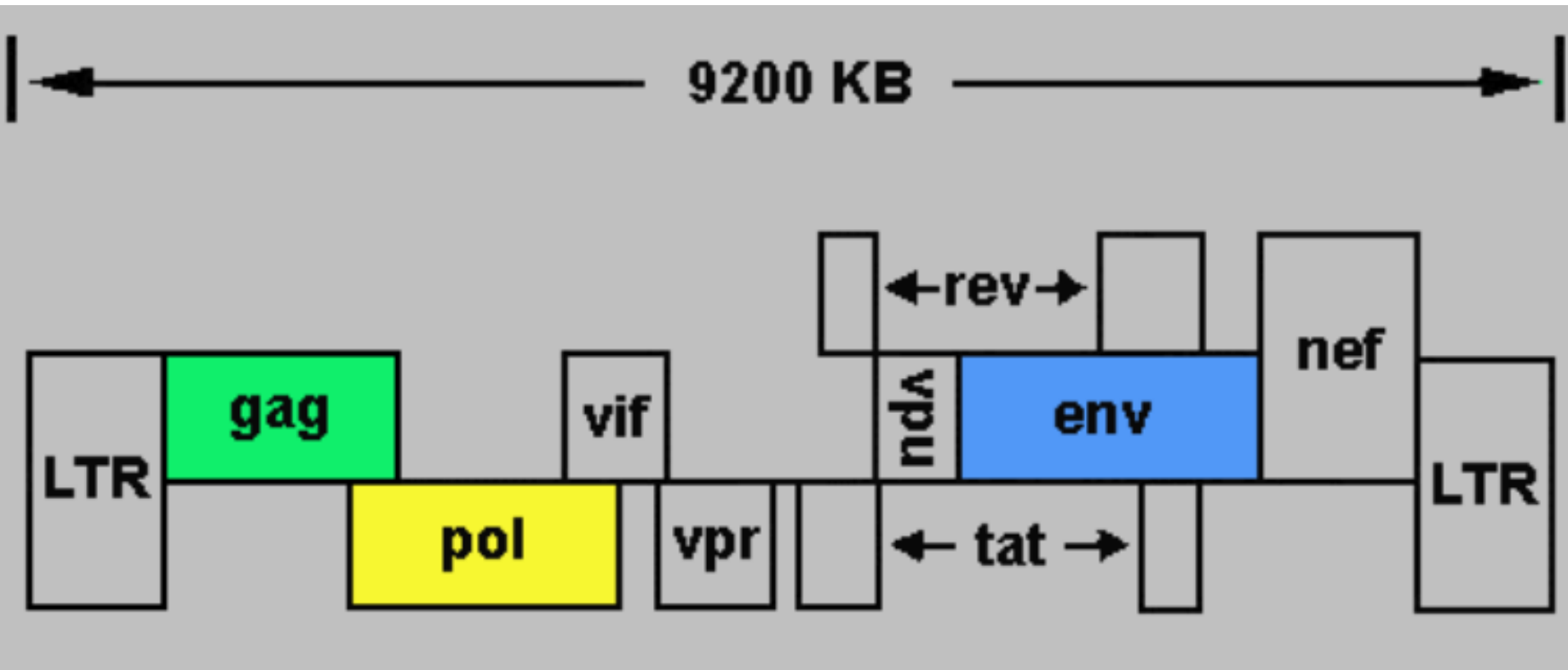

HIV Anatomy

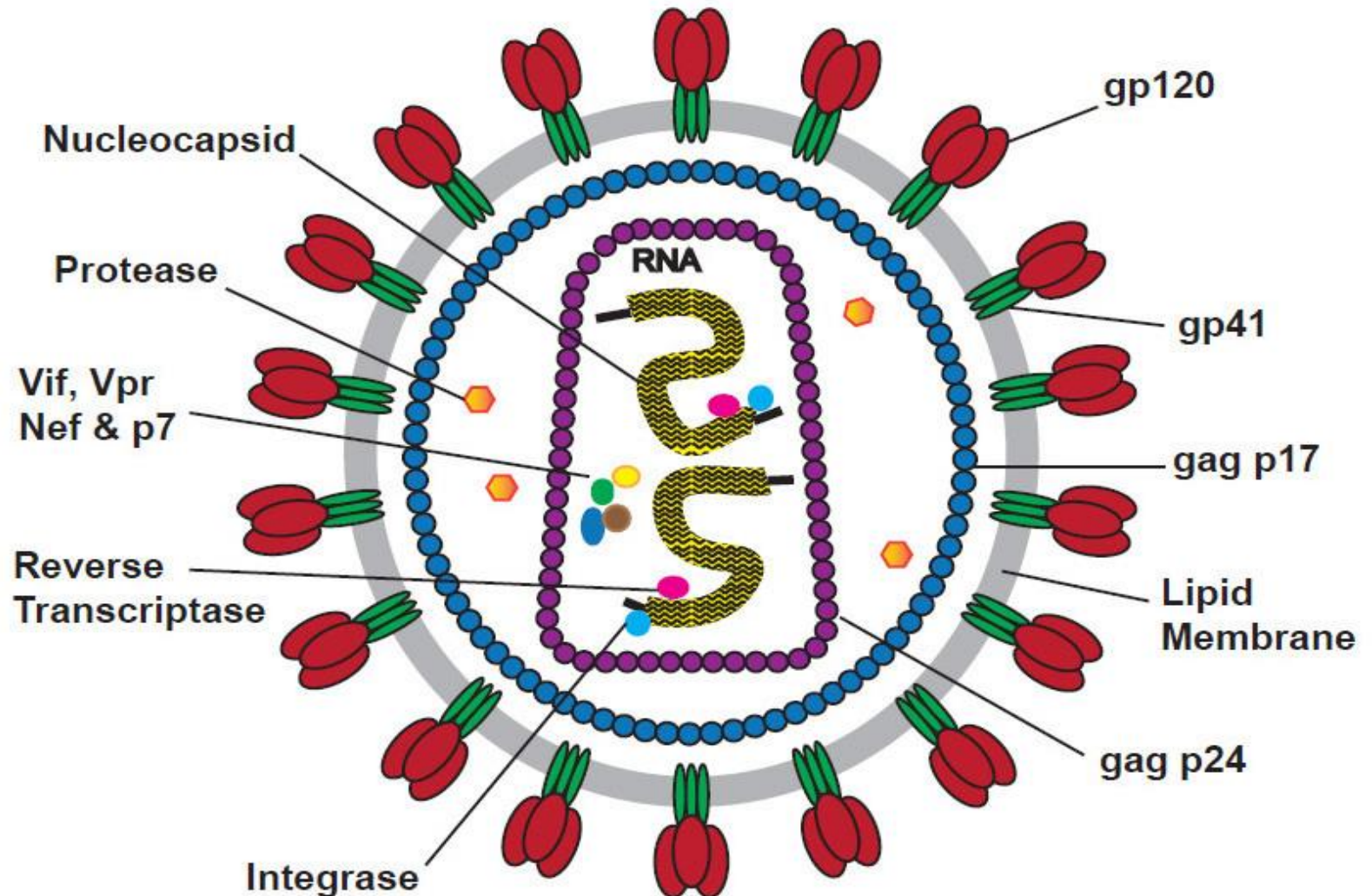

HIV Ligand-Cell Receptor interaction

- Ligand: HIV glycoprotein **gp120**
- Cellular Receptor: **CD4**
- Co-receptors: **CCR-5** or **CXCR4**
- HIV requires CD4 Receptor & a co-receptor for entry
- The receptors/co-receptors are expressed by immune cells (T-Cells and Antigen Presenting Cells)

HIV Co-receptors

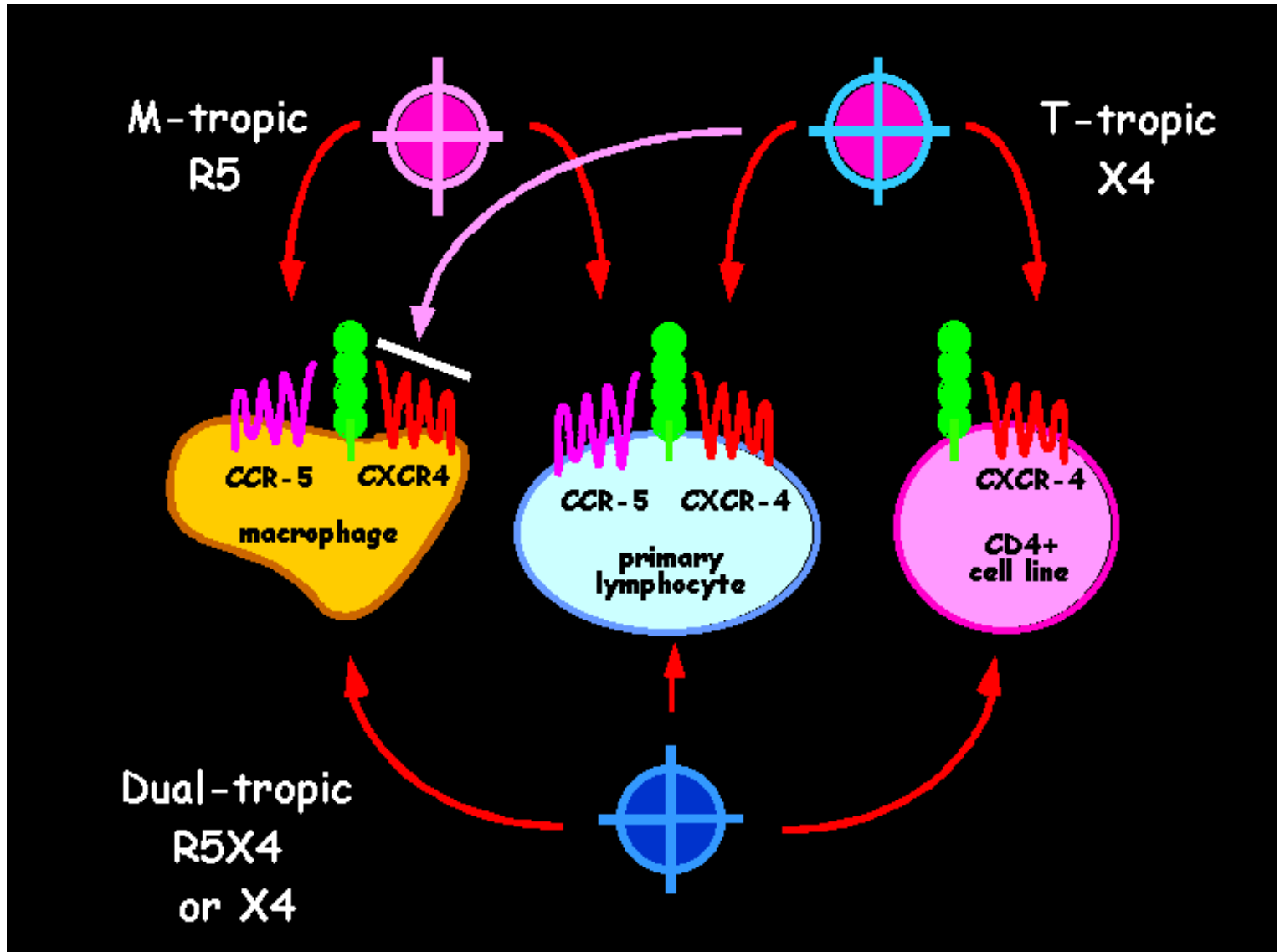

Retrovirus Replication Cycle

1. Entry
2. Reverse Transcription
3. Integration
4. Transcription
5. Translation
6. Maturation
7. Budding

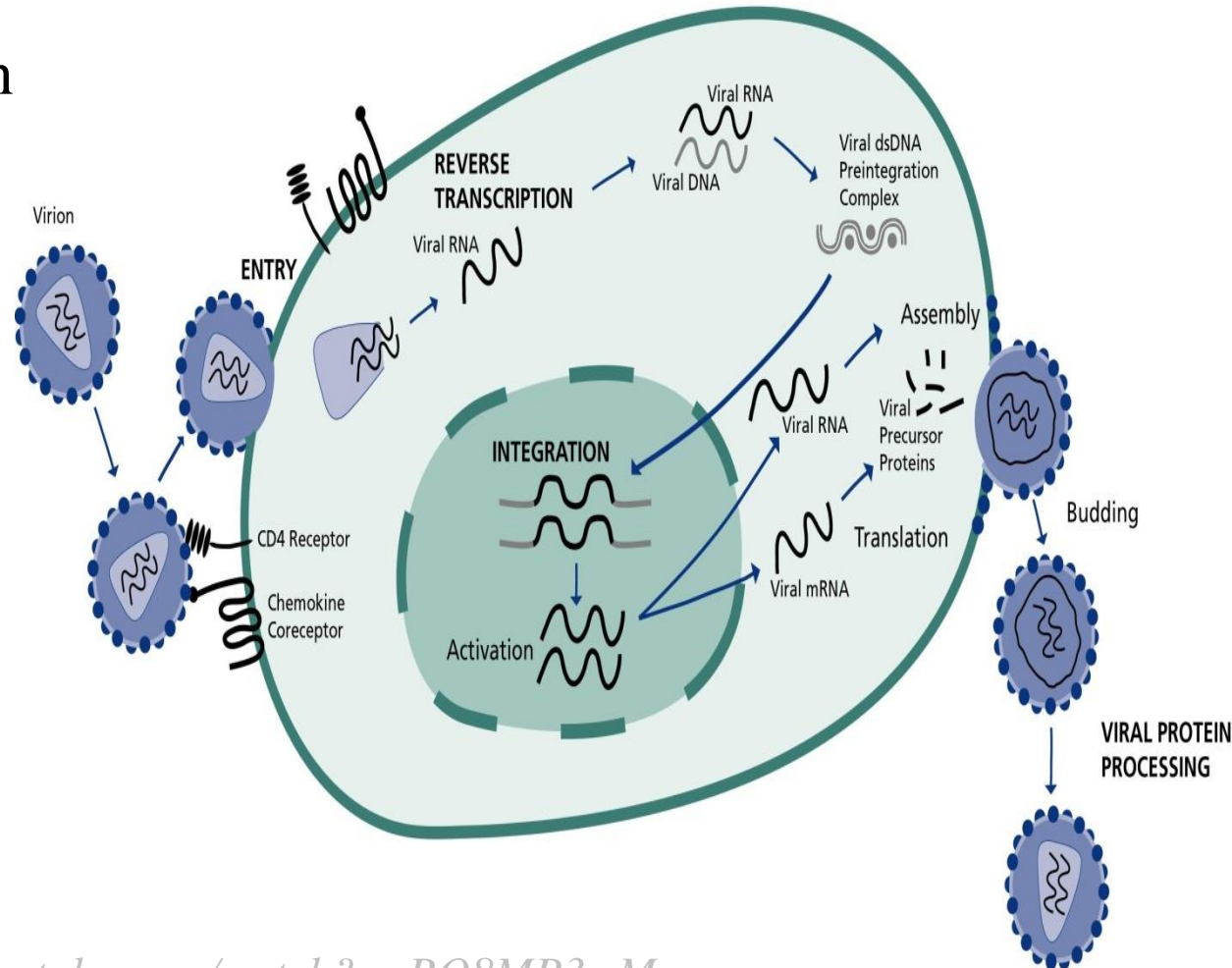

Transmission of HIV

- Sexual contact: oral, anal, vaginal
- Sharps – needles, blades
- Blood transfusion
- MTCT: during pregnancy, delivery, or breastfeeding



Risk factors: Acquisition of HIV Infection

- Nature of the exposure (the dose of HIV inoculum)
- HIV virus genetics
- Host susceptibility to infection (host genetics e.g. delta 32 mutation)
- Routes of transmission (intravenous > Rectal > Vaginal).
- Mucosal inflammation (ulceration by STDs)

Sequence of events in HIV infection

HIV infects CD4 cells (APC)



Disseminated infection



Specific immune Response (Ab, CMI)



Clearance of most virus



Some persistence

- a) Gradual loss of CD4 cells
- b) Destruction of lymphoid tissue

Clinical Features

1. **Primary stage/Acute retroviral syndrome**

- Seen in 10% of individuals a few weeks after exposure
- Acute seroconversion
- Presents with an ‘flu-like’ illness

2. **Asymptomatic stage**

- Months to >10 years
- Incubation period is 8-10 years
- May present with lymphadenopathy

3. **Symptomatic Stage**

- Opportunistic infections

4. **Full-blown AIDS**

- **AIDS** defining illnesses & cancers set in

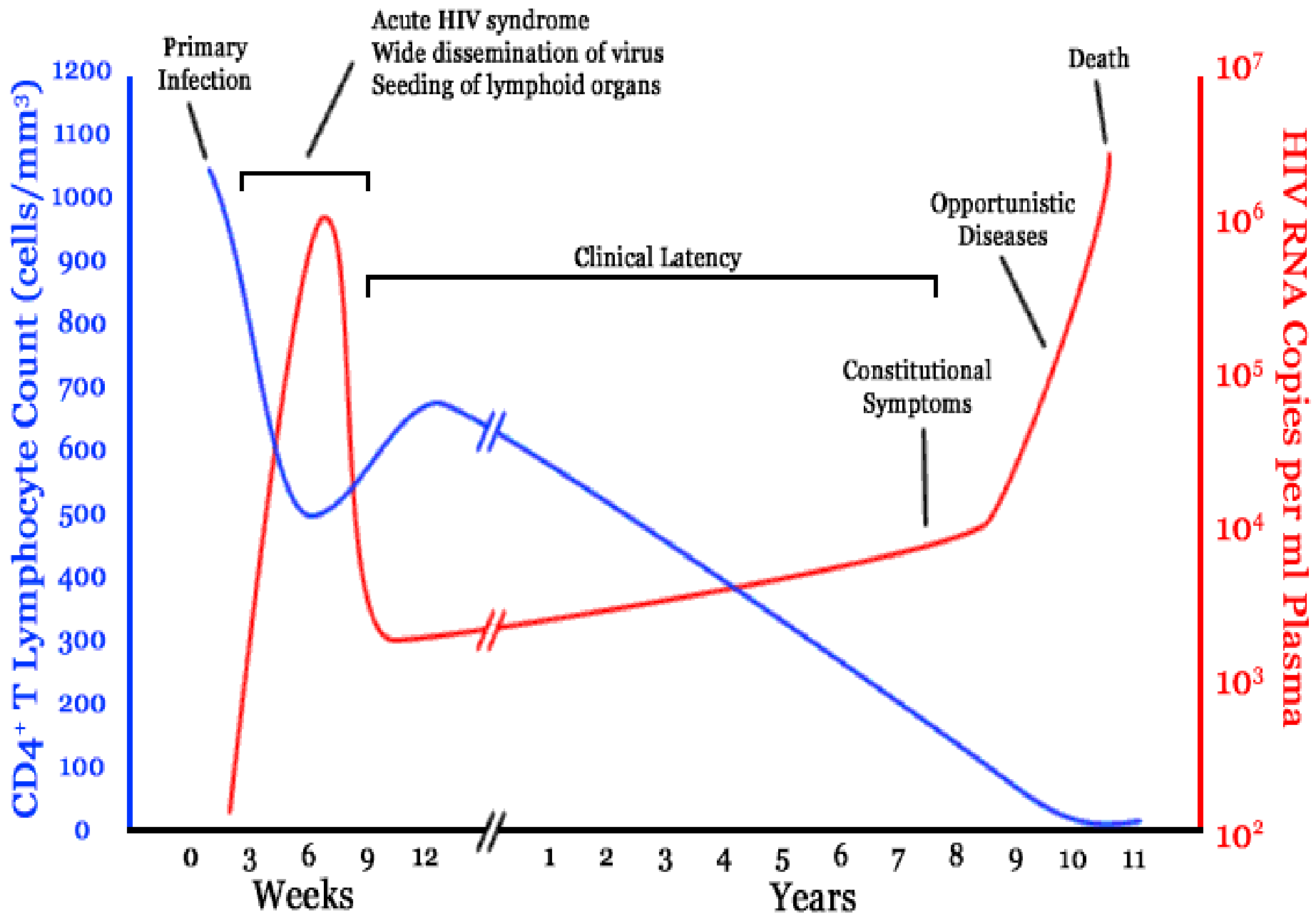

WHO HIV Staging

Stage	Clinical Condition	CD4 Count
	Primary HIV infection	
1	Asymptomatic	>500 cells/mm ³
2	Mild Symptoms	350-500 cells/mm ³
3	Symptomatic stage	200-350 cells/mm ³
4	AIDS	<200 cells/mm ³

Common OIs

STAGE	Opportunistic Infections
Primary Infection	Asymptomatic, Flu-like syndrome
I	Asymptomatic, Generalized Lymphadenopathy
II	Weight loss, Herpes zoster, Recurrent RTIs, PPE
III	Severe weight loss, Chronic diarrhea, Oral thrush, pTB , Severe bacteria infections
IV	Wasting, epTB, PCP, CNS toxoplasmosis, Cryptococcal meningitis, Esophageal candidiasis

Herpes zoster



Opportunistic Infections

Protozoal	PCP pneumonia, toxoplasmosis, cryptosporidiosis, Isosporiasis,
Fungal	Candidiasis, Cryptococcosis Histoplasmosis, Coccidioidomycosis
Bacterial	TB, MAC, Salmonella septicaemia Multiple or recurrent pyogenic bacterial infection (<i>meningitis, pneumonia, pyomyositis etc.</i>)
Viral	CMV, HSV, VZV, JCV

Opportunistic Infections/Cancers (by system)

Skin	Varicella zoster Herpes virus Kaposi sarcoma (associated with HHV-8)
Respiratory	PCP (<i>Pneumocystis jirovecci</i> pneumonia) Tuberculosis Severe Bacterial pneumonia Kaposi sarcoma
GIT	Cryptosporidiosis Candidiasis Isosporiasis Kaposi sarcoma Cytomegalovirus
CNS	Cytomegalovirus (CMV) infection Herpes simplex (HSV) encephalitis Toxoplasmosis Cryptococcosis Severe bacterial meningitis Non-Hodgkins Lymphoma (NHL)

Opportunistic Tumours

- Kaposi's sarcoma
- Lymphomas
- Cervical Cancer*

Kaposi's Sarcoma



Oral manifestations of HIV

- Candidiasis
- Hairy leukoplakia (EBV)
- Kaposi sarcoma (HHV-8)
- Herpes labialis
- Periodontitis
- Aphthous ulcers (cause unknown)
- Oral warts (HPV)
- Xerostomia



Kaposi sarcoma



Oral thrush



Hairy leukoplakia



Aphthous ulcers

Pyramid of Menkaure



HIV Testing

Purpose of HIV Testing

- Diagnosis
- Surveillance
- Medical legal.
- Blood and organ transfusion
- Travelling

HIV Tests

- Antibody Tests
- Antigen tests
- Nucleic acid tests

Serological Tests

1. Rapid HIV testing - Initial Screening
2. ELISA - Confirmation test
3. Western Blot Analysis - Confirmation Test
(rarely used nowadays)
4. p24 antigen - Detection of a recent infection

HIV Antibody Rapid Test

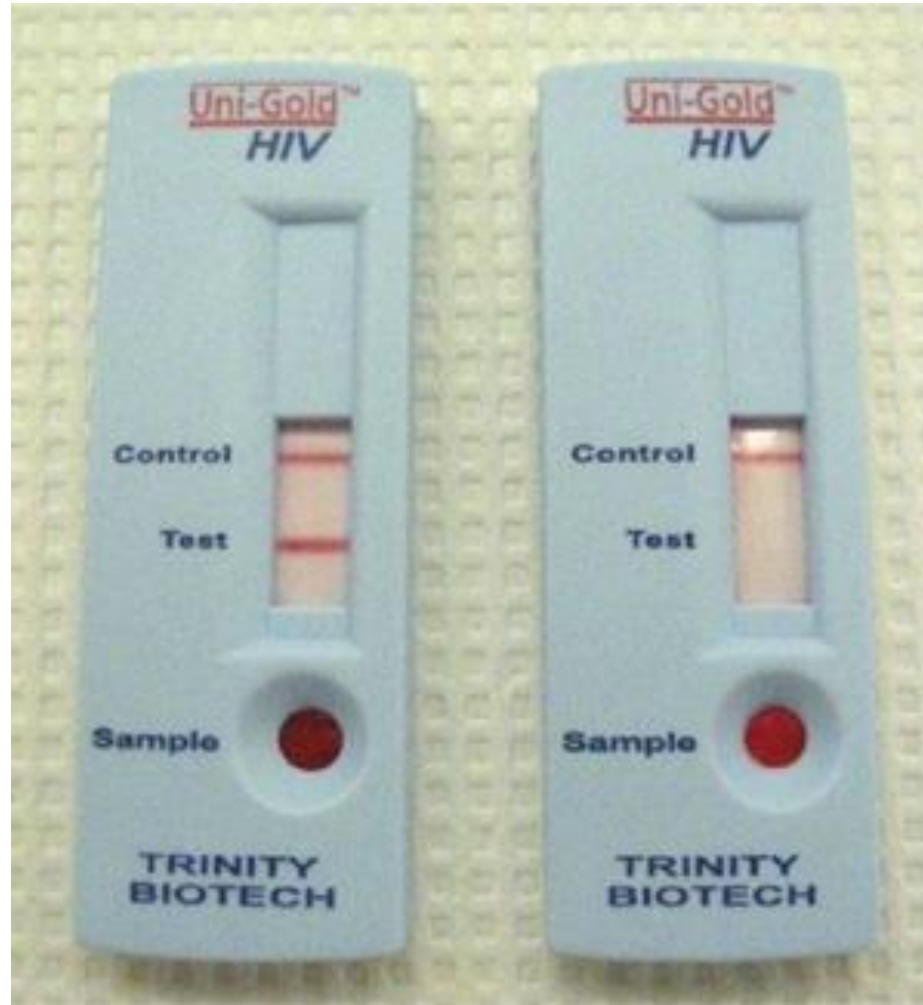

ELISA for HIV antibody



Nucleic Acid Detection

- Detection of HIV viral genome through **PCR**
 - HIV DNA PCR Can be:
 1. Qualitative – HIV PCR to detect presence of infection
 2. Quantitative – HIV PCR to measure viral load
- HIV DNA PCR is appropriate for infants < 18 months

Baseline Investigations for HIV Positive Individuals

Investigation		Purpose
Immunology	CD4, CD8	<i>Prognostic indicator Initiation of ART/Prophylaxis</i>
HIV Virology	Antibody test (ELISA) Plasma viral load Resistance testing	<i>Confirmation of infection Prognostic indicator Guide choice of ART</i>
Microbiology	Syphilis Toxoplasmosis Hepatitis B & C	<i>Detect latent disease Previous exposure, risk of recurrence Guide ART choice & initiation</i>
Biochemistry	Renal Function Tests Liver Function Tests FBS, Lipid Profile	<i>Baseline, Guide ART Subclinical disease, Baseline, Guide choice of ART Baseline, Guide ART</i>
Hematology	Full Blood Count G6PD Deficiency	<i>Detect hematologic abnormalities, Guide choice of ART Guide ART and prophylaxis for Opportunistic infections</i>
Radiology	Chest X-ray Chest CT scan	<i>Detect latent TB infection</i>

Antiretrovirals - Drug targets

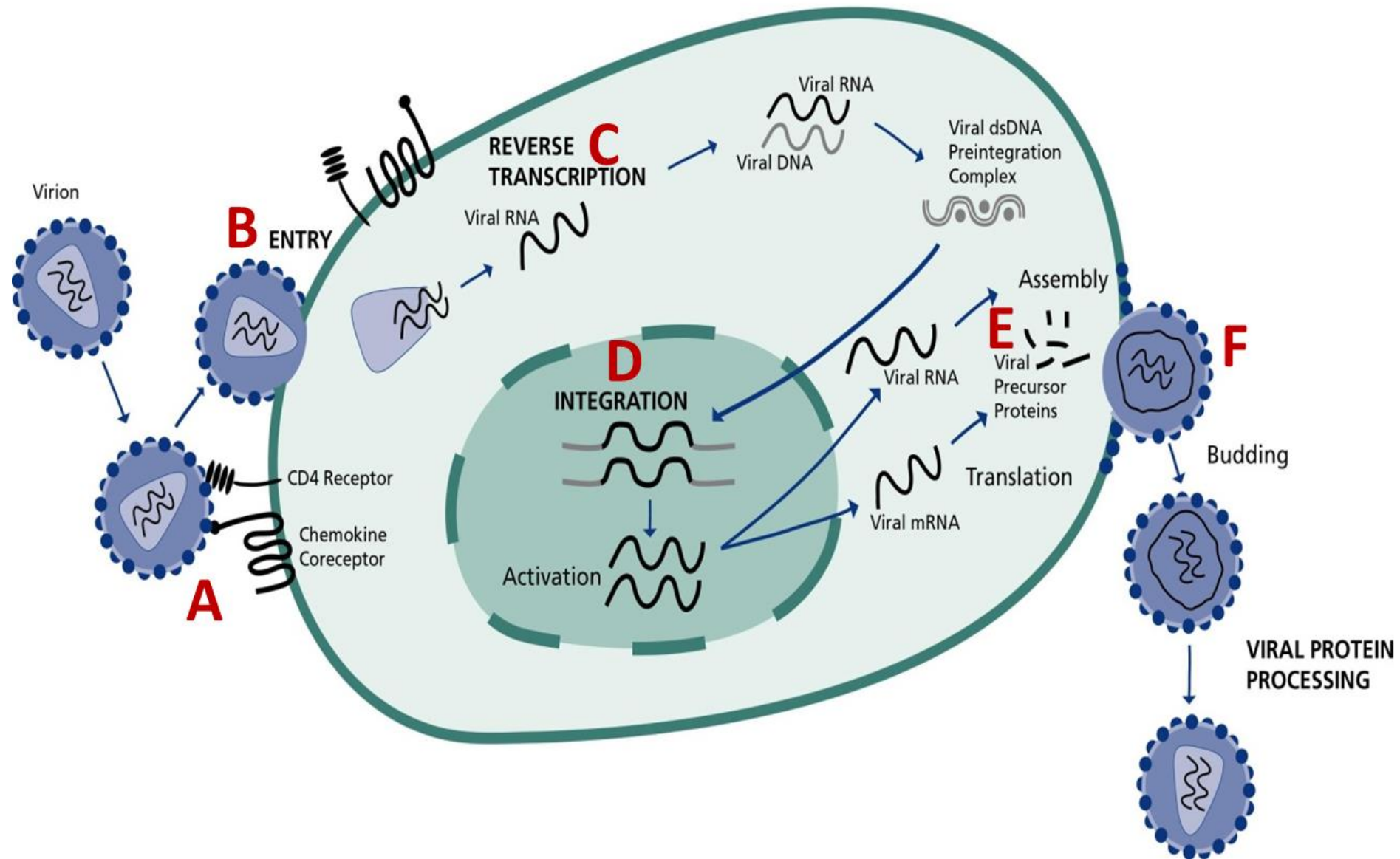

Classes of ARVs

1. Nucleoside Reverse Transcriptase Inhibitors (NRTIs):

Zidovudine, Lamivudine, Abacavir, Tenofovir*

2. Non-Nucleoside RT Inhibitors

Nevirapine, Efavirenz, Etravirine, Delavirdine

3. Protease Inhibitors

Lopinavir, Ritonavir, Atazanavir, etc.

4. Integrase Inhibitors

Raltegravir, Dolutegravir, Elvitegravir

5. Attachment inhibitor: Maraviroc

6. Fusion Inhibitor: Enfuvirtide

1. Reverse Transcriptase Inhibitors

Block DNA synthesis from RNA by *Reverse transcriptase* aka *RNA-dependent DNA polymerase*

i. Nucleoside & Nucleotide Reverse Transcriptase Inhibitors (NRTIs):

Zidovudine, Lamivudine, Abacavir, Tenofovir

ii. Non-Nucleoside RT Inhibitors

Nevirapine, Efavirenz, Etravirine

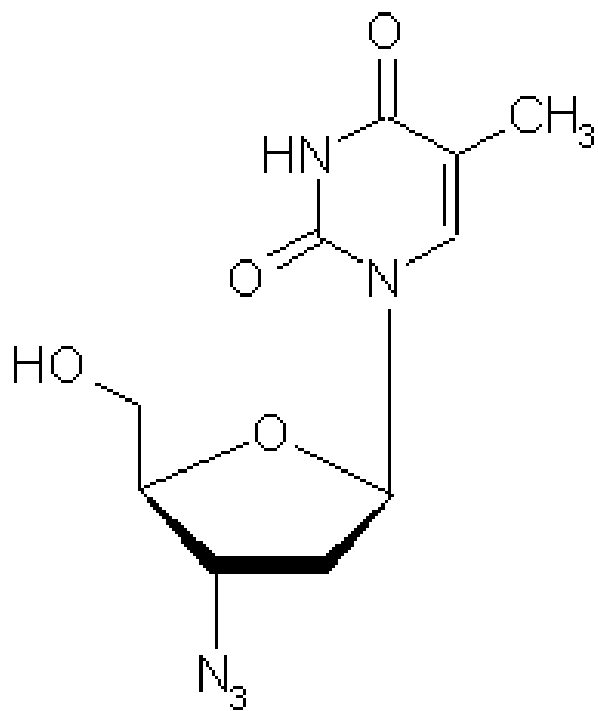

Zidovudine

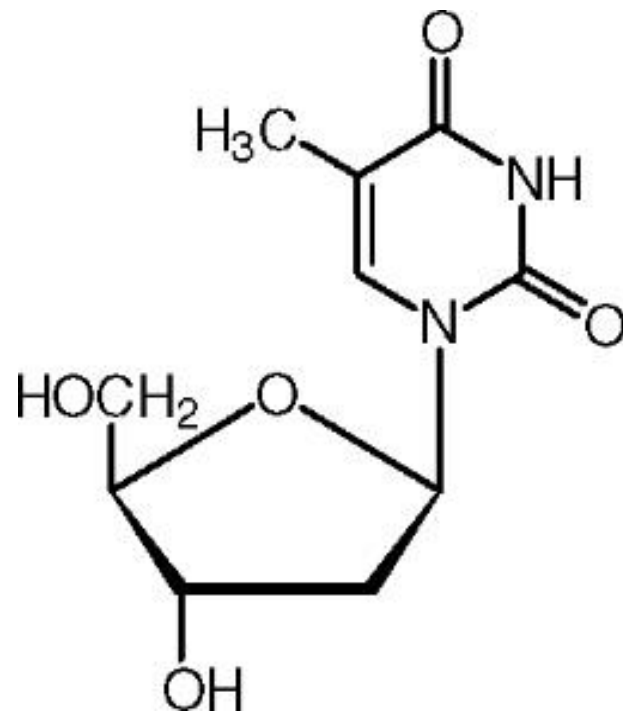

Thymidine

2. Protease Inhibitors

Bind *Protease* preventing protein cleavage hence blocking viral maturation

- **Ritonavir**
- **Lopinavir**
- Atazanavir
- Darunavir

ART...

3. **Integrase inhibitors**

- Bind integrase preventing integration of HIV into host DNA
- e.g. *Raltegravir, Dolutegravir*

4. **Fusion inhibitors**

- Interfere with binding & fusion of HIV with cell membrane
- e.g. *Enfuvirtide*

5. **CCR5 antagonists** (against R5-tropic viruses)

- Bind CCR5 co-receptor preventing attachment
- e.g. *Maraviroc*

Prevention Targets

- **GLOBAL:** 90-90-90 by 2020
- **NATIONAL:** Zero New Infections by 2030;
 - 75% reduction of new infections by 2020
- **WHO:** Universal Testing & Treatment (UTT)
- **ULTIMATE:** Eradicate HIV

Control & Prevention

- Safer Sex practices
- Screening (blood & blood products, organ donors)
- Prevention of Mother to Child Transmission (MTCT)
- Early testing and linkage with care
- Treatment for prevention
- Voluntary Male Medical Circumcision (VMMC)
- Post-exposure prophylaxis (PEP)
- Pre-exposure prophylaxis (PreP)
- ?? *Vaccines (Research in progress)*

The Berlin Patient



‘I once had HIV!’

Functional cure for HIV

- March 2013: "*functional cure*" in a *HIV*-positive girl (*Mississippi baby*)
- ART started 30hrs after birth
- Two years later, that HIV not present in her blood.
- **Now back on ART after traces of HIV genome were detected**

References

1. Jawetz, Melnick & Adelbergs Medical Microbiology 26E, McGraw-Hill, LANGE – Brooks, Carroll & Butel
2. Virology: Principles & Applications, John Wiley & Sons Ltd – Carter & Saunders
3. www.microbiologybook.org
4. PUBMED: <https://www.ncbi.nlm.nih.gov/pubmed/>
5. Google Scholar: www.scholar.google.com

QUESTIONS?



@mosmasika

@MicrobiologyUoN



mosmasika@gmail.com



Masika Moses

Medical Microbiology UoN